

# Atomx XYZ User Manual

Part Number: 15-3200-074

Rev: A, Nov - 2017



All rights reserved. Reproduction, adaptation, or translation without permission is prohibited, except as allowed under copyright laws. Printed in the U.S.A.

## Updated Information

The information contained in this document is subject to change without notice.

## Trademarks

**The companies indicated own the following trademarks:**

Tekmar ..... Teledyne Instruments, Inc.

All other brands or product names are trademarks or registered trademarks of their respective owners.

Teledyne Tekmar  
4736 Socialville Foster Road  
Mason, OH 45040 U.S.A  
[www.teledynetekmar.com](http://www.teledynetekmar.com)

**Toll Free:** 800-543-4461  
**Sales/Support:** 800-874-2004  
**Main:** 513-229-7000  
**Fax:** 513-229-7050





# Atomx XYZ User Manual

## Table of Contents

### Preface

P.1 Warranty	P-1
P.2 Teledyne Tekmar Customer Support Center	P-1
P.3 Essential Instructions	P-1
P.4 Notations and Hazard Severity Levels	P-2
P.5 Atomx XYZ Safety Symbols Defined	P-3
P.6 Atomx XYZ Safety Labels	P-5
P.7 Working Safely	P-6
P.8 Explanation of Regulatory Marks	P-9
P.8.1 Unit Disposal	P-9
P.8.2 CE Mark	P-9

### Chapter 1: Introduction

1.1 Atomx XYZ with Methanol Extractions Overview	1-1
1.2 Purge and Trap Background	1-1
1.2.1 Purge and Trap Fundamentals	1-1
1.2.2 Brief History	1-2
1.3 Purge and Trap Operation Overview	1-2
1.3.1 Trapping, Adsorption and Desorption	1-4
1.4 Atomx XYZ Specifications	1-5
1.5 Atomx XYZ Component Overview	1-11
1.5.1 Sample Mount and Sparger	1-13
1.5.2 Vials	1-13
1.5.3 Internal Standard Pressure Regulator	1-14
1.5.4 Internal Standard Vessels	1-14
1.5.5 Syringe Drive with Sweepable 25 mL Syringe	1-15
1.5.6 Sample Needle	1-15
1.5.7 XYZ Autosampler Pick and Place Assembly	1-16
1.5.8 Elevator	1-16
1.5.9 Vial Mixer Assembly	1-17
1.5.10 Status Light	1-17
1.5.11 Sample Purge Gas Inlet	1-18
1.5.12 Mass Flow Controller (MFC)	1-18
1.5.13 Sample Pathway	1-18
1.5.14 Analytical Trap	1-19
1.5.15 Moisture Control System (MCS)	1-19
1.5.16 Carrier Gas Inlet Line/Heated Sample Transfer Line	1-20
1.5.17 Valving	1-21
1.6 Optional Accessories	1-23
1.6.1 Sparge Vessel Heater	1-23
1.6.2 Vial Chiller Plate	1-24
1.6.3 Guardian Foam Sensor and Eliminator	1-24

### Chapter 2: Installation and Setup

2.1 Pre-Installation	2-1
2.1.1 Overview	2-1
2.1.2 Operating Environment	2-1
2.1.3 Work Surface Requirements	2-2
2.1.4 Electrical Requirements	2-2

2.1.5	Gas Supply Requirements	2-3
2.1.6	Minimum Computer Requirements	2-4
2.2	Required Tools and Supplies for Installation and Operation	2-4
2.3	Unpacking the Atomx XYZ	2-5
2.4	Installation Kit Box	2-5
2.5	Atomx XYZ System Overview	2-6
2.6	Electrical and Data Connections	2-8
2.6.1	AC Power Cord	2-8
2.6.2	GC I/O (Input/Output) Connection	2-9
2.7	Gas Connections	2-10
2.7.1	Connecting the Atomx XYZ Sample Purge Gas Supply	2-10
2.7.2	Atomx XYZ Carrier Gas Supply and Heated Sample Transfer Line Connection to the Gas Chromatograph (GC)	2-11
2.8	Liquid Connections	2-13
2.8.1	Drain Tubing	2-13
2.8.2	DI Water Reservoir Connection	2-13
2.8.3	Optional Methanol Reservoir Connection	2-14
2.8.4	Optional Vial Chiller Plate Tubing Connections	2-15
2.9	Install Atomx XYZ TekLink Software	2-16
2.9.1	Connect the USB Interface Cable	2-22
2.10	Create an Instrument Profile	2-22
2.11	Guardian Foam Sensor and Foam Eliminator (Optional)	2-25
2.11.1	Atomx XYZ with Guardian Foam Sensor	2-26
2.11.2	Atomx XYZ with Guardian Foam Sensor and Foam Eliminator	2-26
2.11.3	Configuring the Guardian Foam Sensor & Eliminator	2-26
2.12	Preparing DI Water	2-27
2.13	Methanol Supply Grade	2-27
2.14	Preparing Working Standards	2-28
2.14.1	Working Standard Sample Calculation	2-28

### Chapter 3: Atomx XYZ TekLink Software Overview

3.1	About Atomx XYZ TekLink Software	3-1
3.2	The Atomx XYZ TekLink Software Environment	3-1
3.2.1	Touchscreen Capability	3-1
3.2.2	“Pinnable” Screens	3-2
3.2.3	Title Bar	3-2
3.2.4	Open, Save, Load, and Print Buttons	3-3
3.2.5	Instrument Control Buttons	3-3
3.2.6	Delete at Next Archive Check-Box	3-4
3.3	Primary Screens	3-5
3.3.1	The Home Screen	3-5
3.3.2	Instrument Status Panel	3-6
3.4	Methods Screen	3-7
3.4.1	Standby Tab	3-7
3.4.2	Purge Tab	3-8
3.4.3	Desorb Tab	3-12
3.4.4	Bake Tab	3-13
3.5	Schedules Screen	3-14
3.6	Tools Screen	3-16
3.6.1	Prime Menu	3-17
3.6.2	Commands Menu	3-17
3.6.3	System Menu	3-20
3.6.4	Diagnostics	3-28
3.7	Add, Connect and Deactivate an Instrument Profile	3-32
3.7.1	Add an Instrument Profile and Connect	3-32

3.7.2 Deactivate an Instrument Profile . . . . .	3-34
3.8 Using the Methods Screen . . . . .	3-35
3.8.1 Methods Types . . . . .	3-35
3.8.2 Default Methods . . . . .	3-35
3.8.3 Open a Method . . . . .	3-36
3.8.4 Creating a Custom Method . . . . .	3-36
3.8.5 Load the Method . . . . .	3-39
3.8.6 Print a Method . . . . .	3-39
3.9 Using the Schedule Screen . . . . .	3-39
3.9.1 Open Schedule . . . . .	3-39
3.9.2 Create a Schedule . . . . .	3-39
3.9.3 Save Schedule . . . . .	3-42
3.9.4 Print Schedule . . . . .	3-43
3.9.5 Load (Run) the Schedule . . . . .	3-43
3.9.6 Step Schedule . . . . .	3-44
3.9.7 Hold Schedule . . . . .	3-44
3.9.8 Abort a Sample or Schedule . . . . .	3-45
3.9.9 Completion of the Schedule . . . . .	3-45
3.10 Data Storage Location and Archiving Data . . . . .	3-46

## Chapter 4: Instrument Operations

4.1 Atomx XYZ Mode Descriptions . . . . .	4-1
4.2 Atomx XYZ Valve Output/Mechanism Chart . . . . .	4-3
4.2.1 Waters . . . . .	4-3
4.2.2 Soils . . . . .	4-5
4.2.3 Methanol Extraction . . . . .	4-6
4.3 Optimization/Method Development . . . . .	4-8
4.3.1 Purge Mode . . . . .	4-10
4.3.2 Dry Purge Mode . . . . .	4-10
4.3.3 Desorb Ready Mode . . . . .	4-10
4.3.4 Desorb Pre-Heat Mode . . . . .	4-10
4.3.5 Desorb Mode . . . . .	4-11
4.3.6 Bake Mode . . . . .	4-11
4.4 Method Parameters . . . . .	4-12
4.4.1 Water . . . . .	4-12
4.4.2 Soil . . . . .	4-13
4.4.3 Methanol Extraction . . . . .	4-14
4.5 Analytical Trap Recommended Operating Conditions . . . . .	4-15

## Chapter 5: Maintenance and Troubleshooting

5.1 Replacing Parts . . . . .	5-1
5.2 Preventative Maintenance Checks . . . . .	5-2
5.2.1 Daily Maintenance Checks . . . . .	5-2
5.2.2 Weekly Maintenance Checks . . . . .	5-2
5.2.3 Monthly Maintenance Checks . . . . .	5-3
5.2.4 Quarterly Maintenance Checks . . . . .	5-3
5.3 Preventative Maintenance Chart . . . . .	5-4
5.4 GC In/Out (I/O) Cable and GC Type Reference . . . . .	5-5
5.5 Instrument Access Panels . . . . .	5-6
5.6 Plumbing Overview . . . . .	5-8
5.7 Electrical Overview . . . . .	5-10
5.7.1 Printed Circuit Boards . . . . .	5-10
5.7.2 CPU Communication Board (Master Board) . . . . .	5-12
5.7.3 Multi-Channel Temperature Control Board . . . . .	5-13
5.7.4 DC Valve Control Board . . . . .	5-14
5.7.5 Internal Standard Valve Control Board . . . . .	5-15

5.7.6	Banner Board/Status Light . . . . .	5-16
5.7.7	XYZ Interface Board . . . . .	5-16
5.7.8	XYZ Control Board . . . . .	5-17
5.7.9	XYZ Input/Output Board . . . . .	5-17
5.7.10	Elevator Drive Board . . . . .	5-18
5.7.11	Power Supplies . . . . .	5-18
5.8	System Leak Check . . . . .	5-19
5.8.1	System Leak Check Flow Diagram . . . . .	5-20
5.8.2	Leak Check Failed - Check Subsystem A . . . . .	5-21
5.8.3	Subsystem A Leak Check Flow Diagram . . . . .	5-22
5.8.4	Leak Check Failed - Check Subsystem B . . . . .	5-23
5.8.5	Subsystem B Leak Check Flow Diagram . . . . .	5-24
5.8.6	Leak Check Failed - Check Subsystem C . . . . .	5-25
5.8.7	Subsystem C Leak Check Flow Diagram . . . . .	5-26
5.8.8	Leak Check Failed - All Subsystems Checked and Passed . . . . .	5-27
5.9	Glassware Good Practices Cleaning Procedures . . . . .	5-27
5.9.1	Sparger Cleaning . . . . .	5-27
5.10	Verifying/Setting Internal Standard Vessel Pressure . . . . .	5-28
5.10.1	Verify the Internal Standard Vessel Pressure . . . . .	5-28
5.10.2	Setting the Internal Standard Vessel Pressure . . . . .	5-29
5.11	Sample Needle Replacement . . . . .	5-30
5.11.1	Tools and Supplies . . . . .	5-30
5.11.2	Procedure . . . . .	5-30
5.12	Sparger Replacement . . . . .	5-32
5.13	Analytical Trap Replacement . . . . .	5-34
5.14	Analytical Trap Conditioning . . . . .	5-36
5.14.1	Analytical Trap Recommended Conditioning Settings . . . . .	5-36
5.14.2	Procedure . . . . .	5-36
5.15	Elevator Lubrication . . . . .	5-37
5.15.1	Tools and Supplies . . . . .	5-37
5.15.2	Procedure . . . . .	5-37
5.16	XYZ Autosampler Alignment . . . . .	5-38
5.16.1	When is Alignment Needed? . . . . .	5-39
5.16.2	Alignment Overview . . . . .	5-39
5.16.3	Tools and Supplies . . . . .	5-40
5.16.4	Procedure . . . . .	5-40
5.17	Syringe Initialization . . . . .	5-52
5.18	Syringe Replacement . . . . .	5-52
5.19	Power Entry Module (PEM) Fuse Replacement . . . . .	5-52
5.20	Multi-Channel Temperature Control Board Fuse Replacement . . . . .	5-55
5.20.1	Main Fuse . . . . .	5-55
5.20.2	Heater Output Fuses . . . . .	5-57
5.21	Upgrade Firmware . . . . .	5-59
5.21.1	Download Firmware . . . . .	5-59
5.21.2	Upgrade Board Firmware . . . . .	5-60
5.22	Upgrade Atomx XYZ TekLink Software . . . . .	5-60
5.23	Troubleshooting . . . . .	5-60
5.23.1	Benchmark Test . . . . .	5-60
5.23.2	No Power Flow Chart . . . . .	5-62
5.23.3	No Response Flow Chart . . . . .	5-63
5.23.4	Low Response Flow Chart . . . . .	5-64
5.23.5	Carryover Contamination Flow Chart . . . . .	5-65
5.24	Returning the Atomx XYZ . . . . .	5-66
5.24.1	Prepare for Shipment Function . . . . .	5-66
5.25	Unit and Parts Disposal . . . . .	5-66

5.26 Technical Assistance . . . . .	5-66
5.26.1 Teledyne Tekmar Customer Support . . . . .	5-66

## Appendix A: Diagrams

A.1 Atomx XYZ Concentrator Electrical Schematic . . . . .	A-1
A.2 Atomx XYZ Autosampler Electrical Schematic . . . . .	A-2
A.3 Atomx XYZ Plumbing Diagram . . . . .	A-3
A.4 Atomx XYZ Flow Diagrams . . . . .	A-5
A.4.1 Atomx XYZ - Basic Flow Diagram . . . . .	A-5
A.4.2 Atomx XYZ - Waters Flow Diagram - Standby Purge Ready . . . . .	A-6
A.4.3 Atomx XYZ - Waters Flow Diagram - Sample Fill . . . . .	A-7
A.4.4 Atomx XYZ Waters Flow Diagram - Sample Transfer . . . . .	A-8
A.4.5 Atomx XYZ Waters Flow Diagram - Purge . . . . .	A-9
A.4.6 Atomx XYZ Waters Flow Diagram - Dry Purge . . . . .	A-10
A.4.7 Atomx XYZ Waters Flow Diagram - Desorb . . . . .	A-11
A.4.8 Atomx XYZ Waters Flow Diagram - Bake Rinse Fill . . . . .	A-12
A.4.9 Atomx XYZ Waters Flow Diagram - Bake Rinse Transfer . . . . .	A-13
A.4.10 Atomx XYZ Waters Flow Diagram - Bake Rinse Drain . . . . .	A-14
A.4.11 Atomx XYZ Waters Flow Diagram - Bake . . . . .	A-15
A.4.12 Atomx XYZ Soils Flow Diagram - Standby/Purge Ready . . . . .	A-16
A.4.13 Atomx XYZ Soils Flow Diagram - DI Transfer to Vial . . . . .	A-17
A.4.14 Atomx XYZ Soils Flow Diagram - Purge . . . . .	A-18
A.4.15 Atomx XYZ Soils Flow Diagram - Dry Purge . . . . .	A-19
A.4.16 Atomx XYZ Soils Flow Diagram - Bake . . . . .	A-20
A.4.17 Atomx XYZ Methanol Flow Diagram - Fill . . . . .	A-21
A.4.18 Atomx XYZ Methanol Flow Diagram - Dispense to Vial . . . . .	A-22
A.4.19 Atomx XYZ Methanol Flow Diagram - Extract Fill . . . . .	A-23
A.4.20 Atomx XYZ Methanol Flow Diagram - Dispense Extract to Glassware . . . . .	A-24
A.4.21 Atomx XYZ - Eliminator Flow Diagram - Basic . . . . .	A-25
A.4.22 Atomx XYZ - Eliminator - Ready . . . . .	A-26
A.4.23 Atomx XYZ - Eliminator Flow Diagram - Add Defoamer . . . . .	A-27
A.4.24 Atomx XYZ - Eliminator Flow Diagram - Rinse . . . . .	A-28

## List of Figures

1-1 Headspace Equilibrium Diagram . . . . .	1-3
1-2 Sample Mount and Sparger . . . . .	1-13
1-3 Maximum Vial Dimensions . . . . .	1-14
1-4 Internal Standard Vessels . . . . .	1-14
1-5 Syringe . . . . .	1-15
1-6 Sample Needle . . . . .	1-15
1-7 Elevator and Sample Vial Cup . . . . .	1-16
1-8 Vial Mixer . . . . .	1-17
1-9 Unit Status Light . . . . .	1-17
1-10 Mass Flow Controller . . . . .	1-18
1-11 Atomx XYZ Analytical Trap Compartment . . . . .	1-19
1-12 Moisture Control System . . . . .	1-20
1-13 Carrier Gas Inlet Line and Heated Sample Transfer Line . . . . .	1-20
1-14 Atomx XYZ Valve Manifold (Valves Mounted Underneath) . . . . .	1-21
1-15 Heated 6-Port Valve . . . . .	1-22
1-16 Soil Valve . . . . .	1-22
1-17 6-Port Syringe Valve . . . . .	1-23
1-18 Sparge Vessel Heater . . . . .	1-23
1-19 Vial Chiller Plate . . . . .	1-24

1-20 Guardian Foam Sensor and Foam Eliminator/Rinse Vessels . . . . .	1-24
2-1 Installation Kit Box Label . . . . .	2-5
2-2 Front of Atomx XYZ . . . . .	2-6
2-3 Back of Atomx XYZ . . . . .	2-7
2-4 Atomx XYZ Power Entry Module . . . . .	2-8
2-5 GC I/O Cable Connection. . . . .	2-9
2-6 Sample Purge Gas Tubing. . . . .	2-10
2-7 Atomx XYZ Carrier Gas Line /Heated Sample Transfer Line. . . . .	2-11
2-8 Atomx Carrier Gas Line, Heated Sample Transfer Line and Purge Gas Tubing Connections 2-11	
2-9 Drain Tubing. . . . .	2-13
2-10 DI Water Tubing (Weights Not Shown) . . . . .	2-14
2-11 Methanol Supply Tubing. . . . .	2-15
2-12 Recirculating Bath Connection to Vial Chiller Tray. . . . .	2-15
2-13 Atomx XYZ Software Install Menu . . . . .	2-16
2-14 Atomx XYZ TekLink Installation Wizard . . . . .	2-16
2-15 Release Notes . . . . .	2-17
2-16 License Agreement. . . . .	2-17
2-17 Select Destination Location . . . . .	2-18
2-18 Select Components . . . . .	2-18
2-19 Select the Start Menu Folder . . . . .	2-19
2-20 Select Additional Tasks . . . . .	2-19
2-21 Ready to Install. . . . .	2-20
2-22 Installation in Progress. . . . .	2-20
2-23 Windows Security Prompt . . . . .	2-21
2-24 Software Completion . . . . .	2-21
2-25 Atomx XYZ USB Connection . . . . .	2-22
2-26 Creating an Instrument Profile . . . . .	2-23
2-27 Options Tab . . . . .	2-24
2-28 Leak Check Tab . . . . .	2-24
2-29 Instrument Manager Showing Instrument Connected and Default Profile . . . . .	2-25
2-30 Configuration Dialog- Guardian Foam Sensor . . . . .	2-27
3-1 On-Screen Keyboard . . . . .	3-1
3-2 Pin Function . . . . .	3-2
3-3 Schedules Screen Title Bar . . . . .	3-2
3-4 Open, Save, Load, and Print Buttons. . . . .	3-3
3-5 Control Buttons. . . . .	3-3
3-6 Delete at Next Archive Check-Box - Schedule Screen. . . . .	3-4
3-7 Open Schedule Dialog Source Drop-down Menu. . . . .	3-4
3-8 Home Screen . . . . .	3-5
3-9 Instrument Status Panel. . . . .	3-6
3-10 Instrument Status Zone Display Options . . . . .	3-6
3-11 Choose Method Type Dialog . . . . .	3-7
3-12 Methods Screen Water, Soil, and Methanol Extraction Headers . . . . .	3-7
3-13 Water Methods Screen - Standby Tab . . . . .	3-8
3-14 Waters Methods Screen - Purge Tab - Sparge Vessel Heater Enabled . . . . .	3-9
3-15 Soil Methods Screen - Purge Tab . . . . .	3-10
3-16 Methanol Extraction Methods Screen - Purge Tab. . . . .	3-11
3-17 Waters Methods Screen - Desorb Tab. . . . .	3-12
3-18 Water Methods Screen - Bake Tab . . . . .	3-13
3-19 Methanol Methods Screen - Bake Tab. . . . .	3-14
3-20 Schedules Screen - Foam Column Not Enabled . . . . .	3-16
3-21 Tools Screen . . . . .	3-16
3-22 Instrument Status Showing Leak Check Mode. . . . .	3-18

3-23	Bake Dialog . . . . .	3-19
3-24	Tools - Configuration - General Tab . . . . .	3-20
3-25	Tools - Configuration - Options Tab . . . . .	3-21
3-26	Tools - Configuration - Leak Check Tab . . . . .	3-22
3-27	Tools - Instrument Manager . . . . .	3-23
3-28	System Properties Dialog . . . . .	3-23
3-29	System Properties - Data Tab . . . . .	3-24
3-30	Figure 3-30 System Properties - Misc Tab . . . . .	3-25
3-31	History Log - Sample History . . . . .	3-25
3-32	History Log - Instrument History . . . . .	3-26
3-33	History Log Event Filter . . . . .	3-26
3-34	About Dialog . . . . .	3-27
3-35	Diagnostics - Valves and Flows . . . . .	3-28
3-36	Vials/Elevator . . . . .	3-29
3-37	Pumper Diagnostics . . . . .	3-30
3-38	Upgrade Firmware Dialog . . . . .	3-31
3-39	Benchmark Test . . . . .	3-31
3-40	Creating an Instrument Profile . . . . .	3-33
3-41	Options Tab . . . . .	3-33
3-42	Leak Check Tab . . . . .	3-34
3-43	Configuration Dialog Showing Current Instrument Profile . . . . .	3-35
3-44	Choose Method Type . . . . .	3-36
3-45	Methods Screen Water, Soil, and Methanol Extraction Headers . . . . .	3-37
3-46	Waters Methods Screen - Water Method . . . . .	3-37
3-47	Save Method As Dialog . . . . .	3-38
3-48	New Method Saved - Name in Title Bar . . . . .	3-38
3-49	Schedules Screen - Blank Schedule . . . . .	3-39
3-50	Schedules Screen Right-Click Options . . . . .	3-40
3-51	Zero in Vial Column Becomes Blank . . . . .	3-41
3-52	Select Method Dialog . . . . .	3-41
3-53	Sample ID Column . . . . .	3-41
3-54	Select Standard Drop-Down . . . . .	3-42
3-55	Save Schedule . . . . .	3-42
3-56	Schedule Loaded . . . . .	3-43
3-57	Instrument Status Panel Updated . . . . .	3-44
3-58	Schedule Hold - Instrument Status Panel . . . . .	3-44
3-59	Abort Dialog . . . . .	3-45
3-60	Confirm Selected, Schedule Aborted . . . . .	3-45
3-61	System Properties - Data Tab . . . . .	3-46
3-62	Open Schedule Dialog - Source Drop-down . . . . .	3-46
5-1	Front of the Atomx XYZ . . . . .	5-6
5-2	Right Side of Atomx XYZ . . . . .	5-7
5-3	Analytical Trap Compartment and Sparger Panel Open . . . . .	5-7
5-4	Plumbing Components . . . . .	5-8
5-5	Plumbing Components . . . . .	5-9
5-6	Electrical Components . . . . .	5-10
5-7	Printed Circuit Board Locations - Atomx XYZ Concentrator . . . . .	5-11
5-8	Printed Circuit Board Locations - Autosampler . . . . .	5-11
5-9	CPU Communication Board (Master Board) . . . . .	5-12
5-10	CPU Communication Board Location . . . . .	5-12
5-11	Multi-Channel Temperature Control Board . . . . .	5-13
5-12	Multi-Channel Temperature Control Board . . . . .	5-13
5-13	DC Valve Control Board . . . . .	5-14
5-14	DC Valve Control Board Location . . . . .	5-14
5-15	Internal Standard Valve Control Board . . . . .	5-15



5-16	Internal Standard Valve Control Board Location	5-15
5-17	Banner Board Location	5-16
5-18	Banner Board	5-16
5-19	XYZ Interface Board (Located Under the XYZ Input/Output and XYZ Control Board)	5-16
5-20	XYZ Interface Board	5-17
5-21	XYZ Input/ Output Board	5-17
5-22	Elevator Drive Board	5-18
5-23	24VDC Power Supply	5-18
5-24	5VDC Power Supply	5-19
5-25	Leak Check Started	5-19
5-26	Instrument Status Panel - Check Standard Pressure	5-28
5-27	Internal Standard Regulator Location on the Valve Manifold	5-29
5-28	Sample Needle	5-30
5-29	Tubing Connections at the Sample Needle Assembly	5-31
5-30	Sparger Connections	5-32
5-31	Analytical Trap Compartment	5-34
5-32	Trap Heater Orientation and RTD Plugs	5-35
5-33	Bake Dialog	5-37
5-34	Elevator Down	5-38
5-35	Autosampler Zones	5-39
5-36	Atomx XYZ TekLink Tools Screen and Align Autosampler Button	5-41
5-37	Autosampler Alignment Wizard - Ready to Begin Alignment	5-42
5-38	Align Zone 1 - Gripper Controls	5-42
5-39	Probe in Gripper	5-43
5-40	Align Zone 1 - Start Alignment Button	5-43
5-41	Align Zone 1 - Place Target	5-43
5-42	Probe Alignment Buttons	5-44
5-43	Target in Location 1	5-45
5-44	Align Zone 1 - Next Landmark Button	5-45
5-45	Align Zone 1 - Test Alignment	5-45
5-46	Align Zone 1 - Prompt to Place Target in Landmark Four	5-46
5-47	Align Zone 1 - Checking Landmark 4	5-46
5-48	Alignment Error	5-46
5-49	Align Zone 1 - Program Zone	5-47
5-50	Align Zone 1 Complete - Select Next to Continue	5-47
5-51	Cancel Alignment Notification	5-48
5-52	Z-Height Alignment	5-48
5-53	Vial in Position 1	5-49
5-54	Z-Height Alignment - Vial Found	5-49
5-55	Z-Height Alignment Complete for All Zones - Program All Zone Heights	5-49
5-56	Z-Height Alignment Complete - Select Next Button	5-50
5-57	Alignment Test Screen	5-50
5-58	Begin Alignment Test	5-51
5-59	Alignment Complete	5-51
5-60	Atomx XYZ Power Entry Module (PEM)	5-53
5-61	PEM Fuse Module Cover Open (Removed for Clarity)	5-53
5-62	Fuse Module Removed	5-54
5-63	Fuse Orientation in Fuse Module	5-54
5-64	Multi-Channel Temperature Control Board	5-55
5-65	Multi-Channel Temperature Control Board Diagram - Main Fuse	5-56
5-66	Multi-Channel Temperature Control Board	5-57
5-67	Multi-Channel Temperature Control Board Diagram - Heater Output Fuses	5-58
5-68	Upgrade Firmware Dialog	5-60
5-69	Benchmark Test	5-61



5-70	Benchmark Test Prompt	5-61
5-71	No Power Flow Chart	5-62
5-72	No Response Flow Chart	5-63
5-73	Low Response Flow Chart	5-64
5-74	Carryover Contamination Flow Chart	5-65
A-1	Atomx XYZ Concentrator Electrical Schematic	A-1
A-2	Atomx XYZ Autosampler Electrical Schematic	A-2
A-3	Atomx XYZ Plumbing Diagram	A-3
A-4	Atomx XYZ - Basic Flow Diagram	A-5
A-5	Atomx XYZ - Waters Flow Diagram - Standby Purge Ready	A-6
A-6	Atomx XYZ - Waters Flow Diagram - Sample Fill	A-7
A-7	Atomx XYZ - Waters Flow Diagram - Sample Transfer	A-8
A-8	Atomx XYZ - Waters Flow Diagram - Purge	A-9
A-9	Atomx XYZ - Waters Flow Diagram - Dry Purge	A-10
A-10	Atomx XYZ - Waters Flow Diagram - Desorb	A-11
A-11	Atomx XYZ - Waters Flow Diagram - Bake Rinse Fill	A-12
A-12	Atomx XYZ - Waters Flow Diagram - Bake Rinse Transfer	A-13
A-13	Atomx XYZ - Waters Flow Diagram - Bake Rinse Drain	A-14
A-14	Atomx XYZ - Waters Flow Diagram - Bake	A-15
A-15	Atomx XYZ - Soils Flow Diagram - Standby/Purge Ready	A-16
A-16	Atomx XYZ - Soils Flow Diagram - DI Transfer to Vial	A-17
A-17	Atomx XYZ - Soils Flow Diagram - Purge	A-18
A-18	Atomx XYZ - Soils Flow Diagram - Dry Purge	A-19
A-19	Atomx XYZ - Soils Flow Diagram - Bake	A-20
A-20	Atomx XYZ - Methanol Flow Diagram - Fill	A-21
A-21	Atomx XYZ - Methanol Flow Diagram - Dispense to Vial	A-22
A-22	Atomx XYZ - Methanol Flow Diagram - Extract Fill	A-23
A-23	Atomx XYZ - Methanol Flow Diagram - Dispense Extract to Glassware	A-24
A-24	Atomx XYZ - Eliminator Flow Diagram - Basic	A-25
A-25	Atomx XYZ - Eliminator Flow Diagram - Ready	A-26
A-26	Atomx XYZ - Eliminator Flow Diagram - Add Defoamer	A-27
A-27	Atomx XYZ - Eliminator Flow Diagram - Rinse	A-28

## List of Tables

1-1	General Specifications	1-5
1-2	Performance Specifications	1-6
1-3	Methods, Applications, and Certifications	1-6
1-4	Liquid Samples	1-7
1-5	Low-Level Solid Samples	1-7
1-6	High-Level Solid Samples	1-7
1-7	Internal Standard Injection	1-8
1-8	Liquid Handling	1-8
1-9	Sample Gas Handling and Requirements	1-8
1-10	Electrical Requirements	1-9
1-11	Computer Requirements and System Control Specifications	1-9
1-12	Valving	1-9
1-13	Heaters and Temperatures	1-10
1-14	Built-in System Tests and Diagnostics	1-10
1-15	System Accessories	1-10
1-16	Atomx XYZ Components	1-11
1-17	Status Light Indications	1-17
1-18	Valve Overview	1-21
2-1	Minimum Computer Requirements	2-4

4-1 Mode Descriptions . . . . .	4-1
4-2 Analytical Trap Recommended Operating Conditions . . . . .	4-15
5-1 Daily Maintenance Checklist . . . . .	5-2
5-2 Weekly Maintenance Checklist. . . . .	5-2
5-3 Monthly Maintenance Checklist . . . . .	5-3
5-4 Quarterly Maintenance Checklist . . . . .	5-3
5-5 Preventative Maintenance Chart . . . . .	5-4
5-6 GC I/O Cable and GC System Reference . . . . .	5-5
5-7 Analytical Trap Recommended Conditioning Temperatures and Times .	5-36
5-8 Alignment Landmark Color Codes . . . . .	5-40
5-9 Atomx XYZ Fuse Ratings (2 IEC 5 x 20 mm Fuses) . . . . .	5-54
5-10 Main Fuse. . . . .	5-57
5-11 Heater Output Fuses . . . . .	5-59

# Atomx XYZ User Manual

---

## Preface

### P.1 Warranty

Refer to [www.teledynetekmar.com](http://www.teledynetekmar.com) for the Terms and Conditions of Sale and the Product Warranty. For questions regarding this policy and its application contact Teledyne Tekmar Customer Support using the information below.

### P.2 Teledyne Tekmar Customer Support Center

**U.S. Phone: (800) 874-2004**

**U.S. Email: [tekmarsupport@teledyne.com](mailto:tekmarsupport@teledyne.com)**

**International Phone (Outside the U.S.): Country Code + 1 (513) 229-7000**

**International Email: [Tekmar\\_Intltech@teledyne.com](mailto:Tekmar_Intltech@teledyne.com)**



#### NOTE

When contacting Teledyne Tekmar Customer Support for troubleshooting, information from the Atomx XYZ TekLink software "About Dialog" may be requested by a Teledyne Tekmar Customer Support Representative. Select Tools Screen>About Button in the software.

### P.3 Essential Instructions



#### NOTE

It is important that you read this page before proceeding!

Teledyne Tekmar designs, manufactures, and tests its products to meet many national and international standards. The Atomx XYZ is a sophisticated technical product and must be properly installed, used, and maintained to ensure that it operates within normal specifications. You must adhere to and integrate the following instructions into your safety program when installing, using, and maintaining the Atomx XYZ. Failure to follow the proper instructions may invalidate the warranty.

- Read all instructions prior to installing, operating, and servicing the product. Follow all warnings, cautions, and instructions marked on, and supplied with the product and this manual. If you do not understand any of the instructions, contact your Teledyne Tekmar Representative for clarification.
- Educate personnel in the proper installation, operation, and maintenance of the product. Only qualified personnel should install, operate, update, program, and maintain the product.
- Install your equipment as specified in Chapter 2: "Installation and Setup" of this manual and according to applicable local and national codes. Connect all products to the required electrical and pressure sources.

- Only trained service personnel should replace blown fuses, and only after identifying and correcting the problem which caused the fuse(s) to blow. For continued protection, replace only with same type and rating of fuse.
- When replacement parts are required, ensure that qualified individuals use replacement parts specified by Teledyne Tekmar. Unauthorized parts and products can affect the product's performance and jeopardize safety. Using look-alike substitutions may result in fire, electrical hazards, or improper operation.
- Ensure that all equipment doors are closed and protective covers are in place (except when maintenance is being performed by qualified personnel) to prevent electrical shock and personal injury.



### WARNING

**DO NOT OPERATE IN AN EXPLOSIVE ENVIRONMENT OR WET ENVIRONMENTS. NEVER USE HYDROGEN OR OTHER FLAMMABLE GAS. VENTING OF THIS GAS CREATES AN EXPLOSIVE HAZARD.**

## P.4 Notations and Hazard Severity Levels

This manual uses **Notations** and **Hazard Severity Levels** to emphasize information that is important for instrument functionality and user and instrument safety. The four levels consist of:



### NOTE

Note is used for information and descriptions to ensure correct usage to prevent damage of the instrument.



### Caution

Cautions identify a potential hazard, which if not avoided, may result in minor or moderate injury. This category can also warn you of unsafe practices, or conditions that may cause property damage.



### WARNING

**Warnings identify a potentially hazardous condition, which if not avoided, could result in death or serious injury.**



### DANGER

**DANGER is limited to the most extreme situations to identify an imminent hazard, which if not avoided, will result in death or serious injury.**

## P.5 Atomx XYZ Safety Symbols Defined

The Atomx XYZ instrument is labeled in compliance with the marking and nomenclature specified in the UL61010-1Ed. 3 (2012) safety standard. The following symbols and their associated signal words are used in the manual and on instrument labels.

L'instrument Atomx XYZ est étiqueté en conformité avec le marquage et la nomenclature spécifiés dans le standard de sécurité UL61010-1Ed. 3 (2012). Les étiquettes ci-dessous et leurs marquages associés sont utilisés dans le manuel et sur l'étiquetage de l'instrument.



**Electrical Hazard!**

**Risque électrique!**



**Warning/Caution! A hazardous or potentially hazardous situation that, if not avoided, will result in product and/or property damage and possible injury and/or death.**

**Danger/Attention! Un risque ou une situation potentielle à risque, qui n'est pas respectée, résultera dans le dommage du produit et/ou des biens et la possibilité de blessures et/ou de mort**



**Fire Hazard!**

**Risque de feu!**



**Burn hazard! Hot surface inside. Allow this area to cool before servicing.**

**Risque de brûlure! Surface chaude à l'intérieur. Attendre le refroidissement de cette zone avant entretien**



**Read the Appropriate Documentation!**

**Lire la documentation appropriée.**



**Skin Contact Hazard! Use protective gloves and other appropriate PPE.**

**Risque au contact de la peau. Utiliser des gants de protection ou autres équipements de protection personnel appropriés.**



**High Pressure Hazard!**

**Risque de haute pression!**



**Risk of Eye Injury. Wear safety glasses and other appropriate PPE.**

**Risque de blessures aux yeux. Porter des lunettes de sécurité et autres équipements de protection personnel appropriés.**



**Pinch Point Hazard! Keep hands and other appendages away.**

**Danger d'écrasement! Garder les mains et autres membres éloignés.**



**Lift Point**

**Point de Levage**

## P.6 Atomx XYZ Safety Labels



**Electrical Ground**

**Prise de terre**

**WARNING: Electrical shock hazard. Do not operate without cover.**



**DANGER: Risque d'électrocution. Ne pas utiliser sans capot.**



**WARNING: To avoid electrical shock, disconnect supply before changing fuses.**

**DANGER: Pour éviter le risque d'électrocution, débrancher l'alimentation avant de remplacer les fusibles.**



**WARNING: For continued fire protection, replace with same type and rating of fuses.**

**DANGER: Pour prévenir le risque d'incendie, remplacer avec des fusibles de même type et de même caractéristique.**



**WARNING: Remove the power cable before performing maintenance and/or servicing the instrument.**

**DANGER: Débrancher le câble d'alimentation avant toutes interventions de maintenance et/ou d'entretien sur l'instrument.**



**CAUTION: Maximum pressure for carrier gas is 200 PSI (13.8 bar).**

**ATTENTION: La pression maximale pour le gaz porteur est de 200 PSI (13.8 bar).**



**CAUTION: Inlet pressure recommended for sample gas is a minimum of 65 PSI to maximum of 100 PSI (4.5 to 6.9 bar).**

**ATTENTION: La pression d'entrée recommandée pour le gaz échantillonné doit être comprise entre 65 PSI et 100 PSI (4.5 to 6.9 bar).**



**Power entry module requires:**

**La puissance de module d'entrée nécessite:**

**2 IEC 5 x 20 mm fuses**

**100V operation**

**T 10.0A – 250v**

**115V operation**

**T 10.0A – 250v**

**230V operation**

**T 5.0A – 250v**

## P.7 Working Safely



# DANGER

**If the equipment is used in a manner not specified herein, the protection provided by the equipment may be impaired!**



The Atomx XYZ weighs 95 lbs (43.1 kg). If this weight exceeds your lifting ability, lift and position the Atomx XYZ with two people. Lift and position the Atomx XYZ using the designated lift points.

Route tubing drain lines to slope downward only. Do not extend tubing into the waste bottle more than 3" to 5" (7.6 to 12.7 cm). Failure to follow these directions may result in improper drainage of the Atomx XYZ.

Please be aware that if the Atomx XYZ, its components, and/or accessories are used in a manner not specified by Teledyne Tekmar, protection by the equipment may be impaired.

Only use replacement parts supplied or approved by Teledyne Tekmar when performing maintenance on the Atomx XYZ. Use of unapproved parts could result in damage to the instrument, as well as personal injury.

Running an improper method may damage the Atomx XYZ. Setting up a new method should be performed by personnel who are properly trained, knowledgeable, and well acquainted with the Atomx XYZ.

Ensure that the installation location allows the Atomx XYZ to be easily turned off and the power cord disconnected, in the event of an emergency.



The circuit used to power the Atomx XYZ should be protected by a Certified/Listed 15/20 Circuit Breaker for short circuit protection.

Do not plug the Atomx XYZ into an extension cord. An extension cord may overheat and cause a fire.

Only replace the Atomx XYZ mains supply AC power cable with a UL listed cable of the same current and voltage rating.

Ensure the power cable is routed away from, and is not capable of contacting, any hot surface.

Only replace fuses with those of the same type and rating. Refer to Section 5.19 "Power Entry Module (PEM) Fuse Replacement".

To avoid the risk of fire and maintain optimum instrument performance, install the Atomx XYZ on a non-flammable surface and maintain a minimum 6" (15.24 cm) perimeter around the unit that is unobstructed by flammable material or other equipment.



NEVER use hydrogen or other flammable gas with the Atomx XYZ. Venting of this gas creates an explosion hazard. Follow the manufacturer's directions for safe handling of gas and chemicals. Also refer to the Safety Data Sheets (SDSs) for information on specific chemicals.





To avoid injury to yourself or damage to the Atomx XYZ, do not exceed the recommended pressure settings. Observe safety regulations when handling pressurized gas. For more information see Matheson™ Gases Data Book (available from the Matheson Company, East Rutherford, New Jersey).



Sample and associated waste may contain hazardous and toxic substances. Follow the proper safety and health practices, as well as anticipating all regulatory limitations before using or disposing of chemicals.



To avoid electrical shock:

- The interior of the instrument is an electrical shock hazard. Do not operate without the panels, covers and guards installed. To avoid electrical shock, turn OFF and unplug before servicing.
- Plug the power cord into a properly grounded outlet.
- Be alert for environmental, shock, or other hazards in the event that tubing or any other liquid bearing object in the instrument bursts on the inside of the instrument. Before cleaning up, unplug the instrument and determine the nature of the liquid that was spilled. Use extreme caution and apply the appropriate clean-up procedures.



Pinch Point Hazard! The Atomx XYZ has three pinch point hazard areas, the area above the autosampler vial rack in which the autosampler arm operates, the vertical path of the sample vial elevator, and the vertical path of the syringe. While the instrument is powered on and operating, keep hands and appendages away from these areas.

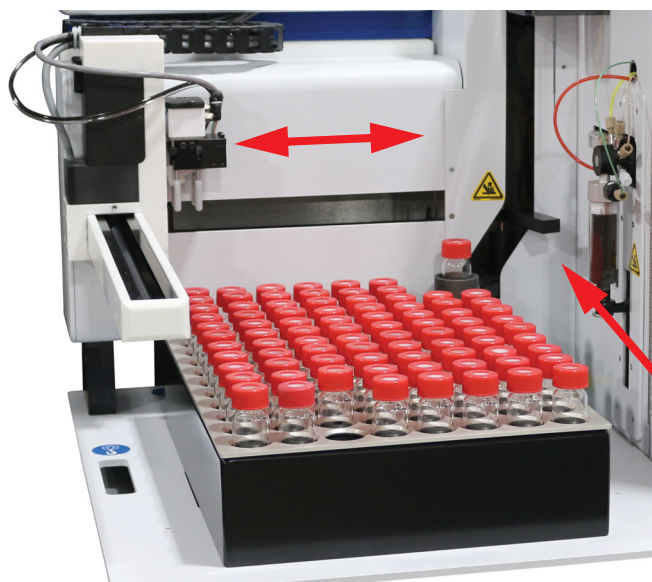

Autosampler Arm

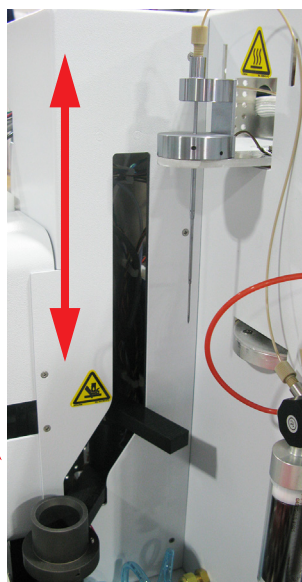

Elevator



Syringe Drive



Risk of Eye Injury. Wear safety glasses and other appropriate PPE. It is recommended that safety glasses be worn at all times in the presence of pressurized gases.



This instrument contains heated components. Touching any heated zone during the operation of the instrument can cause a burn. The system's heaters will activate when their set-points are above actual temperatures. Keep all instrument panels fastened when operating the Atomx XYZ. To prevent injury, allow areas with this label to cool before servicing.

When working near the analytical trap compartment, sample mount, soil valve, sample needle, sample vial cup, moisture control system (MCS), 6-port valve (in the valve oven area), sample transfer line to the GC and the 4-way tee, allow the components to cool to room temperature.

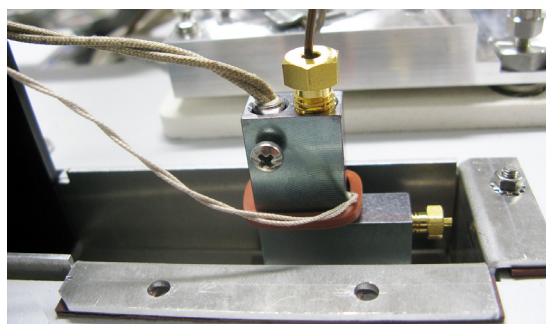

**MCS**

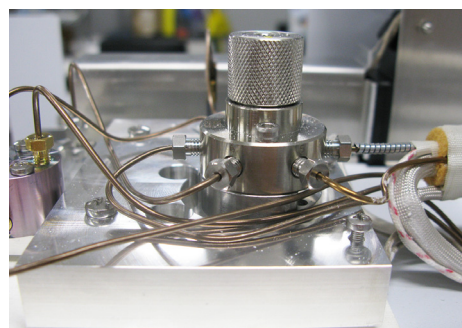

**6-Port Valve**

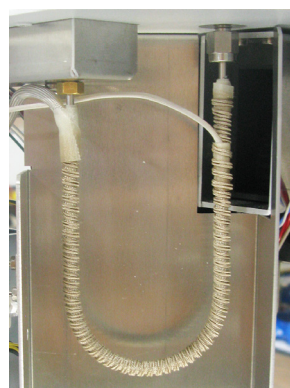

**Analytical Trap**

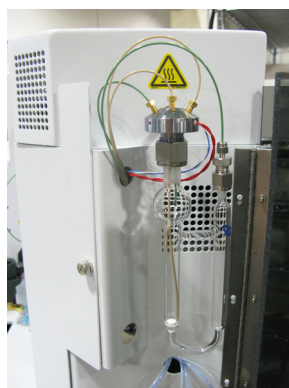

**Sample Mount**



**Sample Needle & Cup**



**Sample Transfer Line**

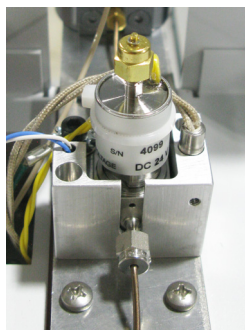

**Soil Valve**

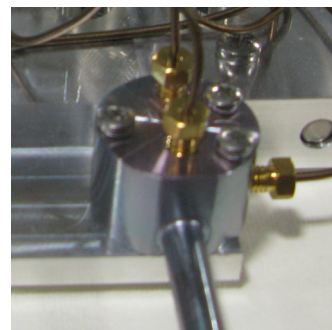

**4-Way Tee**

## P.8 Explanation of Regulatory Marks

### P.8.1 Unit Disposal

The affixed label indicates that you must not discard this electrical/electronic product in domestic household waste, in compliance with the European Waste Electrical and Electronic Equipment Directive (WEEE, 2002/96/EC).



Please contact Teledyne Tekmar or your local distributor for instructions on returning the system for proper disassembly and disposal. Contact Teledyne Tekmar Customer Support.

### P.8.2 CE Mark



The CE mark is a registered trademark of the European Community. This CE mark shows that the product complies with all the relevant European Legal Directives.



# Atomx XYZ User Manual

---

## Chapter 1: Introduction

### 1.1 Atomx XYZ with Methanol Extractions Overview

The Atomx XYZ is a microprocessor-controlled Volatile Organic Compounds (VOCs) sample preparation system using the Purge and Trap (P&T) analytical technique. The system combines autosampling and concentration into one system for the analysis of solid and liquid samples including drinking water, waste water, soils, and sludges. The Atomx XYZ completely automates sample preparation and purge and trap steps including vial handling, sample volume measurement, standard injections, dilutions, rinsing, purging, desorption and baking.

The Atomx XYZ single needle design transfers liquid sample aliquots from the vial to the sparger. Low-level solid samples are purged directly in the vial, transferring to the trap. High-level solid samples can be automatically extracted via Methanol and diluted prior to transfer to the sparger for analysis.

Atomx XYZ offers all the capabilities needed for compliance with EPA Method 5035 for the analysis of volatile organics in soil samples, including a true closed-system technique for sample handling. The closed-system sampling technique ensures the integrity of the sample during the sample preparation process, greatly minimizing volatile organics loss.

### 1.2 Purge and Trap Background

#### 1.2.1 Purge and Trap Fundamentals

When using a concentrator system, it is not essential to understand how it works. However, a good grasp of the fundamentals helps you prevent problems and assists you when you are faced with tasks such as method development and troubleshooting. This section is not intended to be a full theoretical evaluation of P&T gas chromatography.

The primary purpose of this section is to help develop an understanding of how and why compounds are concentrated. While gas chromatography is a very powerful analytical tool, it does have several limitations. Many different techniques have gradually been developed to overcome these limitations. These techniques are for a wide variety of sample types. The limitations which P&T concentration is designed to overcome, include:

1. Lack of sensitivity.

GC detectors provide remarkable sensitivity. However, there are a number of areas where greater sensitivity is necessary. These include:

- Environmental Analysis - Many pollutants must be measured at low levels; sometimes, in the sub-part per billion (ppb) range.
- Flavor and Fragrance Analysis - The human nose is one of the most sensitive detectors in existence. To provide an analytical system with comparable sensitivity, some method of concentration is required.



2. Inability to tolerate water injections.

Many GC columns and detectors do not perform well in the presence of water. Water may drastically reduce the lifetime of the column and adversely affect the detector performance.

3. The sample must be in vapor or vaporizable form.

Gas chromatography operates as an interaction between vapor and liquid phases. The sample must start out as a vapor. For this reason, there are many samples, such as pollutants in soil or flavors in solid food, which cannot be directly introduced into a GC.

The ability to analyze VOCs is a vital part of environmental monitoring, outgassing studies, flavor or fragrance analysis, among others. P&T is a technique that separates the VOCs from a matrix. After separation, the VOCs are then concentrated and injected into the GC for separation and detection.

### 1.2.2 Brief History

In the 1960's, P&T was used in the study of bodily fluids. In the mid-to-late 1970's, P&T became a technique that was well-known and widely applied due the need to monitor VOCs in drinking water. Using this technique, it was possible to detect sub-ppm level VOCs of a wide variety. Today, P&T is routinely applied in the environmental area for the analysis of VOCs in soil and water. The arrival of microprocessor-driven systems allows the concentrator to be more precise and automated, giving the operator more time for other projects.

## 1.3 Purge and Trap Operation Overview

A measured amount of sample is placed in a sealed vessel. The sample is purged with inert gas, causing VOCs to be swept out of the sample. The VOCs are retained in an analytical trap, which allows the purge gas to pass through to vent. The VOCs are then desorbed by heating the trap, injected into the GC by back-flushing the trap with carrier gas, and separated and detected by normal GC operation.

While purging and sweeping the sample with an inert gas sounds simple, it is in reality a very complex process. Purging a sample to extract analytes is a gas extraction. There are many factors that affect the efficiency of this extraction. The amount of each compound purged is proportional to both its vapor pressure and its solubility in the sample. Both of these are, in turn, affected by the sample temperature. Consider the case of a sample sealed in a closed vial. Above the sample is a vapor space, which is usually referred to as the headspace. If you allow the sample sufficient time, VOCs in the sample will migrate into the vapor space. After a certain period of time at a constant temperature, the concentration of the volatile compounds in each phase will be stabilized, the chemical system will have reached equilibrium (Figure 1-1).

Figure 1-1 Headspace Equilibrium Diagram

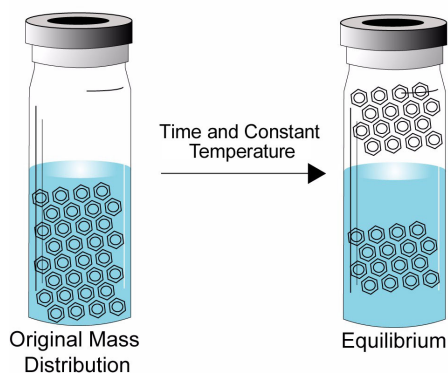

At this point a portion of the headspace can be removed and injected into the GC for analysis. This technique is known as Equilibrium Analysis or Static Headspace Analysis. The amount of material in the vapor phase will be proportional to the partial pressure of the component. The equation below describes the phase distribution of sample.

$$P_T = P_1 + P_2 + P_3 + \dots + P_n = X_1P_1^\circ + X_2P_2^\circ + X_3P_3^\circ + \dots + X_nP_n^\circ$$

where:

$P_T$  = total vapor pressure of system

$P_1$ , etc. = partial pressure of each compound

$P_1^\circ$ , etc. = vapor pressures of the pure compounds

$X_1$ , etc. = mole fractions of each compound

In purging a sample, the system is no longer at equilibrium. This is because the VOCs that move into the vapor phase are constantly being removed by the purge gas. Under these circumstances, there is no migration of components from the vapor to liquid phase. This means that the partial pressure of any individual component above the sample at any time is essentially zero. This encourages even greater migration of the VOCs into the vapor phase, extracting the VOC from the sample more efficiently. Purging a sample for 10 minutes with helium (at a flow rate of 50 ml/min.) results in a more efficient extraction of volatiles than equilibrium, using 500 ml headspace. This purging technique is called Dynamic Headspace Analysis. For aqueous matrices, the increase in efficiency can be upwards of 100 fold, using dynamic versus static headspace analysis.

Extraction efficiency increases with an increase in sweep volume. Sweep volume, a function of sweep time and flow rate, is the amount of purge gas used to extract the analytes. Since the analytes are being trapped on a sorbent bed, there are limitations to the sweep times and flow rates that can be used. These limitations are determined by the compounds of interest in the sample and the sorbent material used in the trap.

### 1.3.1 Trapping, Adsorption and Desorption

An analytical trap is essentially a short gas chromatograph column. Compounds entering the trap will slowly elute with a measurable retention volume. Retention volume is the amount of purge gas that passes through the trap before the elution of the analytes from the sorbent materials.

The requirements of an analytical trap are as follows:

- At low temperatures, it must retain the analytes of interest while allowing oxygen and water to pass through unimpeded.
- Upon heating, it must release the analytes quickly and efficiently.
- When heated, it must show stability and not contribute to volatiles.
- It must operate without causing any catalytic reactions.
- It should have a reasonable price and lifetime.

At lower trap temperatures, retention volumes are high. At higher desorption temperatures, retention volumes are much smaller, allowing rapid transfer to the GC.

When elution does occur, it is usually referred to as breakthrough, and the retention volume, at which breakthrough occurs, is often referred to as the breakthrough volume. Sorbent materials are usually chosen so that the breakthrough volume is high for the analytes of interest and low for water. Care must be taken that the sorbent chosen does not retain the analytes too strongly or efficient desorption may not be possible.

Traps containing combinations of sorbents are often used to enhance performance. The trap is packed with the weaker sorbent on top. The stronger sorbent is placed below the weaker sorbent. Less volatile analytes are retained by the weaker sorbent as they are not effectively desorbed if they are trapped on the stronger sorbent. Therefore, the less volatile analytes fail to reach the stronger sorbent. Only the more volatile analytes reach the stronger sorbent; and because of their volatility, these analytes can be efficiently desorbed. The desorption is carried out by back-flushing the trap, ensuring that the less volatile, or heavier, analytes never come in contact with the stronger sorbent.



## 1.4 Atomx XYZ Specifications

For additional information on installation requirements refer to Chapter 2: "Installation and Setup".

<b>Table 1-1 General Specifications</b>	
Part Numbers	Atomx XYZ (100-120 VAC): 15-3200-100 Atomx XYZ (220-240 VAC): 15-3200-200 Atomx XYZ (100-120 VAC) with Guardian Foam Sensor and Foam Eliminator: 15-3200-1E0 Atomx XYZ (220-240 VAC) with Guardian Foam Sensor and Foam Eliminator: 15-3200-2E0 Atomx XYZ (100-120 VAC) with Vial Chilling: 15-3200-10C Atomx XYZ (220-240 VAC) with Vial Chilling: 15-3200-20C Atomx XYZ (100-120 VAC) with Guardian Foam Sensor and Foam Eliminator & Vial Chilling: 15-3200-1EC Atomx XYZ (220-240 VAC) with Guardian Foam Sensor and Foam Eliminator & Vial Chilling: 15-3200-2EC
Dimensions	Height: 19.5 in (49.5 cm) Width: 27.6 in (70.1 cm) Depth: 23 in (58.4 cm)
Weight	95 lbs (43.1 kg)
Environmental Specifications	Operating Temperature: The system is capable of operating in lab temperatures between 10 ° and 30 °C (50 ° and 86 °F). Relative Humidity: 10% to 90%
Corrosion	The front cover and autosampler vial rack are corrosion resistant to waters within a pH range of 1-10.
GC Interface	Designed to interface with virtually all commercially available GC instruments.
Column Compatibility	Teledyne Tekmar recommends the use of 20 m x 0.18 mm ID Fast Volatiles columns.

**Table 1-2 Performance Specifications**

Sample Types	<p>Liquid samples including drinking water and wastewater.</p> <p>Liquid samples containing up to 15 mm of sediment when measured from the bottom of an upright 40 mL vial.</p> <p>Low-level solid samples (including all types of soils and sediments) sampled via direct purge in the vial in accordance with USEPA 5035 low-level soil methodology.</p> <p>High-level solid samples (including all types of soils and sediments), sampled via automated Methanol Extraction and subsequent dilution in accordance with USEPA 5035 high-level soil methodology.</p>
Sample Capacity	84 Positions for 40 mL VOA vials.
Vial Size	Nominal 40 mL capacity, single hole cap with PTFE-faced silicone septum, per USEPA specifications; 3-3/4" (9.5 cm) high without cap and septum; 1-1/16" (2.7 cm) O.D.; 24 mm ID cap for water sampling.
Vial Transport Device	Pick and place XYZ robotic autosampler arm and elevator design using stepper motors, optical encoders and magnetic sensors for accurate positioning.
Cycle Time	<p>The cycle time is <math>\leq</math> 20 minutes when using an 11 minute purge time. This time includes purge, desorb, bake and cool down to "purge ready".</p> <p>Note: This specification assumes an ambient room temperature between 20-22 °C (68 °-71.6 ° F).</p>
Maximum Sample Concentration	1 ppm. High level samples should be pre-screened with HT3 or Versa Headspace Sampler.

**Table 1-3 Methods, Applications, and Certifications**

Official Methods	<p>USEPA 502.1, 502.2, 524.2, 524.3, 524.4, 503.1</p> <p>USEPA 601,602, 603, 624</p> <p>USEPA 8010, 8015, 8020, 8021, 8030, 8240, 8260, 5030, 5035</p> <p>ASTM and Standard Methods</p> <p>Massachusetts VPH and GRO Methods</p>
Applications	Environmental, Food and Beverage, Petrochemical, and Plastics and Polymers
Certifications	<p>The unit has successfully completed all appropriate EMC, EMI, and safety requirements per UL, FCC, CSA, and IEC.</p> <p>IEC 61010-1:2010 Ed.3+C1;C2</p> <p>IEC 61010-2-051:2015Ed.3</p> <p>IEC 61010-2-010</p> <p>UL 61010-1:2012Ed.3</p> <p>CSA C22.2#61010-1:2012Ed.3</p> <p>UL 61010-2-051:2015Ed.3</p> <p>CSA C22.2#61010-2-051:2015Ed.3</p> <p>UL 61010-2-010:2015 Ed.3</p> <p>CSA C22.2#61010-2-010:2015Ed.3</p> <p>IEC 61326-1</p> <p>Machinery Directive 2006/42/EC</p> <p>Designed and manufactured under a quality system registered to ISO 9001:2015. A Declaration of Conformity is shipped with the Atomx XYZ.</p>

<b>Table 1-4 Liquid Samples</b>	
Sample Glassware	The system is capable of operation with 5 or 25 mL frit or fritless u-shaped sparge vessels. 5 mL frit comes standard.
Sample Dilutions	Programmable automatic aqueous sample dilutions of 1:100, 1:50, 1:25, 1:10, 1:5, 1:2.
Sparge Vessel Heater (Optional)	The system can be equipped with an optional sparge vessel heater that will heat the sample from 35 °C to 100 °C.
Blanks	Automatic blanks can be pulled from the DI water reservoir and spiked with standard, this allows all autosampler positions to be used for samples.
Vial Cooling (Optional Chiller Tray)	Cools samples to 4 °C (requires an external recirculating cooling bath).
Cooling Bath Connection	Inlet and outlet hose connections require 1/4" (0.64 cm) ID rubber tubing.

<b>Table 1-5 Low-Level Solid Samples<sup>a</sup></b>	
Sample Needle	A patented 3-stage needle (US Patent 6,706,245) allows for DI water and standards to be directly added to the vial where the solid sample will subsequently be purged.
Vial Heater (Vial Cup on Elevator)	Variable heat control from 35 °C to 100 °C.
Mixing	The solid sample can be mixed using a stir bar at four selectable speeds: slow, medium, high, and agitate (back and forth).

a. Includes all types of natural soils and sediments. Sample procedure: direct purge in vial per USEPA 5035 low-level soil methodology.

<b>Table 1-6 High-Level Solid Samples<sup>a</sup></b>	
Extraction	Methanol can be added directly to the vial containing a solid sample, where it is mixed and allowed to settle. The methanolic extract is then pulled from the vial and diluted for automated Purge & Trap analysis on the system. If high-level solid were sampled in the field with the extraction solvent, the sample can be mixed and allowed to settle prior to the methanol being pulled and diluted. The extraction method offered complies with USEPA Method 5035 for high-level soil samples.
Matrix Spike	The system is configured to allow a standard spike to be added directly to the solid sample when the methanol is added for the extraction.
Extraction Dilutions	Programmable automatic dilutions of methanolic extract of 1:100 or 1:50, 5 mL sample volumes.

a. Includes all types of soils and sediments. Sample procedure: Automated methanol extraction and subsequent dilution per USEPA 5035 high-level soil methodology.

**Table 1-7 Internal Standard Injection**

Internal Standard Injection Systems	Three standard injection systems utilizing 2-way dosing valves mounted on an internal valve manifold.
Capacity	Up to 20 µL in 1 µL, 2 µL, 5 µL, 10 µL and 20 µL increments.
Precision	< 10% RSD measured by GC/FID for Fluorobenzene and Bromofluorobenzene, (n=7).
Accuracy	1 µL ± 0.1 µL.
Consumption	1 µL per 1 µL injection.
Standard Vessels	Three 15 mL standard vessels, UV-protected for added standard stability. Standard vessels are sealed under pressure for standard concentration integrity.

**Table 1-8 Liquid Handling**

Sample Liquid Handling	Sample syringe (25 mL) dispenses variable volumes of water from 0 to 25 mL in 0.1 mL increments.
Sample Precision	< 1% RSD (n=7 @ 5mL delivery volume measured by weight).
Sample Liquid Path	Glass, PEEK™, Ultem™ and PTFE for syringe handling. 1/16" (0.16 cm) O.D. PEEK tubing for liquid transfer.
Water Supply	Requires use of a blank DI water reservoir (included).
Methanol Supply	The system requires a supply of Purge & Trap grade methanol if the methanol extraction methods or the methanol rinse cleaning technique are to be used.
Cleaning	The entire liquid sample pathway can be rinsed using a combination of the methanol rinse and the high-temperature DI water rinse (US Patent 6,280,688) cleaning techniques. User defined rinse volume and number of rinses for the needle and glassware.

**Table 1-9 Sample Gas Handling and Requirements**

Sample Gas Requirements	Ultra-high purity (99.999%) nitrogen or helium < 0.5 ppm hydrocarbon tested.
Incoming Gas Pressure	65 - 100 psi (4.48 bar - 6.89 bar)
Sample Gas Pathway	1/16" (0.16 cm) OD Inertium® coated tubing. SilcoTek® treated fittings including sample needle. Sample pathway temperature variable from 35 to 250 °C.
Electronic Mass Flow Controller	System is capable of controlling flow rates between 5 ml/min to 500 ml/min, variable between each mode of operation (US Patent 7,651,866).
Electronic Pressure Monitor	Automatic leak check and over-pressure sensing capability. Ability to record purge and bake pressure for each sample.

**Table 1-10 Electrical Requirements**

Voltage Requirements	100-120 VAC +/- 10%, 50/60Hz, 10.0A, 1150W 220-240 VAC +/- 10%, 50/60Hz, 5.0A, 1150W
External Circuits	The circuit used to power the Atomx XYZ should be protected by a Certified/Listed 15/20 Circuit Breaker for short circuit protection.  The AC Power Cable supplied with the Atomx XYZ is compliant with applicable safety standards.  Supplied USB communication cables are of proper type jacketing.

**Table 1-11 Computer Requirements and System Control Specifications**

Operating System	Atomx XYZ TekLink software in a Windows® 7 or greater environment via USB. Windows® 10 is recommended.
Instrument Control	Atomx XYZ TekLink software via USB cable.
Language	Atomx XYZ TekLink can easily be translated into any language via single file modification.
Method Storage	Infinite method storage including pre-programmed default methods for water, soil, and methanol extraction.
Method Scheduling	Soil or water samples can be run from any position in the sample sequence. Up to three internal standards can be added to any user-specified position. Multiple runs can be made from the same vial (not recommended).
GC Communication	GC handshaking through relay contact closures and Transistor-Transistor Logic (TTL).
System History	The system records a complete history of all sample, schedule, method, instrument and error information.
Revision Control	The system records and saves changes to methods, schedules and configurations. The revision number is shown on the printed method or schedule.

**Table 1-12 Valving**

Solenoid Valves	9 (standard configuration) or 11 (optional Guardian Foam Sensor and Eliminator configuration) 24 VDC rocker style valves, mounted on an Ultem® Manifold.
Soil Valve	On/Off heated solenoid, 24 VDC.
6-port Valve	2-position, heated 6-port valve actuated with a 24 VDC motor with encoder feedback.
Standard Addition Valves	Three 24 VDC dosing valves mounted on the Ultem Manifold.
6-Port Syringe Valve	The 6-port Syringe Valve is a multi-port selection valve which allows for liquids to be drawn into the syringe and then the syringe contents to be dispensed.

**Table 1-13 Heaters and Temperatures**

Transfer Line	Variable Heat Control from 35 °C to 250 °C.
6-port Valve	Variable Heat Control from 35 °C to 250 °C.
Sample Mount	Variable Heat Control from 35 °C to 100 °C.
Moisture Control System	Variable Heat Control from 40 °C to 200 °C.
Analytical Trap	Variable Heat Control from 40 °C to 350 °C.
Analytical Trap Ramp Rate	Heats from ambient to 250 °C in less than 20 seconds.
Analytical Trap Control	Overshoot within 15% and Undershoot 5% (at 250 °C)
Analytical Trap Cooling	Trap Heater cools from 250 °C to 40 °C in 70 seconds.
Vial Heater	Variable Heat Control from 35 °C to 80° C (soil methods) and 35 °C to 60 °C (water methods).
Soil Valve	Variable Heat Control from 35 °C to 125 °C.
Hot Water Heater	Variable Heat Control from 35 °C to 90 °C.
Spurge Vessel (optional)	Variable Heat Control from 35 °C to 100 °C.
Temperature Zone Equilibrium	For all zones other than the sample heater, temperature changes equilibrate within 10 minutes or at 10 °C/min, whichever is longer.
Uniformity	Temperatures will be within 10% of measured temperatures after 30 minutes of equilibration.

**Table 1-14 Built-in System Tests and Diagnostics**

Electronic Leak Check	Ability to leak check the entire sample pathway using an automated system leak check process. Once a leak has been identified, the system will check independent sub-systems for leaks.
Benchmark Test	The system has a mode that will allow for full electromechanical testing including: valving, heaters, vial handling systems, liquid delivery system, inputs and outputs.
Diagnostics	The system offers independent control of all valves, vial handling mechanisms and syringe drive for troubleshooting.
Unit Status Light	The unit status light indicator changes color to indicate standby, schedule running and error states.

**Table 1-15 System Accessories**

Spurge Vessel Heater	An optional spurge vessel heater that heats liquid samples to temperatures between 35 °C and 100 °C during the Purge Mode.
Vial Cooling	An optional chilling plate that allows sample vials to be held at temperatures down to 4 °C until they are sampled.
Guardian Foam Sensor and Eliminator (Optional)	Optional Guardian Foam Sensor and Foam Eliminator senses foam, stops purge, and adds defoaming agent for samples prone to foaming.

## 1.5 Atomx XYZ Component Overview

**Table 1-16 Atomx XYZ Components**

Component	Function
<b>XYZ Autosampler Arm</b>	Picks up the sample vial and places it in the sample vial cup of the elevator assembly for sampling.
<b>Elevator Assembly/Sample Cup</b>	Once the sample vial is placed in the sample vial cup, the elevator lifts the vial to the sample needle for analysis.
<b>Sample Mount /Sparger</b>	Sample gas is passed through the sample in the sparger and then conveyed through the heated sample mount.
<b>Sample Heater Jacket Assembly for all Glassware Types (Optional)</b>	Heats the sparger between the range of 20-90 °C.
<b>Mixer Assembly</b>	Allows for a magnetic stir bar ("pill" shape recommended) to be added to the sample vial to mix solid samples during the purge process or methanol extraction.
<b>Guardian Foam Sensor and Foam Eliminator (Optional)</b>	Recognizes foaming during sample purge, adds defoaming agent and rinses the sample lines prior to attempting to rerun the sample. Two additional solenoid valves add anti-foam to foaming samples and rinse the anti-foam lines between samples.
<b>Unit Status Light</b>	Indicates standby, schedule running and error states.
<b>Sample/Purge Gas Inlet</b>	The inlet introduces the sample gas (helium or nitrogen) from the blue 1/8" (0.32 cm) sample gas tubing to the sparger. The sample gas then carries VOCs onto the analytical trap.
<b>Mass Flow Controller (MFC)</b>	Monitors and precisely controls the gas flow rates throughout the entire purge and trap process.
<b>Sample Pathway</b>	An inert sample pathway with treated fittings.
<b>Sample Needle</b>	A patented 3-Stage sample needle (US Patent 6,706,245) that displaces sample from the vial (versus aspirating per USEPA methodologies), purge in the vial and complete methanol extraction.
<b>Analytical Trap</b>	Captures VOCs by adsorption. The trap is then heated causing VOCs to desorb from the trap and be carried to the column of the GC.
<b>Analytical Trap Heater Jacket and Resistance Temperature Detector (RTD)</b>	The analytical trap heating jacket heats the analytical trap to a consistent temperature defined in the Atomx XYZ TekLink software. The Resistance Temperature Detector (RTD) in the heating jacket verifies this temperature to the software.
<b>Vial Chiller Plate (Optional)</b>	Allows sample vials to be held at temperatures down to 4° C until they are sampled.
<b>Moisture Control System (MCS)</b>	Allows water in the sample gas to be condensed and then removed prior to introduction to the GC column.
<b>Carrier Gas Inlet Line</b>	The inert tubing that runs down the side of the heated transfer line from the GC. The carrier gas is used to desorb VOCs off the analytical trap.
<b>Heated Sample Transfer Line to GC</b>	The inert tubing that runs next to the carrier gas inlet line to the GC. Carrier gas in the sample transfer line carries desorbed VOCs back to the GC.
<b>Solenoid Valves</b>	Valves mounted on the valve manifold and actuated according to the mode of analysis (Purge, Bake, Drain and Vent).  If the system is equipped with the Foam Eliminator option, the valve manifold will have two additional solenoid valves.
<b>6-Port Valve</b>	The 6-Port valve is a two-position valve that routes the purge and trap concentrator flows according to each mode of operation. The 6-Port Valve is actuated by the two-position actuator control module.

**Table 1-16 Atomx XYZ Components (Continued)**

<b>Component</b>	<b>Function</b>
<b>6-Port Syringe Valve</b>	The 6-port syringe valve is a multi-port selection valve which allows for liquids to be drawn into the syringe such as hot or cold water, methanol, and water from sample vials. This valve can then be used to select where to dispense the contents of the syringe including the sample glassware, the needle, or to waste. Gas flow entering the side port of the syringe can also be distributed to these same destinations through the 6-port valve.
<b>Soil Valve</b>	A heated valve used for solid (soil) samples purged in the vial (with or without methanol extraction).
<b>4-Way Heated Tee</b>	Directs flow of purge gas from the sample mount.
<b>24VDC Power Supply</b>	Supplies 24V Direct Current (DC) to the Atomx XYZ valves and motors.
<b>5VDC Power Supply</b>	Supplies 5V Direct Current (DC) to the Atomx XYZ Printed Circuit Boards (PCBs).
<b>Multi-Channel Temperature Control Board</b>	Responsible for all AC control and RTD feedback for the standard temperature zones.
<b>CPU Communication Board (Master Board)</b>	Communicates to the GC via GC I/O cable and the controlling PC via the USB Port.
<b>DC Valve Control Board</b>	Actuates the Atomx XYZ solenoid valves, as well as the analytical trap and the Moisture Control System (MCS) cooling fans.
<b>Internal Standard Valve Control Board</b>	Controls all Internal Standard valve outputs.
<b>Banner Board</b>	Controls the status indicator LED.
<b>XYZ Main Board</b>	Controls all autosampler arm movements.
<b>XYZ Interface Board</b>	Responsible for communications between the Main Board and the autosampler.
<b>XYZ Input/Output Board</b>	Controls the XYZ autosampler arm inputs and outputs.
<b>USB Communication Cable</b>	Conveys data from the Atomx XYZ instrument to the Atomx XYZ TekLink software installed on the controlling PC.



### 1.5.1 Sample Mount and Sparger

The front panel contains a heated sample mount and glass sparge vessel. The sample mount is heated via the 6-port valve oven plate on one end and a cartridge heater inside the mount itself. A standard 5 mL frit sparger is included with the Atomx XYZ. The following options are also available:

- 25 mL frit sparger
- 5 or 25 mL fritless sparger

Figure 1-2 Sample Mount and Sparger

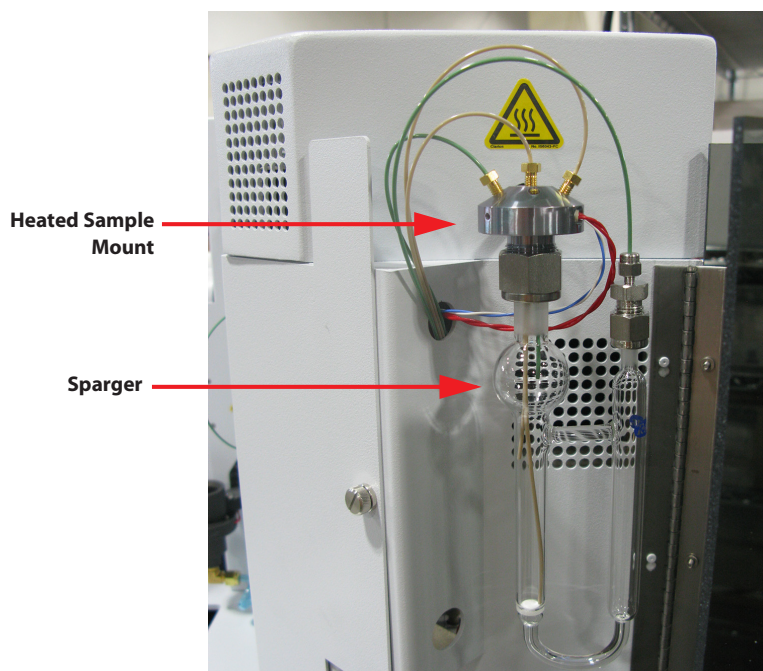

### 1.5.2 Vials

The standard USEPA-approved 40 mL glass vial is commonly used for environmental samples. Vials should have a nominal 40 mL capacity, single hole cap with PTFE-faced silicone septum (per USEPA specifications), measure 3-3/4" (9.5 cm) high without cap and septum and have an Outside Diameter (OD) of 1-1/16" (2.7 cm).



#### NOTE

Vials cannot exceed 1.115" (2.83 cm) O.D. including labels.

Figure 1-3 Maximum Vial Dimensions

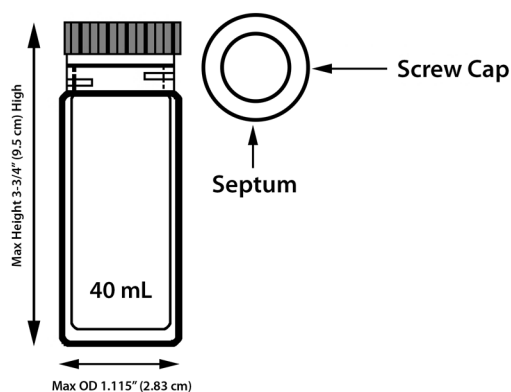

### 1.5.3 Internal Standard Pressure Regulator

The Atomx XYZ has an internal standard pressure regulator located on the valve manifold. The internal standard pressure regulator controls pressure to the three internal standard vessels, as well as the system's sweep modes (i.e. Presweep A&B).

### 1.5.4 Internal Standard Vessels

Atomx XYZ is equipped with three 15 mL amber internal standard vessels. The amber color prevents transmission of UV radiation, preserving standard integrity. Vessels are sealed with a PEEK cap to prevent adsorption and contamination of the standard solution. From left to right the standard vessels are referred to as STD1, STD2, and STD3.

Each standard vessel is pressurized to 7 psi and can deliver spikes of 2  $\mu\text{L}$ , 5  $\mu\text{L}$ , 10  $\mu\text{L}$ , or 20  $\mu\text{L}$  to each sample. Each standard has a maximum volume of 20  $\mu\text{L}$ . A maximum of 60  $\mu\text{L}$  can be added to each sample, if all three standards are used. Any combination of the three internal standards vessels can be used.

Figure 1-4 Internal Standard Vessels



### 1.5.5 Syringe Drive with Sweepable 25 mL Syringe

The Atomx XYZ has a 25 mL sweepable sample syringe that can accurately dispense 0 to 25 mL of liquid in 0.1 mL increments. The sweep port of the syringe is equipped with an in-line check valve and is connected to a pressurized gas source. The sweep port allows the syringe to be swept between samples, and between movements, to improve precision and accuracy of the delivery volume and to prevent contamination. Also refer to "6-Port Syringe Valve".

Figure 1-5 Syringe

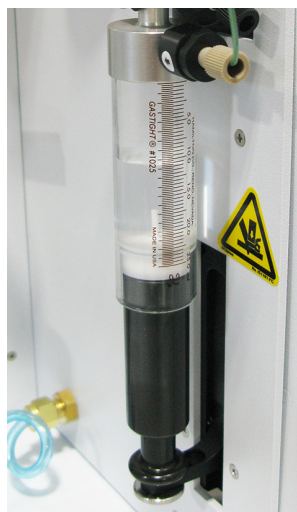

### 1.5.6 Sample Needle

The Atomx XYZ uses a patented 3-stage sample needle to displace sample from the vial (versus aspirating per USEPA methodologies), purge in the vial and complete methanol extractions.

Figure 1-6 Sample Needle

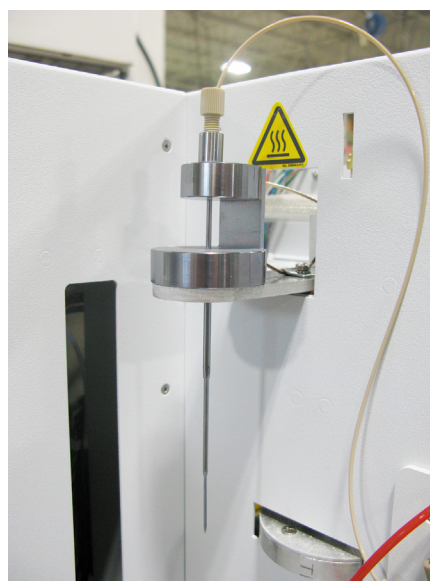

### 1.5.7 XYZ Autosampler Pick and Place Assembly

The XYZ autosampler is an electronically controlled robotic arm that picks up the sample vial using a gripper assembly and then transports it to the sample vial cup of the elevator assembly for sampling. The arm moves in the X, Y, and Z axis allowing access to any of the 84 sample positions.



#### NOTE

The gripper is a pneumatic device and requires the instrument to be connected to the sample gas to function. If the gripper is not functioning correctly, first ensure the sample gas supply is on, properly connected, and supplying 65 - 100 psi (4.48 bar - 6.89 bar) to the Atomx XYZ.

### 1.5.8 Elevator

The elevator moves from the down position where the vial is loaded, to the up position where the vial is pierced by the 3-stage needle for sampling. Once sampling is completed, a stripper bar pulls the vial from the needle as the elevator returns to the down position. The vial is then retrieved by the XYZ autosampler arm and returned to its original position in the autosampler vial rack. Once the vial is removed, the elevator returns to the up position and the needle is rinsed via the drain tubing connected to the sample vial cup. The cup is also equipped with a sample heater for analyzing solid samples using the purge in vial technique.

Figure 1-7 Elevator and Sample Vial Cup

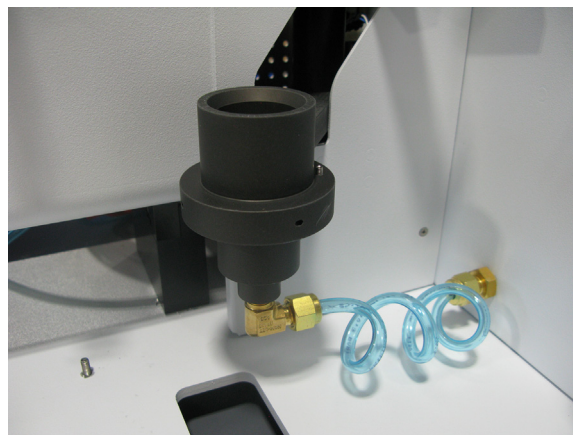
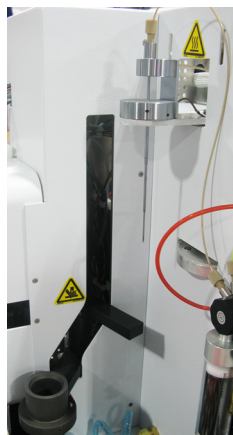

### 1.5.9 Vial Mixer Assembly

The Atomx XYZ mixer assembly allows for a magnetic stir bar (“pill” shape recommended) to be added to a solid sample vial. A rotating magnet located beside the sampling position spins the stir bar and mixes the soil sample (or soil sample with methanol extraction) during the purge process. The mixer has four selectable speeds: slow, medium, high, and agitate (back and forth).

Figure 1-8 Vial Mixer

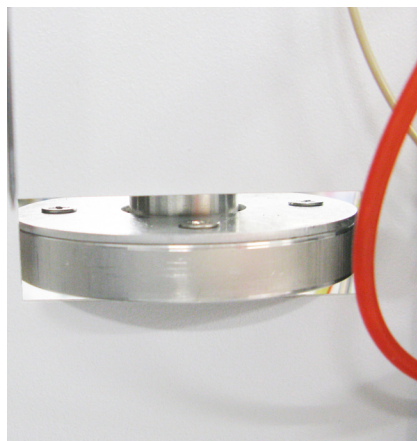

### 1.5.10 Status Light

The Atomx XYZ logo changes color to indicate the instrument’s state. The status related to each color is shown in Table 1-17 "Status Light Indications". The Atomx XYZ logo is lit using an LED board behind the panel.

Table 1-17 Status Light Indications	
Color	Indication
Blue	Standby
Green	Schedule Running
Red	Error

Figure 1-9 Unit Status Light





### 1.5.11 Sample Purge Gas Inlet

Sample gas (ultra-high purity [99.999%] helium or nitrogen) flows through the sparger carrying VOCs to the analytical trap. Nitrogen can be used as sample gas, but it may contain more impurities. The helium or nitrogen enters the back panel through the blue 1/8" (0.32 cm) tubing labeled "Sample Gas". The sample gas is also used for the Dry Purge and Bake Modes.



#### NOTE

Teledyne Tekmar recommends a sample gas flow of 40 mL/min  $\pm$ 5 mL for 11 minutes to achieve a 440 mL purge volume.



#### NOTE

To use nitrogen as the sample gas, the Mass Flow Controller will need to be configured for nitrogen gas on the Configuration Screen in Atomx XYZ TekLink.

### 1.5.12 Mass Flow Controller (MFC)

The Atomx XYZ incorporates a patented mass flow controller to monitor and control the gas flow rates throughout the entire purge and trap process. Once set, the parameters remain precisely controlled throughout all modes of operation and achieve highly repeatable analyses. Flow rates are set via the Atomx XYZ TekLink software.

Figure 1-10 Mass Flow Controller



### 1.5.13 Sample Pathway

When dealing with active, polar, and high-boiling compounds, it is imperative to keep the sample contained in an inert sample pathway. The Atomx XYZ utilizes inert tubing and treated fittings throughout the sample path. This ensures resistance to corrosion and prevents loss of compounds.

### 1.5.14 Analytical Trap

The analytical trap is used to capture and release VOCs swept out of the sample by the purge gas. Once VOCs are captured, the trap is heated causing the VOCs to desorb. The trap is then back-flushed with carrier gas carrying the VOCs to the GC for analysis. The analytical trap is heated using a heating jacket which surrounds it and cooled by a fan at the right of the analytical trap compartment. The temperature of the trap is verified by a Resistance Temperature Detector (RTD) inside the trap heating jacket. The trap compartment door is equipped with a magnetic switch and must be closed for the system to operate.

Figure 1-11 Atomx XYZ Analytical Trap Compartment

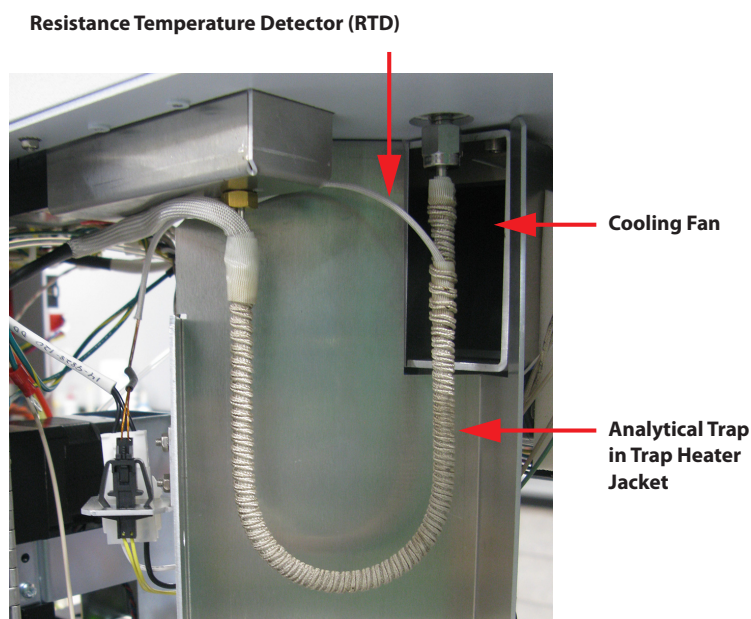

### 1.5.15 Moisture Control System (MCS)

The Moisture Control System (MCS) is located before the inlet to the analytical trap. The MCS block contains a cartridge heater and a Resistance Temperature Detector (RTD) for heating to temperature set-points. The MCS is typically cooled during the Purge Mode to ensure that the MCS is cool during the Desorb Mode. This allows water to be condensed, prior to introduction to the GC column. The MCS is then heated during the Bake Mode to remove any water condensed during the Desorb Mode.



#### NOTE

The MCS may be configured to remain hot during all modes to effectively bypass any moisture removal.



Figure 1-12 Moisture Control System

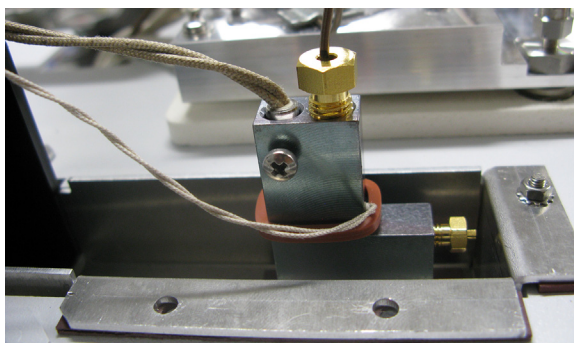

### 1.5.16 Carrier Gas Inlet Line/Heated Sample Transfer Line

The carrier gas inlet line is the inert tubing that runs down the side of the heated sample transfer line from the GC. Carrier gas is used to desorb VOCs off the analytical trap and carry them through the sample transfer line to the GC.

The sample transfer line is the inert piece of tubing that runs down the center of the transfer line heater to ensure the VOCs being transferred to the GC column stay in their gaseous state. Carrier gas makes a passive loop through the Atomx XYZ and returns, unchanged, to the GC through the transfer line. GC carrier gas is independently controlled through the GC or an External Pressure Control (EPC).

Figure 1-13 Carrier Gas Inlet Line and Heated Sample Transfer Line

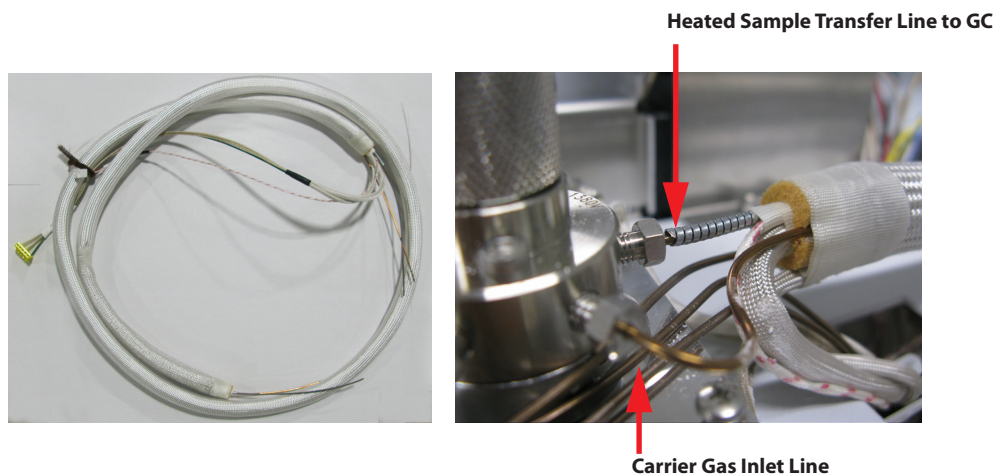

## 1.5.17 Valving

The Atomx XYZ contains the valves shown in Table 1-18 "Valve Overview". The internal standard pressure regulator is also located on the valve manifold.

Table 1-18 Valve Overview	
Solenoid Valves	9 (standard configuration) or 11 (optional Guardian Foam Eliminator configuration) 24 VDC rocker style valves
Soil Valve	On/Off heated solenoid, 24 VDC
6-Port Valve	2-position, heated 6-port valve actuated with a 24 VDC motor with encoder feedback
6-Port Syringe Valve	A multi-port selection valve mounted to the top of the syringe
Standard Addition Valves	Three 24 VDC dosing valves

### Solenoid Valves

Figure 1-14 Atomx XYZ Valve Manifold (Valves Mounted Underneath)

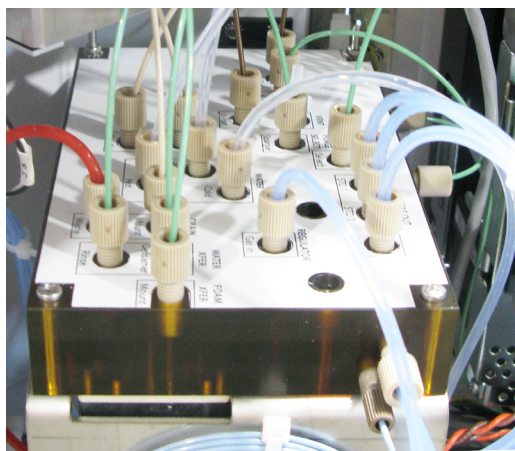

The manifold contains the following valves:

- Purge Valve (a)
- Bake Valve (b)
- Vent Valve (c)
- Drain Valve (d)
- Purge Select Valve (e)
- Syringe Valve (g)<sup>1</sup>
- Liquid Transfer Valve (h)
- Pressurize Valve (i)<sup>2</sup>
- Foam Transfer Valve (Optional) (j)
- Water Transfer Valve (Optional) (k)
- Water Valve (l)
- Three Internal Standard Valves<sup>3</sup>
  1. Valve "f" is the soil valve and is located behind the sample needle.
  2. Valve is mounted on the side of the manifold.
  3. Valves are mounted beneath the manifold with no visible ports and controlled by the Internal Standard Valve Control Board.

### Heated 6-Port Valve

The 6-Port valve is a two-position valve that routes the purge and trap concentrator flows according to each mode of operation. The valve is located in the “valve oven” that heats the valve to a set temperature.

Figure 1-15 Heated 6-Port Valve

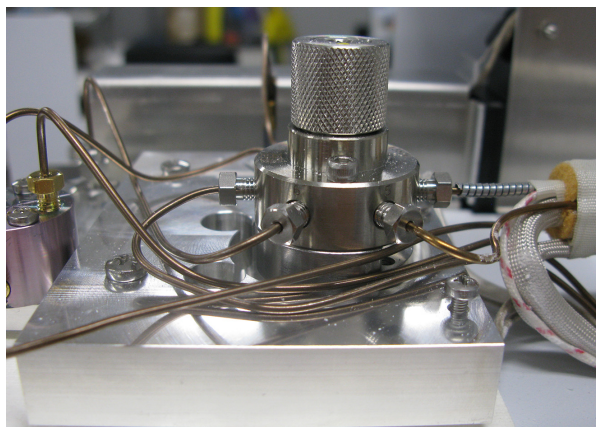

### Heated Soil Valve

The soil valve is an On/Off heated 24VDC solenoid used for solid (soil) samples purged in the vial (with or without methanol extraction).

Figure 1-16 Soil Valve

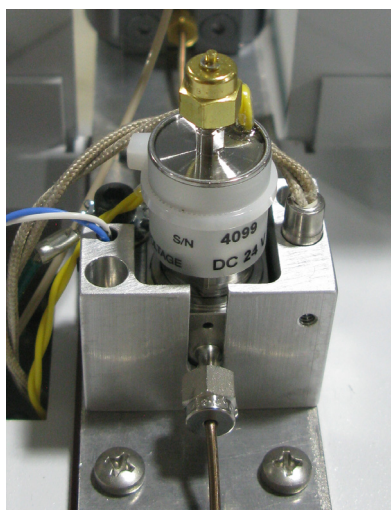

## 6-Port Syringe Valve

The 6-port syringe valve is a multi-port selection valve which allows for liquids to be drawn into the syringe such as hot or cold water, methanol, and water from sample vials. This valve can then be used to select where to dispense the contents of the syringe including the sample glassware, the needle, or to waste. Gas flow entering the side port of the syringe can also be distributed to these same destinations through the 6-port valve.

Figure 1-17 6-Port Syringe Valve

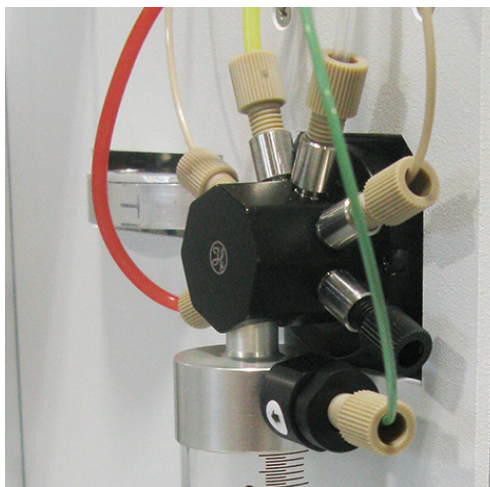

## 1.6 Optional Accessories

### 1.6.1 Sparge Vessel Heater

The sparge vessel heater assembly for all glassware types heats the sparger glassware to method parameters as defined on the TekLink software's METHODS TAB. The heater assembly consists of a heater jacket with Resistance Temperature Detector (RTD) that is slid over the sample glassware. The heater is capable of heating the sparger from 35-100 °C.

Figure 1-18 Sparge Vessel Heater



## 1.6.2 Vial Chiller Plate

The Atomx XYZ can be equipped with an optional chilling plate (installed beneath the autosampler vial rack) that allows sample vials to be held at temperatures down to 4° C until they are sampled. The vial chiller requires connected to a recirculating bath (not supplied).

Figure 1-19 Vial Chiller Plate

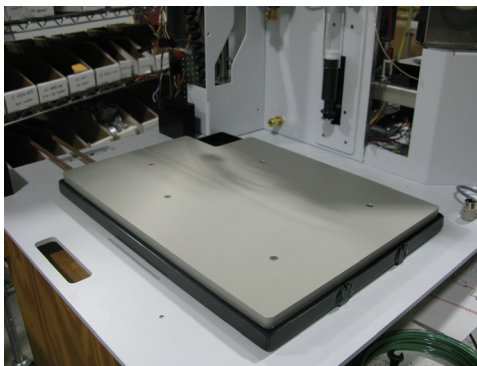

## 1.6.3 Guardian Foam Sensor and Eliminator

The Atomx XYZ can be equipped with an optional foam sensing and eliminating system to safeguard the Atomx XYZ from the adverse effects of liquid entering the gas pathway. The Atomx XYZ can be equipped with only the foam sensor to trigger an alert or the sensor and eliminator to trigger an alert, remove the foam from the sample, and rerun. This safeguard monitoring takes place automatically, allowing overnight or extended runs. For more information refer to Section 2.11 "Guardian Foam Sensor and Foam Eliminator (Optional)".

Figure 1-20 Guardian Foam Sensor and Foam Eliminator/Rinse Vessels

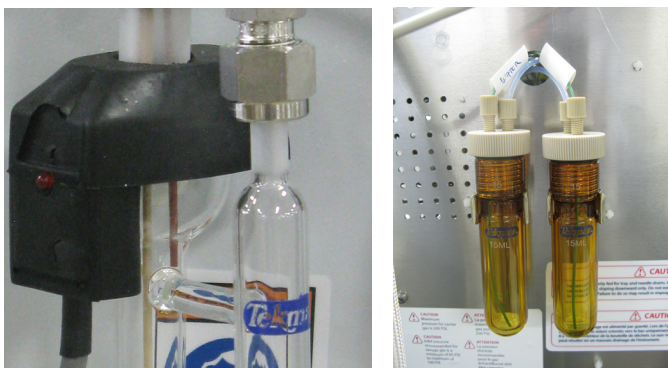



# Atomx XYZ User Manual

## Chapter 2: Installation and Setup

### 2.1 Pre-Installation

#### 2.1.1 Overview

This chapter contains information on:

- Pre-installation requirements including electric, gas and software/computer.
- Unpacking the system and checking for shipping damage and/or missing items.
- System overview including primary parts and components.
- Installation procedures including gas, electrical, liquid, data, and GC connection.
- Optional vial chiller tubing Connections.
- Atomx XYZ TekLink software installation and creation of an instrument profile.
- Configuration of the optional Guardian Foam Sensor and Eliminator in the Atomx XYZ TekLink software.
- Required grade of methanol for methanol rinse and extraction.
- Preparation of DI water and internal standards.



#### NOTE

Use Section 2.5 "Atomx XYZ System Overview" to identify and locate the components described in the installation procedures.

#### 2.1.2 Operating Environment

The Atomx XYZ operates at temperatures between 10 °C and 30 °C (50 °F and 86 °F) with humidity levels between 10% and 90%. These temperatures and humidity levels are consistent with a standard lab environment and should pose no difficulty.



#### NOTE

To avoid material and/or component damage keep the Atomx XYZ away from corrosive substances.

### 2.1.3 Work Surface Requirements

The Atomx XYZ is 19.5" (49.5 cm) high, 27.6" (70.1 cm) wide, 23" (58.4 cm) deep, and weighs 95 lbs (43.09 kg).



#### Caution

The Atomx XYZ weighs 95 lbs (43.2 kg). If this weight exceeds your lifting ability, lift and position the Atomx XYZ with two people. Only lift and position the Atomx XYZ using the designated lift points.

Make sure the surface where you place the Atomx XYZ is capable of supporting the unit's weight, has a clear surface area with no shelves or overhanging obstruction, and allows the unit to sit firmly and evenly on the surface.



#### WARNING

**To avoid the risk of fire and maintain optimum instrument performance, install the Atomx XYZ on a non-flammable surface and maintain a minimum 6" (15.24 cm) perimeter around the unit that is unobstructed by flammable material or other equipment.**



#### WARNING

**Ensure that the installation location allows the Atomx XYZ to be easily turned off and the power cord disconnected, in the event of an emergency.**

### 2.1.4 Electrical Requirements

After selecting a location for the Atomx XYZ, check the availability of the required grounded outlets. The Atomx XYZ requires:

- 100-120 VAC +/- 10%, 50/60Hz, 10.0A, 1150W or 220-240 VAC +/- 10%, 50/60Hz, 5.0A, 1150W.
- One grounded, three-pronged receptacle for the main power cord.



#### WARNING

**The circuit used to power the Atomx XYZ should be protected by a Certified/Listed 15/20 Circuit Breaker for short circuit protection.**



#### NOTE

Additional accessories may also require one or more grounded outlets.



## 2.1.5 Gas Supply Requirements

The Atomx XYZ requires two independent gas flows:

1. Sample Purge Gas of ultra high-purity nitrogen or helium.
2. Carrier Gas supplied from the GC or carrier gas source.

Verify that the following requirements are met:

1. Nitrogen or helium purity must be 99.999% and < 0.5 ppm hydrocarbon tested.
2. Gas pressure at the source must be high enough to:
  - Allow at least a 65 psi (4.48 bar) pressure drop at every flow or pressure regulator.
  - Travel the distance from the source to the Atomx XYZ
  - Provide the required gas pressure at the unit. Operation of the Atomx XYZ requires helium or nitrogen at an incoming (supply) pressure of 65 - 100 psi (4.48 - 6.89 bar)
3. The diameter of the tubing that supplies the gas depends on the maximum pressure drop allowable for the configuration.
  - If the helium supply is close to the Atomx XYZ, use the pre-installed blue 1/8" (0.32 cm) tubing.
  - If the gas supply is a significant distance from the Atomx XYZ, a single source supplies several instruments, or a single source is subject to high demand for gas, you may want to reduce pressure by replacing the supply line from the gas source with 1/4" tubing.
4. Gas supply tubing lengths must be adequate. Be generous when cutting lengths of tubing for local supply lines. A relatively long coil of tubing between the supply and the Atomx XYZ allows you to move the instrument without disconnecting the plumbing. The system is supplied with 6 ft (1.82 m) of tubing. Additional tubing can be added to increase the length as needed.
5. It is essential that gas line fittings and regulators are the correct size and type. Consult your local gas supplier for type and size of cylinder valves, and then select compatible pressure regulators based on the required valves. Keep these considerations in mind:
  - Use quality pressure regulators with stainless steel diaphragms. This reduces the high source pressure at the tank to levels required by the Atomx XYZ.



### NOTE

Teledyne Tekmar recommends using a single, two-stage regulator rather than two single-stage pressure regulators.

- ON/OFF valves, while not essential, are very useful when mounted on the outlet fitting of a two-stage regulator.
- If pipe thread connections are required in your gas supply lines, seal them with instrument-grade PTFE tape.



### NOTE

Always use instrument-grade PTFE tape to seal thread connections. Do not use pipe dope or lower grades of PTFE tape. Volatile materials in the dope and/or low-grade tape will contaminate the tubing.

## 2.1.6 Minimum Computer Requirements

Connect the Atomx XYZ to a computer that meets or exceeds the specifications shown in Table 2-1 "Minimum Computer Requirements":

<b>Table 2-1 Minimum Computer Requirements</b>	
<b>Component</b>	<b>Specification</b>
Processor	300 MHz Pentium II (Or Equivalent)
Memory	512 MB
Hard Drive Space	6.4 MB
Display	VGA
Drive	4x CD-ROM
Operating System	PC Interface through Windows® 7 or higher. Windows® 10 is recommended.
Input	Mouse
Devices	Compatible speakers and sound system

## 2.2 Required Tools and Supplies for Installation and Operation

The following tools and supplies will be required for the installation of the Atomx XYZ:

- Tubing cutters
- 3/8" Open-ended wrench (if changing the standard #9 trap)
- 7/16" Open-ended wrenches (2)
- 5/16" Open-ended wrenches (2)
- Phillips-head screwdriver
- Waste container (not supplied with the Atomx XYZ)
- Ultra-Pure helium or nitrogen supply, regulated to 65 -100 psi (4.48 bar -6.89 bar) prior to the Atomx XYZ
- Carrier gas regulator if not connecting to regulated GC carrier gas supply
- Gastight® syringes (10 µL)
- Volumetric flasks
- Purge and Trap (P&T) grade methanol
- VOC Standards
- GC I/O Cable (must be ordered separately). Refer to Section 5.4 "GC In/Out (I/O) Cable and GC Type Reference".
- Recirculating bath for optional vial chiller configuration
- Anti-foam solution (included) for optional Guardian Foam Sensor and Eliminator configurations

## 2.3 Unpacking the Atomx XYZ



The Atomx XYZ weighs 95 lbs (43.1 kg). If this weight exceeds your lifting ability, lift and position the Atomx XYZ with two people. When lifting the Atomx XYZ, use the designated lift points.

Unpack the Atomx XYZ, Installation Kit Box, optional components and accessories, and then inspect the contents against the packing list.

If there are any damaged or missing items contact Teledyne Tekmar Customer Support, using the information in Section P.2 "Teledyne Tekmar Customer Support Center", immediately. Claims for loss of a package or shipping damage should be promptly filed with the carrier.

## 2.4 Installation Kit Box

The Atomx XYZ is provided with an Installation Kit Box that contains parts for completing the installation. Throughout the installation procedure obtain parts from the Installation Kit Box, when necessary.

Figure 2-1 Installation Kit Box Label

Washer, Teflon, 14-7201-009 (3)	Nut, Plug, 1/16", Brass 14-2792-016 (1)	 <b>TELEDYNE TEKMAR</b> Everywheretheyoulook™  (800) 874-2004 (513) 229-7000 www.teledynetekmar.com		Plug Nut, 1/4-28, TEFZEL, Flat Bottom 14-8470-016 (1)	P/N: 15-3200-KIT Rev.A  Bushing, Exit, 1/8", TEFZEL, Short 14-7038-016 (1)
Ferrule, 1/16", SS 14-0241-016 (1)	Nut, 1/16", Short, Gold Plated 14-0243-116 (1)	Ferrule, 1/2" Set, Teflon 14-1301-016 (1)	Nut, Male Plug, 1/16", Gold Plated 14-1590-116 (1)	Calibration Tools 15-3615-079 (1) 15-3616-079 (1)	
Ferrule, 1/16", PEEK, Super Flangeless 14-7671-016 (1)	Nut, PEEK, Natural, for 1/16" OD Tubing 14-7695-016 (1)	Ferrule, 1/8" Vespel 15-0285-016 (2)	Nut, 1/8", SS, Valco, Gold Plated 14-4602-116 (1)	Tee, 1/8", Brass 12-0070-016 (1)	Nut, 1/8", PEEK, 1/4-28, Long 14-9778-016 (1)
Union, 1/16 - 1/16 SS 14-0051-016 (1)	Fuse, 10 Amp, (115 VAC Only) 14-5180-034 (2)	Fuse, 5 Amp, (230 VAC Only) 14-5665-034 (2)	Cap Fuse, 2 Amp 14-9432-034 (1)	Cap Fuse, 3.15 Amp 14-9433-034 (1)	Cap Fuse, 5 Amp 14-9434-034 (1)

## 2.5 Atomx XYZ System Overview

Figure 2-2 Front of Atomx XYZ

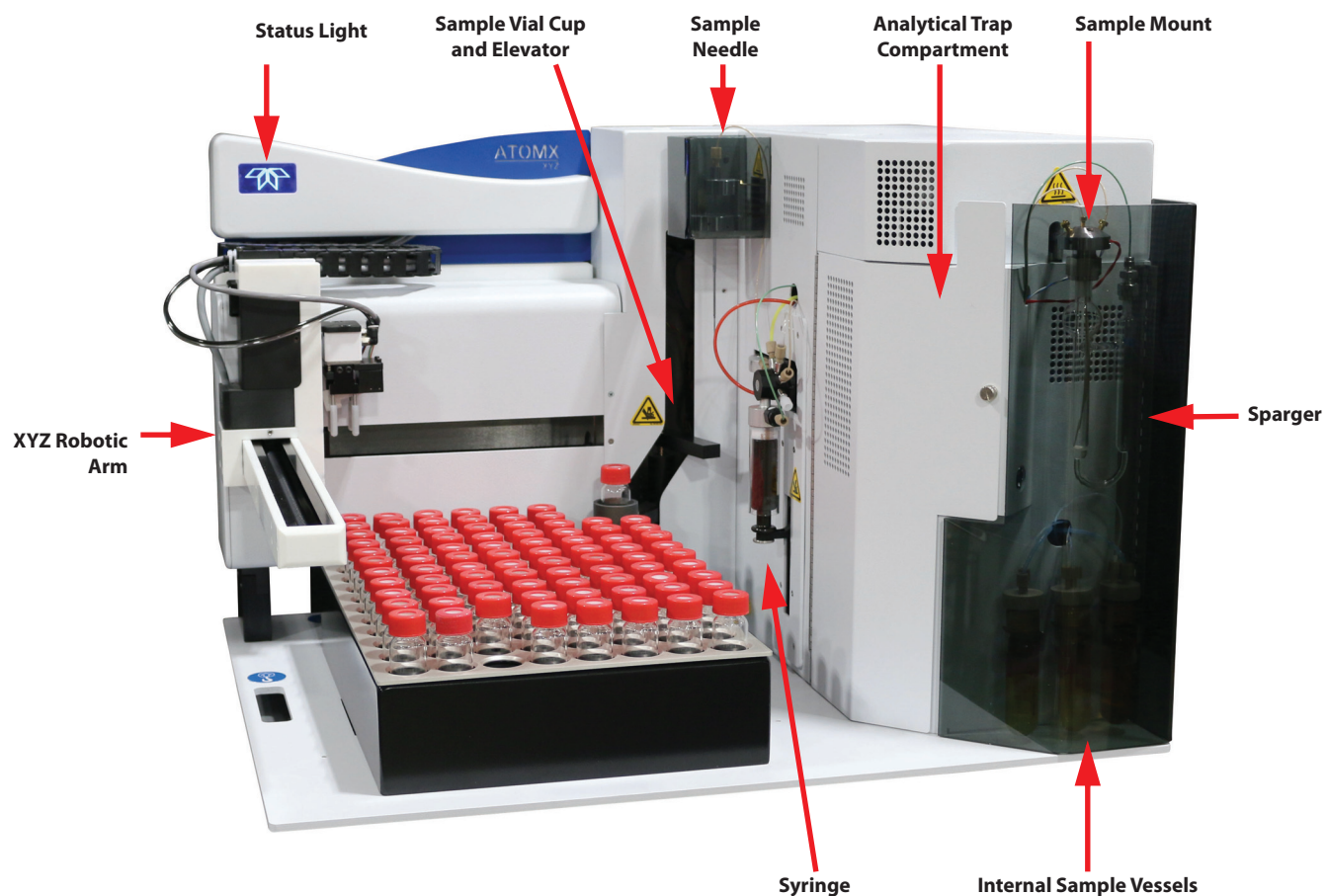
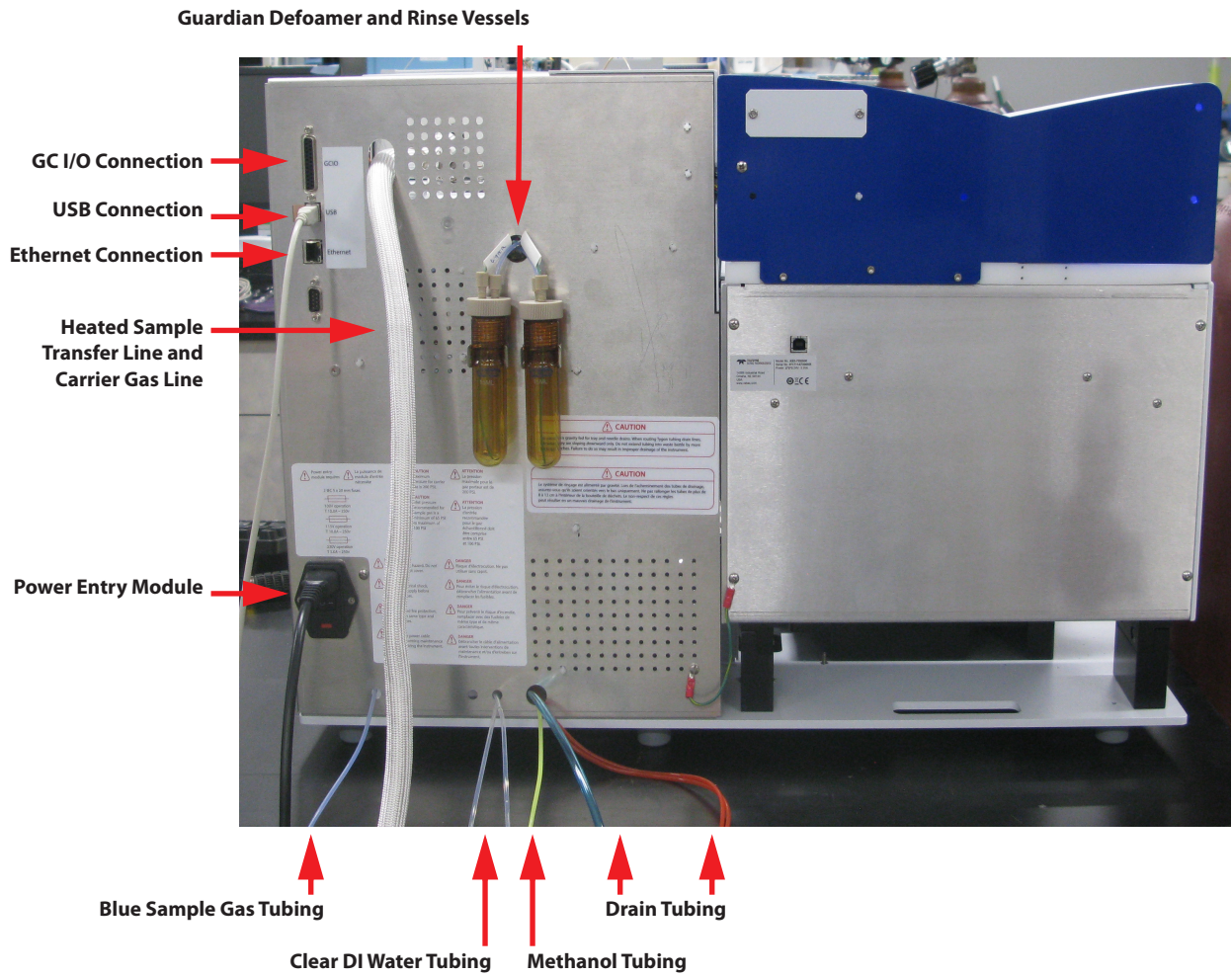

Figure 2-3 Back of Atomx XYZ



## 2.6 Electrical and Data Connections

### 2.6.1 AC Power Cord



#### NOTE

For electrical requirements refer to Section 2.1.4 "Electrical Requirements".

1. Ensure the switch on the Power Entry Module (PEM) is in the OFF (O) position.
2. Plug the AC power cord into the PEM and connect it to a properly rated and grounded AC receptacle.



#### WARNING

The circuit used to power the Atomx XYZ should be protected by a Certified/Listed 15/20 Circuit Breaker for short circuit protection.



#### WARNING

Ensure the power cable is routed away from, and is not capable of contacting, any hot surface.

Figure 2-4 Atomx XYZ Power Entry Module





## 2.6.2 GC I/O (Input/Output) Connection



### NOTE

Refer to Section 5.4 "GC In/Out (I/O) Cable and GC Type Reference" to determine what cable should be used.

1. Connect the GC I/O cable to the gas chromatograph according to the GC instructions.
2. Connect the GC I/O cable to the GC I/O port on the back of the Atomx XYZ.
3. Once connected, communication to the GC will be configured via the TOOLS>CONFIGURATION SCREEN in Atomx XYZ TekLink software later in the installation procedure. Refer to Section 2.10 "Create an Instrument Profile".

Figure 2-5 GC I/O Cable Connection

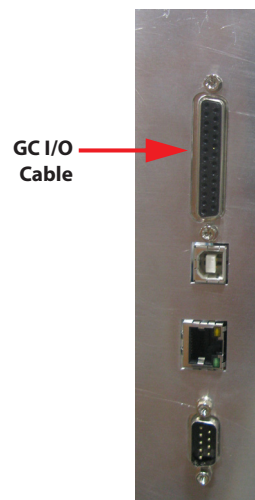



## 2.7 Gas Connections

### 2.7.1 Connecting the Atomx XYZ Sample Purge Gas Supply



#### NOTE

For sample gas requirements refer to Section 2.1.5 "Gas Supply Requirements".

The blue 1/8" (0.32 cm) tubing labeled "Sample Gas" (Figure 2-6) is used to connect to the laboratory helium or nitrogen supply line as shown in Figure 2-8. The sample purge gas is used during Purge Mode to strip VOCs from the sample and deposit them on the analytical trap, as well as during Bake Mode to clean the analytical trap between samples.



#### NOTE

Atomx XYZ sample purge gas is usually supplied through a tee union from the main laboratory helium or nitrogen supply.

1. Connect a 1/8" Swagelok® brass tee (found in the Installation Kit Box) to the laboratory helium or nitrogen supply line.
2. Route the blue 1/8" (0.32 cm) sample purge gas tubing from the Atomx XYZ to the tee and connect. Insert the tubing into the union, and then tighten with a 7/16" wrench.



#### WARNING

**Ensure the sample gas line is not within 10" of any heated components.**

Figure 2-6 Sample Purge Gas Tubing

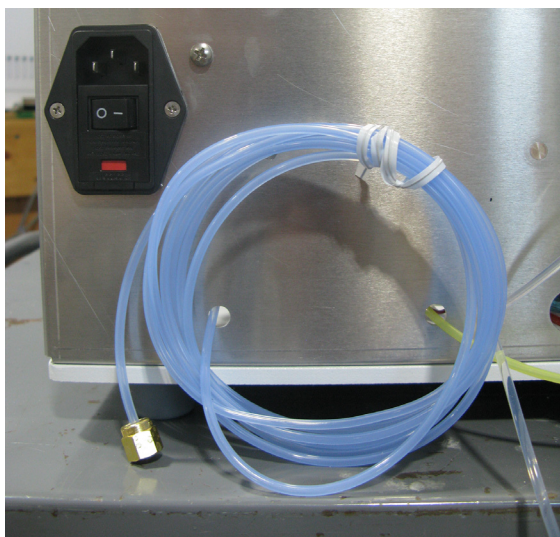

## 2.7.2 Atomx XYZ Carrier Gas Supply and Heated Sample Transfer Line Connection to the Gas Chromatograph (GC)

Figure 2-7 Atomx XYZ Carrier Gas Line /Heated Sample Transfer Line

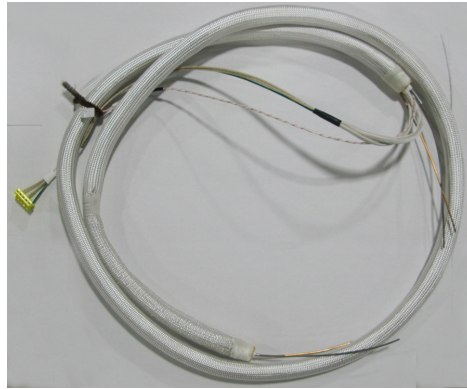

The Atomx XYZ connects to the regulated carrier gas of the GC at a location after the GC Electronic Pressure Control (EPC) and prior to the GC injection port. By connecting at this location, the GC regulated carrier gas is routed through the Atomx XYZ to carry desorbed VOCs from the analytical trap back to the GC sample inlet. This typically requires cutting the GC tubing and making two connections to the Atomx XYZ carrier gas line/heated sample transfer line. How the connections are made can vary according to gas supply and GC manufacturer. Follow the procedures below, as well as referencing the GC User Manual.

Figure 2-8 Atomx Carrier Gas Line, Heated Sample Transfer Line and Purge Gas Tubing Connections

### Standard Configuration: GC Injection Port Interface GC Regulated Carrier Gas

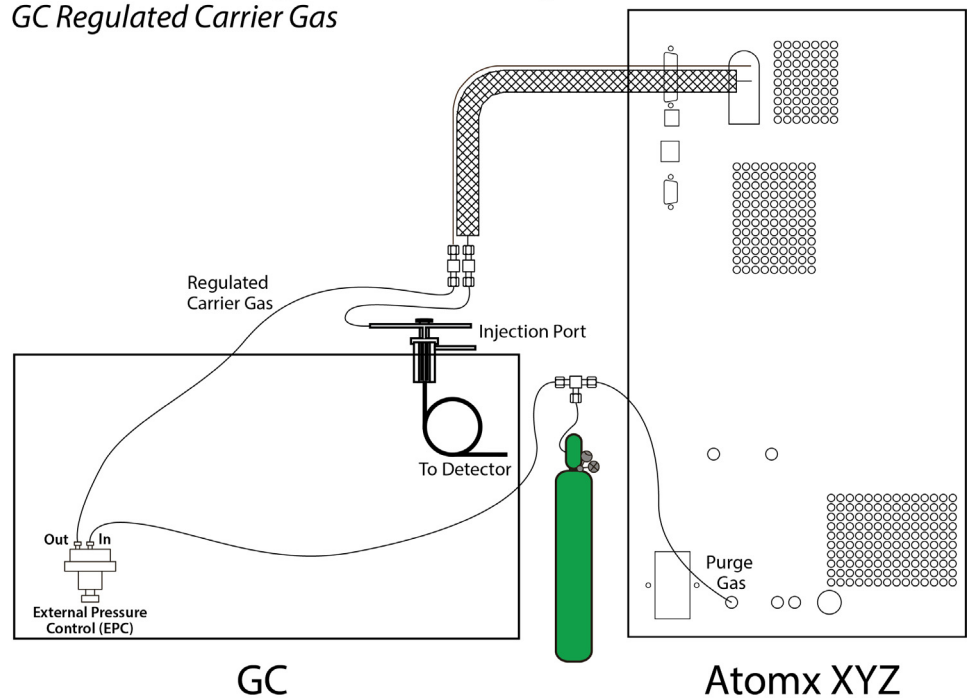



**Warning! Hot surface! Allow the GC injection port to cool prior to performing this procedure.**

1. Route the GC carrier gas line/heated sample transfer line from the Atomx XYZ to the GC.



### WARNING

**Ensure there is at least 10" of clearance between the heated jacket of the sample transfer line and any other object.**

2. Power off the GC. Select an injection port on the GC. Remove any covers around the GC injection port to expose the regulated carrier gas line that connects to the injection port.



### NOTE

Some injection ports have multiple tubing connections. Do not cut any lines until you are certain which one is the regulated carrier gas line going to the injection port.

3. Prepare to connect the Atomx XYZ carrier gas line and heated sample transfer line using Swagelok unions according to one of the following scenarios:
  - If a union connects the tubing from the GC EPC to the GC injection port, disconnect one side of the existing union and remove the tubing. Install an additional 1/16" Swagelok union (from the Installation Kit Box) on the removed tubing. Insert the tubing into the union and then tighten using one 5/16" wrench to hold the center of the union and another to tighten the nut.
  - If there is no union, cut the tubing from the GC EPC approximately one inch from the GC injection port and install two 1/16" Swagelok unions (from the Installation Kit Box) on each of the tubing lines. Insert the tubing into the union and then tighten using one 5/16" wrench to hold the center of the union and another to tighten the nut.
4. Connect the Atomx XYZ carrier gas line (outside tubing) to the union on the tubing from the GC Electronic Pressure Control (EPC). Connect the union to the tubing in the same manner as previous procedures.
5. Connect the Atomx XYZ heated sample transfer line (inside center tubing) to the tubing going to the GC injection port. Connect the union to the tubing in the same manner as previous procedures.

## 2.8 Liquid Connections

### 2.8.1 Drain Tubing

Run the two red 1/8" (0.32 cm) and single blue 1/4" (0.64 cm) drain tubing lines (Figure 2-9) to a sink or waste bottle. If a vial chilling plate is installed, also route the clear 1/2" (1.27 cm) wire re-enforced tubing to the waste container. Make sure the drain tubing is not crimped or blocked in any way. Because the drain is gravity fed, ensure that the drain lines do not include any loops, and are lower than the Atomx XYZ.

Figure 2-9 Drain Tubing

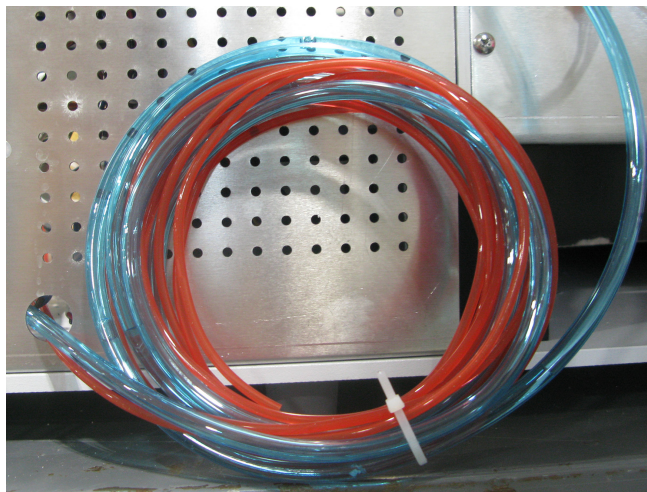

### 2.8.2 DI Water Reservoir Connection



#### NOTE

For information on preparing DI Water, refer to Section 2.12 "Preparing DI Water".

The Atomx XYZ requires a source of DI water for system rinsing, auto-blanks and dilutions. The Atomx XYZ is supplied with a 10 L reservoir for the DI water supply. To avoid contamination problems, use blank (organic-free) water. Follow the instructions below to supply the instrument with DI water:

1. Fill the supplied 10 L reservoir with DI water.
2. Insert the two clear 1/8" (0.32 cm) water supply lines (Figure 2-10) with weights through the top of the 10 L reservoir and allow the lines to rest at the bottom of the reservoir.
3. Place the reservoir as close to the unit as possible and above or level to the Atomx XYZ.
4. To prime the DI water supply lines, refer to the Section 3.6.1 "Prime Menu".



## NOTE

Do not locate the water reservoir more than 4 ft (1.22 m) below the Atomx XYZ unit. Height differentials larger than 4 ft (1.22 m) can cause damage to the syringe due to siphoning.

Figure 2-10 DI Water Tubing (Weights Not Shown)



### 2.8.3 Optional Methanol Reservoir Connection

The Atomx XYZ can be equipped with a methanol reservoir (no supplied) for methanol rinsing and the automated analysis of high-level solids via methanol extraction and subsequent dilution. Follow the instructions below to supply the instrument with methanol.



## NOTE

Teledyne Tekmar recommends using a 4 L bottle of purge and trap grade methanol.

1. Insert the yellow 1/8" (0.32 cm) methanol supply tubing (Figure 2-11) into a methanol supply vessel.
2. Place the supply as close to the unit as possible and above or level with the Atomx XYZ.
3. To prime the methanol supply lines refer to the Section 3.6.1 "Prime Menu".



## NOTE

Do not locate the methanol reservoir more than 4 ft (1.22 m) below the Atomx XYZ unit. Height differentials larger than 4 ft (1.22 m) can cause damage to the syringe due to siphoning.



Figure 2-11 Methanol Supply Tubing



#### 2.8.4 Optional Vial Chiller Plate Tubing Connections

If the instrument configuration includes vial chilling, connect the Atomx XYZ chiller plate to a user supplied recirculating bath. Inlet and outlet hose connections require 1/4" (0.64 cm) ID rubber tubing.

1. Connect the coolant lines from the recirculating bath to the chiller plate lines according to customer preference and/or the recirculating bath instructions. The connection may be made using Swagelok® fittings or hose clamps.
2. Once connected, ensure the entire length of the cooling lines are covered with insulation.

Figure 2-12 Recirculating Bath Connection to Vial Chiller Tray

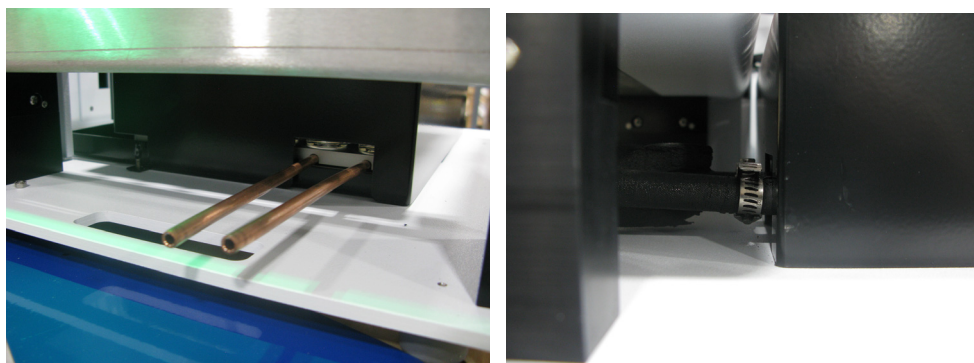

## 2.9 Install Atomx XYZ TekLink Software



### NOTE

For computer requirements refer to Section 2.1.6 "Minimum Computer Requirements".

1. Ensure the controlling computer is not connected to the Atomx XYZ via USB cable.
2. Power on the controlling computer.
3. Insert the Atomx XYZ TekLink Software Installation CD into the computer's disc drive. The ATOMX XYZ TEKLINK INSTALLATION MENU will be displayed.
4. Highlight ATOMX XYZ TEKLINK from the installation menu and then select the INSTALL BUTTON.

Figure 2-13 Atomx XYZ Software Install Menu

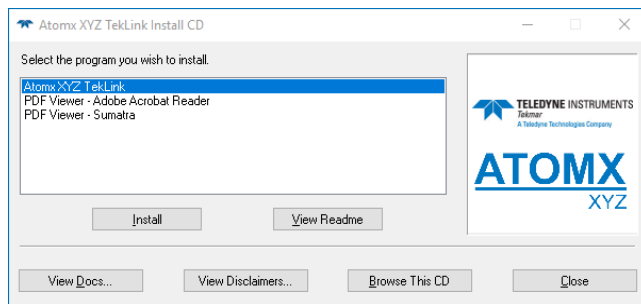

5. The ATOMX XYZ TEKLINK SETUP WIZARD will begin. It is recommended to close all other programs during the software installation. Select the NEXT BUTTON to continue.

Figure 2-14 Atomx XYZ TekLink Installation Wizard

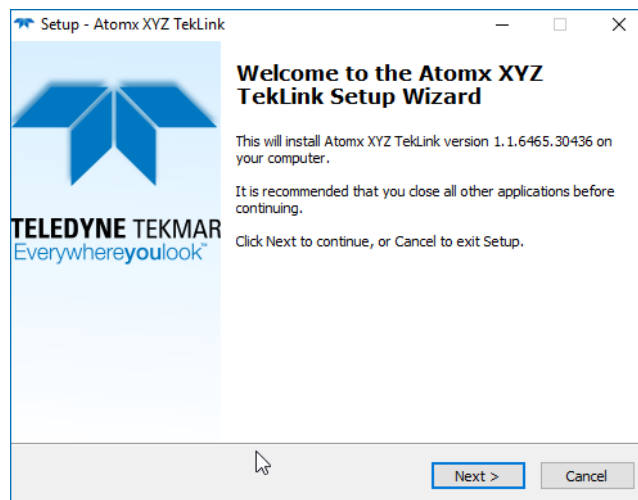



- The RELEASE NOTES will be shown. Review the notes and then select the NEXT BUTTON to continue.

Figure 2-15 Release Notes

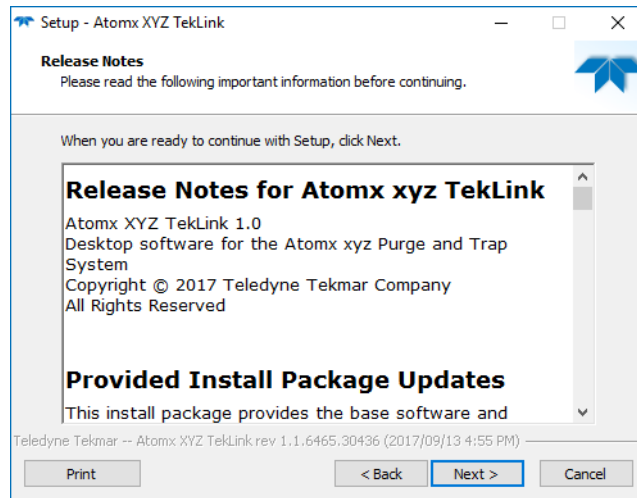

- The LICENSE AGREEMENT will be shown. Review the agreement, and then select the I ACCEPT THE AGREEMENT RADIO BUTTON. Once selected, click the NEXT BUTTON to continue.

Figure 2-16 License Agreement

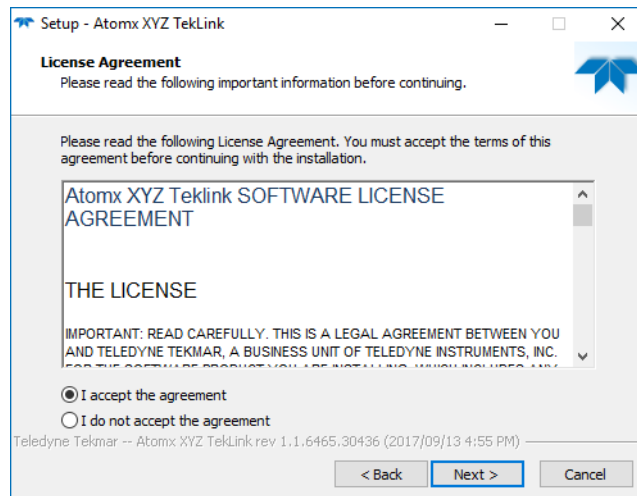

- The wizard will request where to install the software. Use the default software installation location shown or browse to a custom location. Once chosen, select the NEXT BUTTON to continue.

Figure 2-17 Select Destination Location

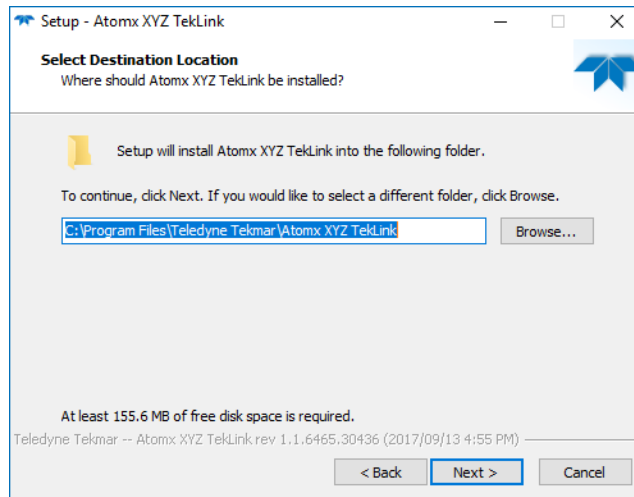

9. The wizard will request what additional components (configuration) to install. Select the components to install from the drop-down menu. Once chosen, select the NEXT BUTTON to continue.

Figure 2-18 Select Components

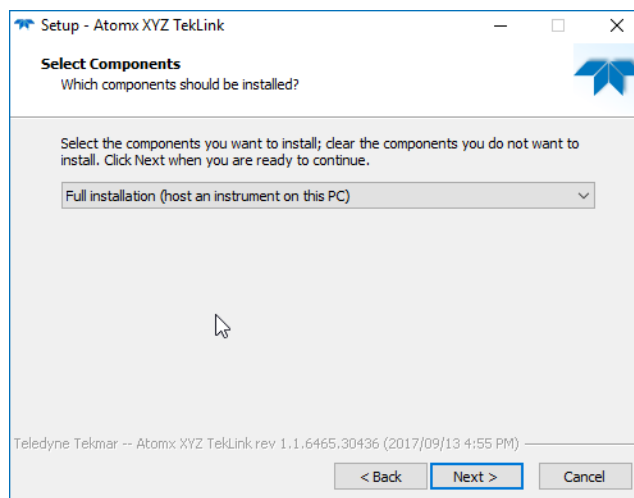

10. The wizard will request in which START MENU FOLDER to place the software shortcut. Use the default location or browse to a custom location for the software shortcut. Once chosen, select the NEXT BUTTON to continue.

Figure 2-19 Select the Start Menu Folder

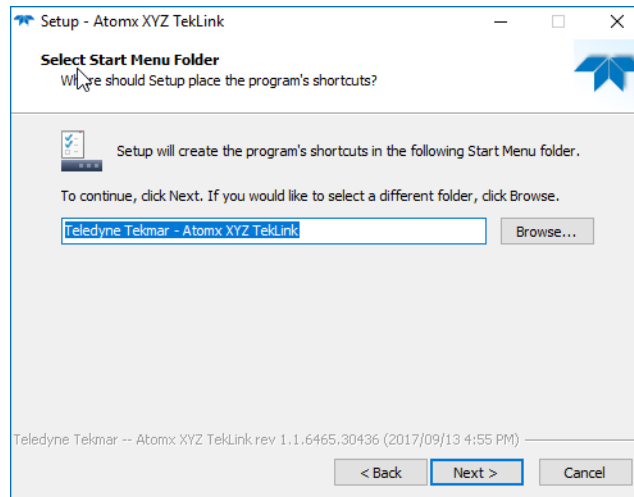

11. The wizard will request what additional tasks should be accomplished during installation. Select if you would like the software icon to be installed on the desktop by placing a check mark beside the selection. Once chosen, select the NEXT BUTTON to continue.

Figure 2-20 Select Additional Tasks

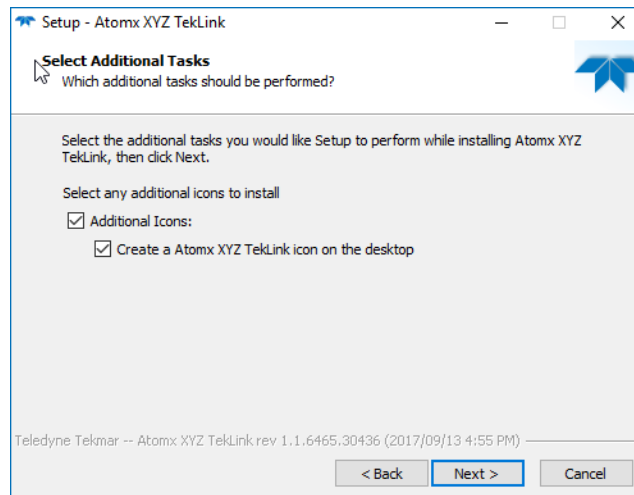

12. The software is now ready to install. Select the **INSTALL BUTTON** to install the software.

Figure 2-21 Ready to Install

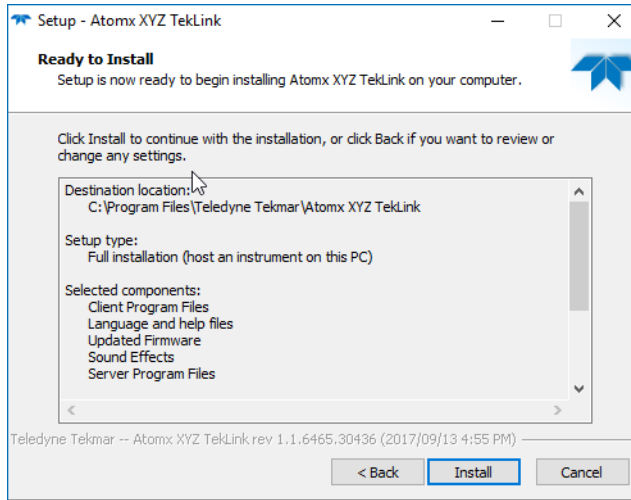

13. The software installation progress will be shown.

Figure 2-22 Installation in Progress

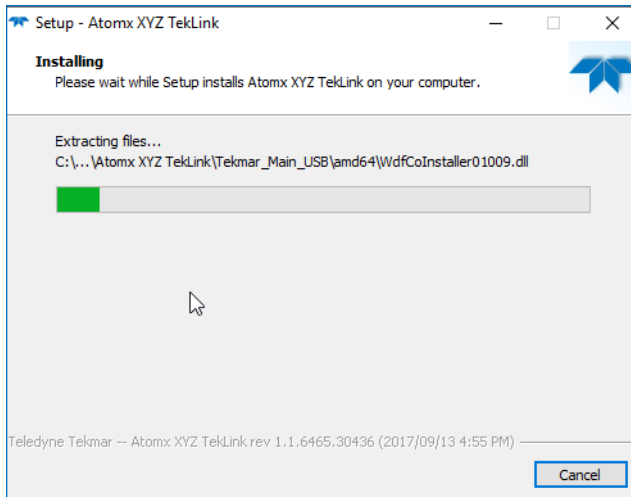

14. If a WINDOWS SECURITY PROMPT is shown, ensure ALWAYS TRUST SOFTWARE FROM “TELEDYNE INSTRUMENTS INC.” is checked, then select the INSTALL BUTTON to continue.

Figure 2-23 Windows Security Prompt

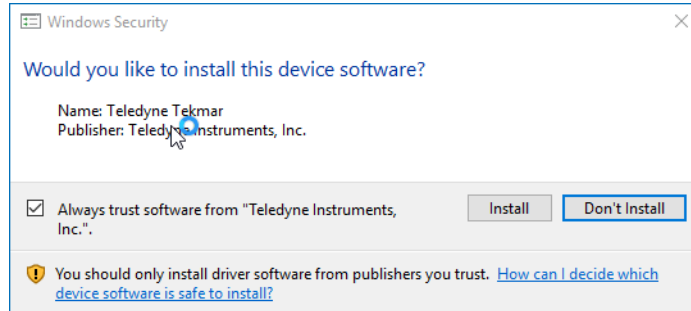

15. Once the software is installed, the COMPLETION SCREEN will be shown. Select the FINISH BUTTON to complete the installation and close the wizard.

Figure 2-24 Software Completion

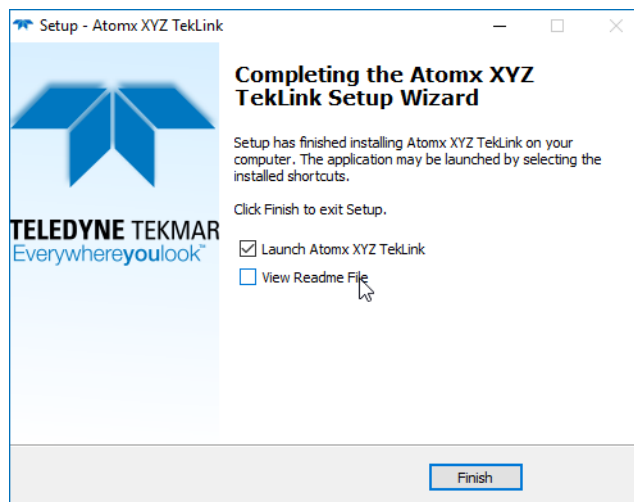

### 2.9.1 Connect the USB Interface Cable

1. Connect the supplied USB cable to the USB port at the back of the Atomx XYZ, then to a USB port on the computer.
2. Power on the Atomx XYZ.

Figure 2-25 Atomx XYZ USB Connection

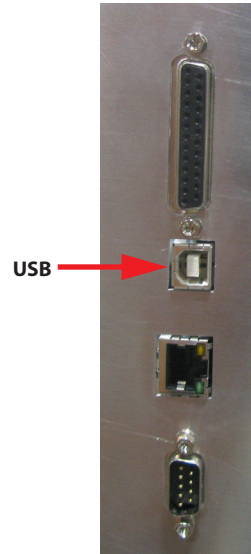

### 2.10 Create an Instrument Profile

Once the Atomx XYZ TekLink software has been installed an instrument profile will need to be created.



#### NOTE

All methods, schedules, and TekLink software configurations/settings are profile specific.

1. If necessary, double-click the software shortcut on the computer desktop to open Atomx XYZ TekLink. When Atomx XYZ TekLink is opened for the first time, a NO DEFAULT INSTRUMENT CONFIGURED NOTIFICATION MESSAGE will be displayed. Clicking the OK BUTTON of the notification will display the CONFIGURATION DIALOG to create a new instrument profile.

The CONFIGURATION DIALOG can also be accessed by selecting TOOLS SCREEN>CONFIGURATION BUTTON. Once selections have been made on the GENERAL, OPTIONS, and LEAK CHECK TABS of the CONFIGURATION DIALOG, select the OK BUTTON to create the instrument profile.

2. On the GENERAL TAB:
  - Enter a NAME for the instrument profile.





## NOTE

If other Atomx XYZ instruments are on the same network, use the name and description to differentiate one instrument from another. This will assist when defining system properties and settings.

- Enter a DESCRIPTION that easily identifies the instrument.

Figure 2-26 Creating an Instrument Profile

- If the computer is connected to multiple instruments, choose the appropriate USB connection from the drop-down menu. All instruments must be connected via USB cable for the connections to be shown.
3. On the OPTIONS TAB:
- If you would like the system to make an audible noise to notify of errors ENABLE BEEPER.
  - If you would like to enable the SAMPLE ID column on the SCHEDULES SCREEN.
  - If an optional Guardian Foam Sensor and/or Eliminator is installed, select ENABLE GUARDIAN FOAM SENSOR. Choose the configuration and action from the drop-down menu.
  - Select the appropriate PURGE GAS from the PURGE GAS DROP-DOWN MENU.
  - Select the CHROMATOGRAPH (GC) TYPE from the GC MODEL DROP-DOWN MENU. If the specific model of the GC is not shown in the drop-down menu, use the STANDARD TYPE:63 or USER TYPE:31 check-box. If necessary, refer to the GC manufacturer's *User Manual* instructions.

Figure 2-27 Options Tab

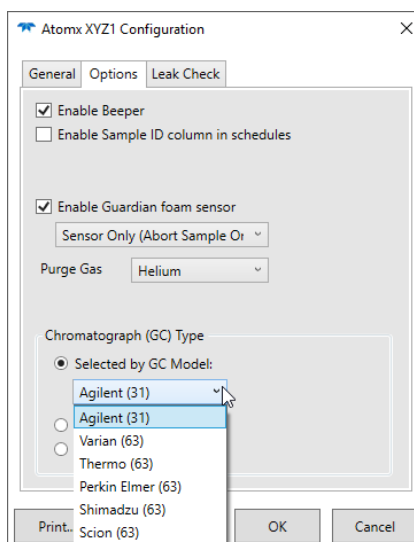

4. On the LEAK CHECK TAB:

- Customize LEAK CHECK PRESSURIZE TIME, LEAK CHECK FLOW pressure settings, and LEAK CHECK DELTA (amount of change in pressurization that indicates a leak).

Figure 2-28 Leak Check Tab

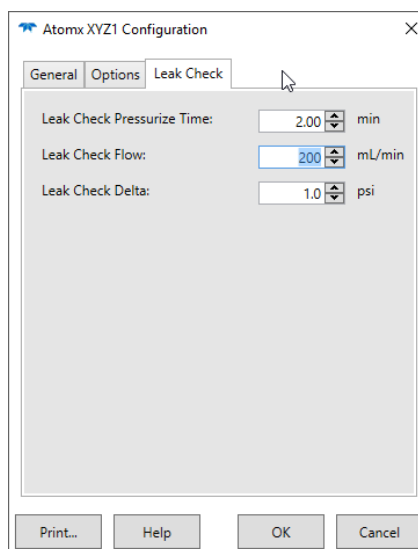

- Select the OK BUTTON to create the instrument profile. Atomx XYZ TekLink will automatically connect to the new profile and set it to default. The profile, and its properties can be viewed by selecting the TOOLS TOOLS>INSTRUMENT MANAGER.

Figure 2-29 Instrument Manager Showing Instrument Connected and Default Profile

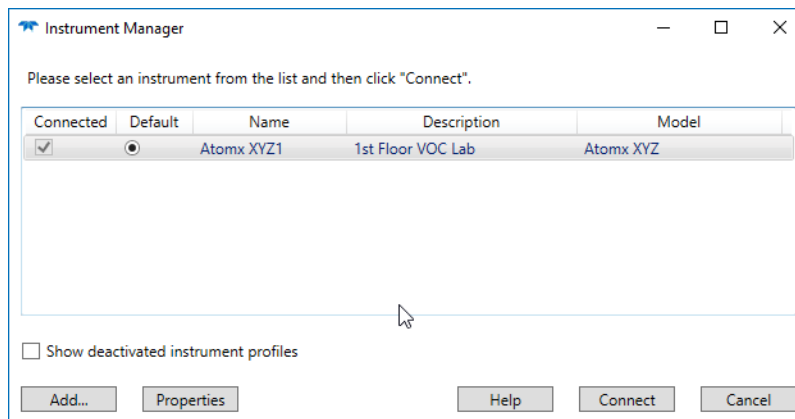

- The INSTRUMENT STATUS PANEL, METHODS SCREEN and SCHEDULES SCREEN will display the connected instrument profile name. Once created, methods, schedules, system properties, and preferences can be saved to that profile.



Once an instrument profile has been created it cannot be deleted. "Deactivating" an instrument profile removes the instrument profile from the list of active profiles in the Instrument Manager Dialog. For information on deactivating an instrument profile, refer to 3.7.2 "Deactivate an Instrument Profile".

## 2.11 Guardian Foam Sensor and Foam Eliminator (Optional)

The Guardian Foam Sensor and Foam Eliminator are designed to safeguard the Atomx XYZ from the adverse effects of liquid entering the gas pathway. The foam sensor uses a photo sensor mounted on the outside of the sparger to detect the presence of foam in the neck of the sparger. Upon detection, the foam sensor immediately stops the purge gas flow and contains the foaming sample in the sparger before it reaches the Atomx XYZ's gas pathway. When combined with the optional foam eliminator, a defoamer is added to the sample.

If ordered with the Atomx XYZ, the Guardian Foam Sensor and/or Foam Eliminator will be installed. To retrofit a Atomx XYZ with the Guardian Foam Sensor and/or Foam Eliminator refer to the installation instruction sheet included with the Guardian Foam Sensor and Foam Eliminator.

Guardian Foam Sensor and the Eliminator actions vary according to configuration (foam sensor with or without foam eliminator) and sensor/eliminator settings in TOOLS>CONFIGURATION>OPTIONS TAB.

### 2.11.1 Atomx XYZ with Guardian Foam Sensor

1. When foam is sensed, the Atomx XYZ shuts off the purge gas and aborts the sample.
2. If ABORT SAMPLE is selected in the TOOLS>CONFIGURATION>OPTIONS TAB:
  - The sample will be aborted. The Atomx XYZ will report that there was a foaming sample. Aborted will be displayed in the Status Column, and Yes will be displayed in the Foam Column beside the sample that foamed.
  - Once drained, the Atomx XYZ steps to the Desorb Preheat Mode to keep the GC sequence correct.
  - The next line of the sample schedule will be run.
3. If ABORT SCHEDULE is selected in TOOLS>CONFIGURATION>OPTIONS TAB:
  - The Atomx XYZ will go into Abort Mode and perform a system cleanup.
  - ABORTED will be displayed in the STATUS COLUMN of the foaming sample and all pending samples. YES will be displayed in the FOAM COLUMN beside the ONE sample that did foam.

### 2.11.2 Atomx XYZ with Guardian Foam Sensor and Foam Eliminator

1. When foam is sensed, the Atomx XYZ shuts off the purge gas. The purge clock is stopped and the Foam Transfer Valve is activated to add a defoaming agent.
2. The purge gas and purge clock are reactivated. If the sensor does not trip again, the Atomx XYZ will proceed with the sequence.
3. If the sensor is tripped a second time, the defoaming procedure is repeated.
4. If the sensor is tripped a third time, the system gives an error that is written to the SAMPLE HISTORY LOG (TOOLS>VIEW HISTORY LOG>SAMPLE HISTORY TAB).
5. If ABORT SAMPLE is selected in the TOOLS>CONFIGURATION>OPTIONS TAB:
  - The sample will be aborted. The Atomx XYZ will go to Desorb Preheat Mode to keep the GC schedule correct. ABORTED will be displayed in the STATUS COLUMN and YES in the sample's FOAM COLUMN.
  - The schedule will continue with the next sample.
6. If ABORT SCHEDULE is selected in TOOLS>CONFIGURATION>OPTIONS TAB:
  - The current sample and all remaining samples in the schedule will be aborted. The Atomx XYZ will report that there was a foaming sample. ABORTED will be displayed in the STATUS COLUMN of the foaming sample and all pending samples. YES will be displayed in the FOAM COLUMN beside the ONE sample that did foam.

### 2.11.3 Configuring the Guardian Foam Sensor & Eliminator

If not previously accomplished, activate and configure the Guardian Foam Sensor and Foam Eliminator:

1. Navigate to TOOLS>CONFIGURATION>OPTIONS TAB.
2. Select the check-box beside ENABLE GUARDIAN FOAM SENSOR.
3. Use the drop-down menu to configure the Guardian Foam Sensor and Eliminator actions.

Figure 2-30 Configuration Dialog- Guardian Foam Sensor

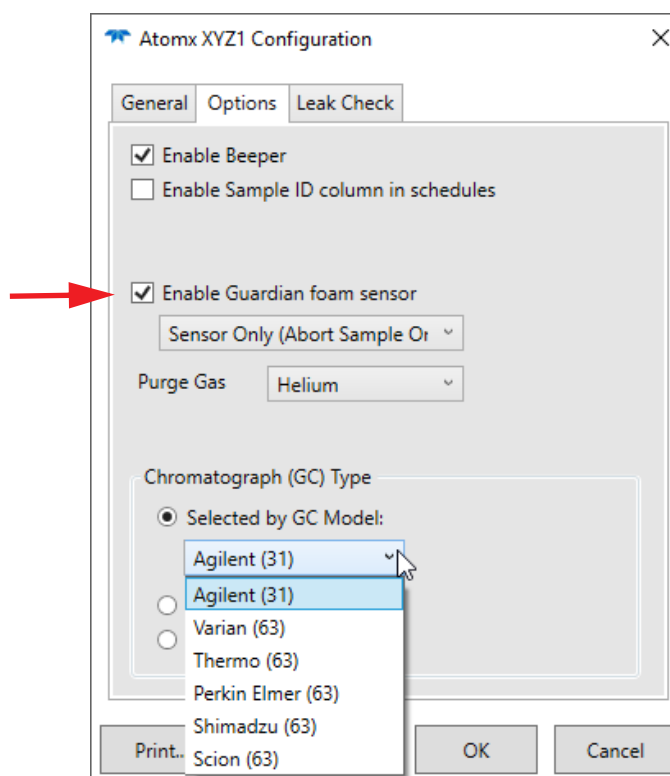

## 2.12 Preparing DI Water

The Atomx XYZ requires a source of DI water for system rinsing, auto-blanks, dilutions and high temperature system rinse. To avoid contamination problems, use blank (organic-free) water. Teledyne Tekmar recommends using deionized (DI) water. Several methods for preparing blank water are listed below:

- Pass distilled water through a column of activated carbon at least 12" (3.66 m) deep. Locate the supply vessel at a higher elevation than the collection vessel, with the supply line entering the column at the bottom.
- Boil water, then purge it at 80 ° - 90 °C with helium or nitrogen for at least one hour.
- Pass water through a freshly charged Millipore Super Q® water purifier.

## 2.13 Methanol Supply Grade

The system requires a supply of methanol if methanol extraction methods and the methanol bake rinse cleaning technique are to be used. Teledyne Tekmar recommends using a 4 L bottle of purge and trap grade methanol.

## 2.14 Preparing Working Standards

Commercially available standards, in various mixtures and concentrations, are available for volatile analysis. These standards should be kept at 0° C with a minimum of headspace. The longevity of the standard is generally defined by the manufacturer, or the specific analytical method.

In order to use the Internal Standard Vessels and the automatic spiking capability, a working solution must be created. This requires dilution of the stock standard and final concentration calculation. Refer to Section 2.14.1 "Working Standard Sample Calculation".

### 2.14.1 Working Standard Sample Calculation

#### General

- X = Stock standard injected into the volumetric flask (mL)
- A = Final concentration desired (ppb)
- B = Sample Volume (mL)
- C = Internal standard injection volume (µL)
- D = Volumetric flask volume (mL)
- E = Stock standard concentration (ppm)

#### Example

- A = 5 ppb
- B = 25 mL
- C = 2 µL
- D = 10 mL
- E = 2000 ppm

$$\left( \frac{5 \cdot 25 \cdot 25}{2 \cdot 2000} \right) = 0.3125 \text{ mL} = 31$$



# Atomx XYZ User Manual

## Chapter 3: Atomx XYZ TekLink Software Overview



### NOTE

For Atomx XYZ TekLink computer requirements refer to Section 2.1.6 "Minimum Computer Requirements". For information on installing Atomx XYZ TekLink refer to Section 2.9 "Install Atomx XYZ TekLink Software".

### 3.1 About Atomx XYZ TekLink Software

Atomx XYZ TekLink is a software user interface designed for the following functions:

- Define custom methods or operating sequences that meet analytical requirements by defining Standby, Purge, Desorb and Bake parameters.
- Create multi-line schedules.
- Load (Start), Hold and Abort a sample schedule.
- Troubleshoot and perform diagnostics on the system using advanced diagnostics.

### 3.2 The Atomx XYZ TekLink Software Environment

Atomx XYZ TekLink software is designed for convenient monitoring of the system while it is running. The sections below detail the primary user features of the software.

#### 3.2.1 Touchscreen Capability

Atomx XYZ TekLink software is designed to be used with touchscreen computers. All screens have active hot-spots, check-box selections or drop-down menus. An optional on-screen alpha-numeric keyboard can be enabled via TOOLS>SYSTEM PROPERTIES>MISC TAB.

Figure 3-1 On-Screen Keyboard



### 3.2.2 “Pinnable” Screens

All screens can be “pinned” so that they remain in view when the HOME SCREEN is reduced. Use the pin in the upper right-hand corner of the screen to “pin” and “unpin” each screen.

- When the pin is horizontal, the screen will be reduced from view when the HOME SCREEN is reduced.
- When the pin is vertical, the screen will remain visible when the HOME SCREEN is reduced. The screen can still be reduced using the MINIMIZE BUTTON.

Figure 3-2 Pin Function



### 3.2.3 Title Bar

The title bar of the METHODS and SCHEDULES SCREEN displays information on the active instrument profile, and the active schedule or method (according to screen).

Figure 3-3 Schedules Screen Title Bar

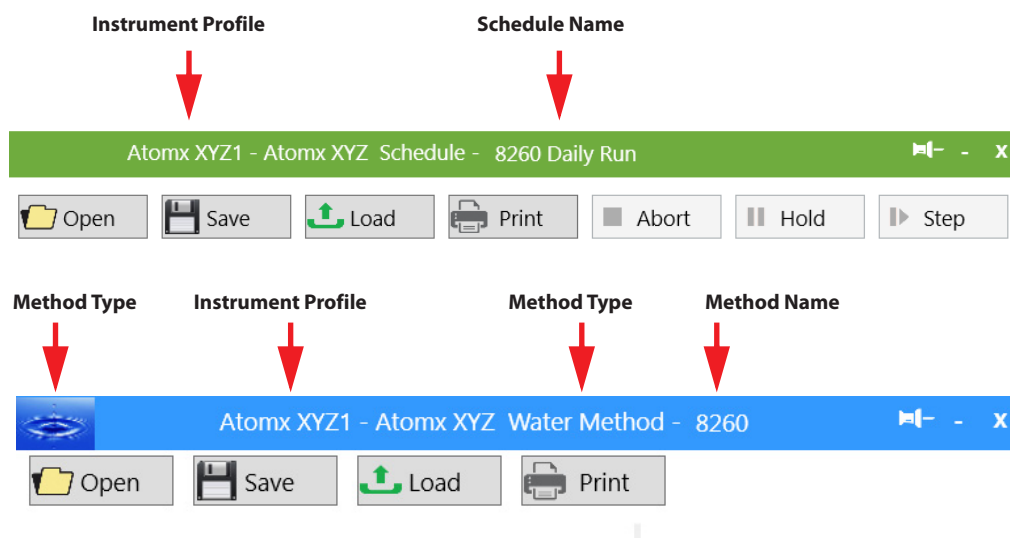

### 3.2.4 Open, Save, Load, and Print Buttons

Figure 3-4 Open, Save, Load, and Print Buttons



- **OPEN BUTTON** - Opens a default or previously saved method from the METHODS SCREEN or previously saved schedules from the Schedules Screen. The OPEN METHOD/SCHEDULE DIALOG shows saved methods and schedules by name and last modified date. To open a method or schedule that has been archived, select the appropriate ARCHIVE from the SOURCE DROP-DOWN in the OPEN METHOD/SCHEDULE DIALOG. Multiple methods may be opened for comparison.



#### NOTE

Methods and schedules are saved according to instrument profile and will not be available under a different instrument profile from which they were created/saved.

- **SAVE BUTTON** - Save the currently open method or schedule.



#### NOTE

Atomx XYZ TekLink includes default water, soil, and methanol extraction methods that cannot be over-written. To use a default method, open it from the Method Screen or select it from the Method Drop-down on the Schedules Screen. Refer to Section 3.8.3 "Open a Method" and Section 3.9 "Using the Schedule Screen".

- **LOAD BUTTON** - Load the currently open method or schedule.  
 When a method is loaded, the system will begin heating to temperature set-points as defined in the method. After temperature set-points are reached, the system will go into standby/purge ready. When a schedule is loaded (and temperature set-points in the method are met), the schedule will begin to run.
- **PRINT BUTTON** - Print the currently open method or schedule.

### 3.2.5 Instrument Control Buttons

The INSTRUMENT STATUS PANEL and the SCHEDULES SCREEN have control buttons that are used to ABORT or HOLD a schedule, or STEP through modes.

Figure 3-5 Control Buttons



### 3.2.6 Delete at Next Archive Check-Box

The DELETE AT NEXT ARCHIVE CHECK-BOX is available on both the METHODS and SCHEDULES SCREENS. When selected, the method or schedule will be deleted from the list of CURRENT methods or schedules in the OPEN METHOD/SCHEDULE DIALOGS and saved to the “archive” location.

Figure 3-6 Delete at Next Archive Check-Box - Schedule Screen

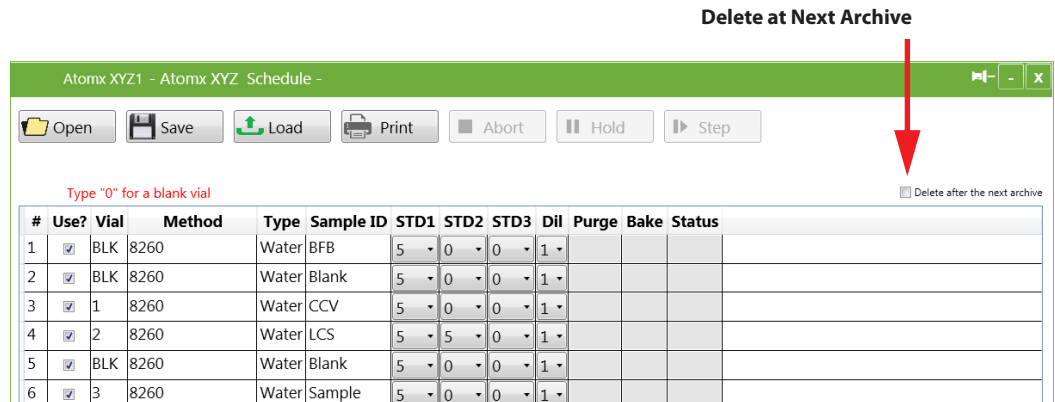

Once archived, the method or schedule can then be viewed by selecting the appropriate ARCHIVE in the OPEN SCHEDULE DIALOG’S SOURCE DROP-DOWN MENU (Figure 3-7).



Archive settings and the Archive Now command are located under Tools>System Properties>Data Tab.

Figure 3-7 Open Schedule Dialog Source Drop-down Menu

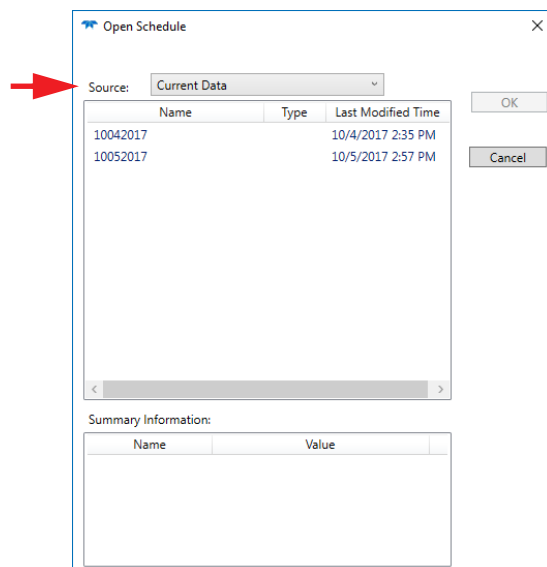

### 3.3 Primary Screens

#### 3.3.1 The Home Screen

The HOME SCREEN contains buttons to navigate to TekLink’s three primary screens and the Atomx XYZ TekLink Help:

- METHODS SCREEN - Specific to each type of analysis (Water, Soil, and Methanol Extraction). Used for defining Standby, Purge, Desorb and Bake method parameters as well as opening, saving, loading, and printing methods.
- SCHEDULES SCREEN- Used for creating and saving new sample schedules, opening previously created schedules, and printing an open schedule. When schedules are loaded from the SCHEDULES SCREEN the sample run begin.
- TOOLS SCREEN - Used for direct control of Atomx XYZ functions for troubleshooting and diagnostics. The TOOLS SCREEN also contains software configuration options and settings, and sample, instrument, and error logs.
- HELP - Atomx XYZ TekLink Help is context sensitive and provides information on the software and instrument functionality.

Figure 3-8 Home Screen

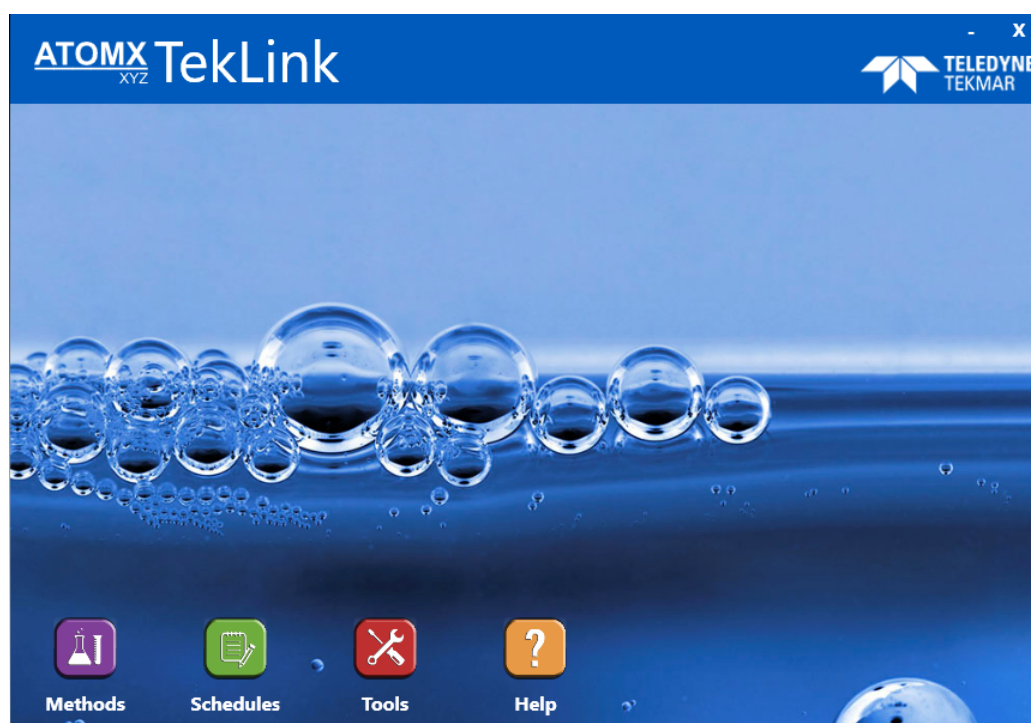

### 3.3.2 Instrument Status Panel

The INSTRUMENT STATUS PANEL contains information related to system operation including the schedule that is running, the current method, the current position in the schedule being run, as well as the mode and time remaining. Similar to the SCHEDULES SCREEN, control buttons can be used to ABORT or HOLD a schedule or STEP through modes.

Figure 3-9 Instrument Status Panel

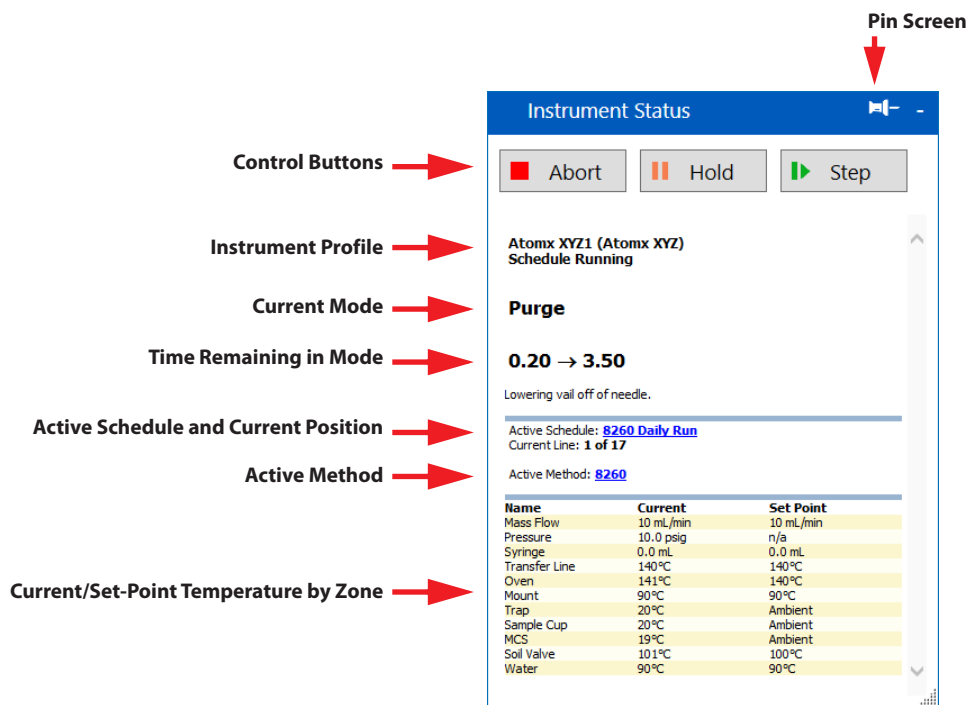

**NOTE**

Right-clicking on the Zones Panel of the Instrument Status Screen will show additional display options.

Figure 3-10 Instrument Status Zone Display Options

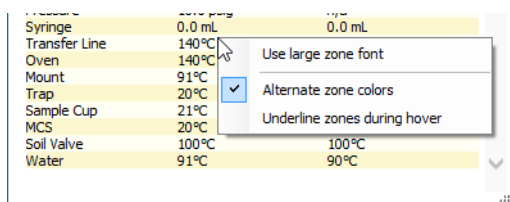



### 3.4 Methods Screen

The METHODS SCREEN contains STANDBY, PURGE, DESORB and BAKE TABS for defining method parameters. Because method parameters vary according to the type of analysis conducted on the Atomx XYZ, the user is first prompted to select a method type (WATER, SOIL, METHANOL).

Figure 3-11 Choose Method Type Dialog

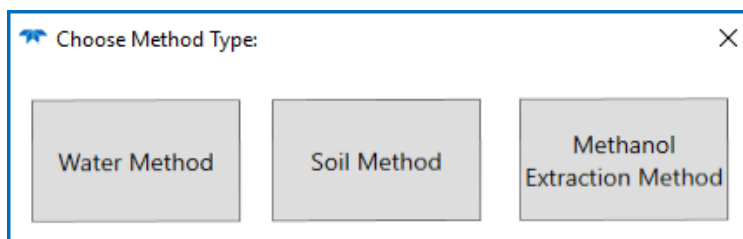

Once the method type is selected, the header of the screen and the parameters contained on each of the screen's tabs will correspond to that type of analysis.

Figure 3-12 Methods Screen Water, Soil, and Methanol Extraction Headers

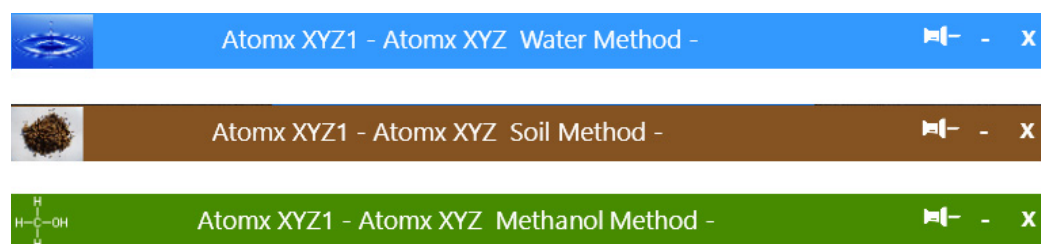

Multiple Methods Screens can be opened for comparison of one method to another.

#### 3.4.1 Standby Tab



The parameters on the Standby Tab are the same for Water, Soil and Methanol methods.

The STANDBY TAB is used to set standby temperatures and flows. Of particular note are the following parameters:

- STANDBY FLOW

The amount of purge gas flow sweeping the sample pathway while the system is idle.

- **MOISTURE CONTROL SYSTEM (MCS) READY TEMP**  
The temperature set-point for the MCS that must be reached before stepping to Purge Mode. Set approximately 10-20 degrees higher than ambient air temperature to decrease cycle time.
- **PURGE READY TEMP**  
The temperature set-point for the analytical trap that must be reached before stepping to Purge Mode. Set approximately 10-20 degrees higher than ambient air temperature to decrease cycle time.

Figure 3-13 Water Methods Screen - Standby Tab

Name	Value	Unit
Valve Oven Temp	140	°C
Transfer Line Temp	140	°C
Sample Mount Temp	90	°C
Water Heater Temp	90	°C
Sample Cup Temp	20	°C
Soil Valve Temp	100	°C
Standby Flow	10	mL/min
MCS Ready Temp	45	°C
Purge Ready Temp	40	°C

Delete after the next archive

**Valve Oven Temp**  
Set the 6-port valve oven at a temperature high enough to prevent cross contamination, but not too high so as to decompose analytes.

Maximum 250°C  
Default 140°C  
Minimum 20°C

### 3.4.2 Purge Tab

The PURGE TAB is used to define the times, flows and temperatures of the Purge Mode. Parameters vary according to the method type chosen.

#### Water Method Purge Tab Options

☑
NOTE

Teledyne Tekmar recommends a sample gas flow of 40 mL/min ±5 mL for 11 minutes to achieve a 440 mL purge volume.

Of particular note are the following parameters:

- SPARGE VESSEL HEATER

If a sample heater is installed on the sparger, select the check-box next to the SPARGE VESSEL HEATER parameter to add the following parameters to the PURGE TAB:

- SPARGE VESSEL TEMP (Sparge Vessel Heater Enabled)

The sample temperature range is 20-90 °C. For environmental samples, the typical range is 40-60 °C. Flavor and fragrance analysis may have much higher temperatures.

- PRE-PURGE FLOW (Sparge Vessel Heater Enabled)

The amount of purge gas flow sweeping the sparger to remove oxygen in the headspace, prior to heating the sample. Usually pre-purge flow combined with pre-purge time allows the volume of the glassware to be swept three times.

- PRE-PURGE TIME (Sparge Vessel Heater Enabled)

The amount of time the sparger is swept with purge gas to remove oxygen in the headspace, prior to heating the sample. Usually pre-purge time combined with pre-purge flow allows the volume of the glassware to be swept three times.

- PREHEAT TIME (Sparge Vessel Heater Enabled)

Pre-heat time is used to allow the heaters to reach their temperature set-points before Purge to ensure that all samples are purged under the desired conditions.

Figure 3-14 Waters Methods Screen - Purge Tab - Sparge Vessel Heater Enabled

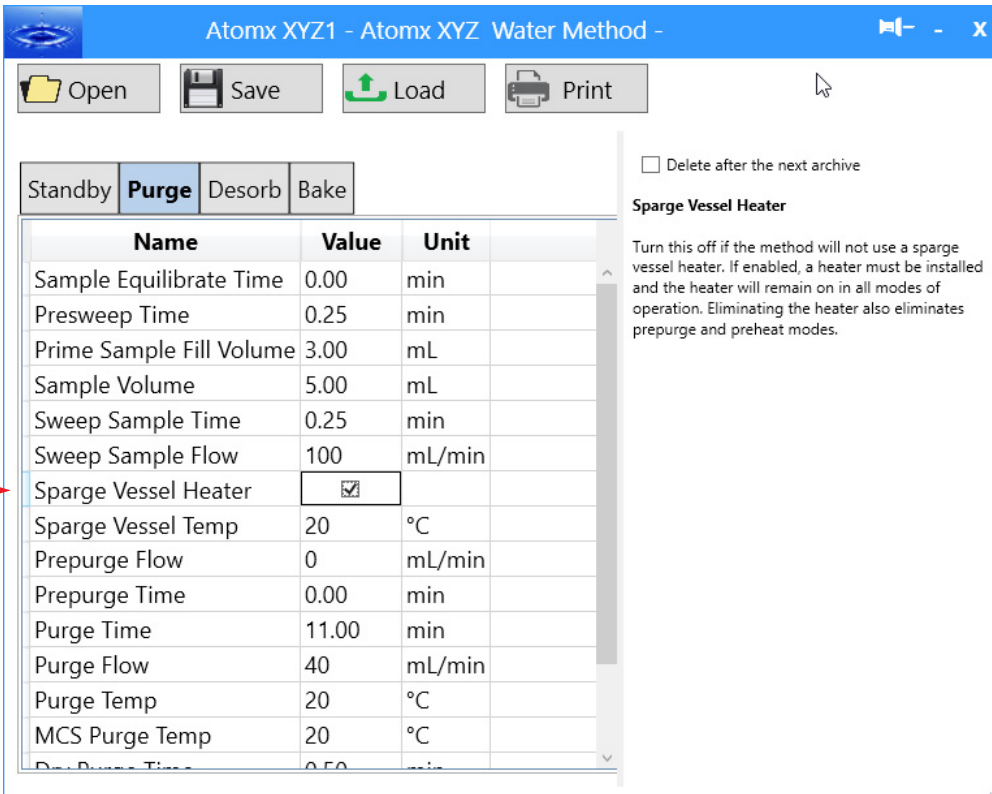

The screenshot shows the 'Purge' tab in the Waters Methods screen. A table lists various parameters with their values and units. The 'Sparge Vessel Heater' parameter is checked, and a red arrow points to it with the text 'Sparge Vessel Heater Enabled'. To the right, a section titled 'Sparge Vessel Heater' contains a checkbox and explanatory text.

Name	Value	Unit
Sample Equilibrate Time	0.00	min
Presweep Time	0.25	min
Prime Sample Fill Volume	3.00	mL
Sample Volume	5.00	mL
Sweep Sample Time	0.25	min
Sweep Sample Flow	100	mL/min
Sparge Vessel Heater	<input checked="" type="checkbox"/>	
Sparge Vessel Temp	20	°C
Prepurge Flow	0	mL/min
Prepurge Time	0.00	min
Purge Time	11.00	min
Purge Flow	40	mL/min
Purge Temp	20	°C
MCS Purge Temp	20	°C
Desorb Time	0.50	min

Delete after the next archive

**Sparge Vessel Heater**

Turn this off if the method will not use a sparge vessel heater. If enabled, a heater must be installed and the heater will remain on in all modes of operation. Eliminating the heater also eliminates prepurge and preheat modes.

## Soil Method Purge Tab Options

Of particular note are the following parameters:

- PREHEAT MIX SPEED

This parameter allows for soils to be mixed during the Preheat Mode. By separating this parameter, the user can select a speed that is different from that of the Purge Mode.

- PURGE MIX SPEED

This parameter allows for the mixing of soil samples during Purge Mode to improve purge efficiency.

- WATER VOLUME

This parameter allows for the addition of water to soil samples. It will be necessary to add water if the user wishes to add internal standards to the sample via the automated standard addition feature of the Atomx XYZ.

Figure 3-15 Soil Methods Screen - Purge Tab

Atomx XYZ1 - Atomx XYZ Soil Method -

Open Save Load Print

Standby **Purge** Desorb Bake

Name	Value	Unit
Prepurge Time	0.00	min
Prepurge Flow	0	mL/min
Preheat Mix Speed	Slow	
Sample Preheat Time	0.00	min
Presweep Time	0.25	min
Water Volume	10.00	mL
Sweep Water Time	0.25	min
Sweep Water Flow	100	mL/min
Sparge Vessel Heater	<input type="checkbox"/>	
Purge Mix Speed	Medium	
Purge Time	11.00	min
Purge Flow	40	mL/min
Purge Temp	20	°C
MCS Purge Temp	20	°C

Delete after the next archive

**Prepurge Time**  
Use this time to sweep oxygen and CO2 from the sample matrix after being exposed to atmosphere. Generally used in specialized applications only.

Maximum 299.99 min  
Default 0.00 min  
minimum 0.00 min

## Methanol Extraction Method Purge Tab Options

Of particular note are the following parameters:

- METHANOL VOLUME

This parameter allows for the addition of methanol to methanol extraction samples. It will be necessary to add methanol if the user wishes to add internal standards to the sample via the automated standard addition feature of the Atomx XYZ.

- SAMPLE MIX SPEED

This parameter sets the speed at which the methanol extraction sample is mixed during the extraction step.

- SAMPLE MIX TIME

This parameter sets the amount of time that the methanol extraction sample is mixed.

- SAMPLE MIX SETTLE TIME

This parameter sets the amount of time the sample is allowed to settle before the methanol extract is withdrawn from the vial. Ensure that adequate settling time is allowed to prevent particulate matter from being drawn into the needle and syringe.

Figure 3-16 Methanol Extraction Methods Screen - Purge Tab

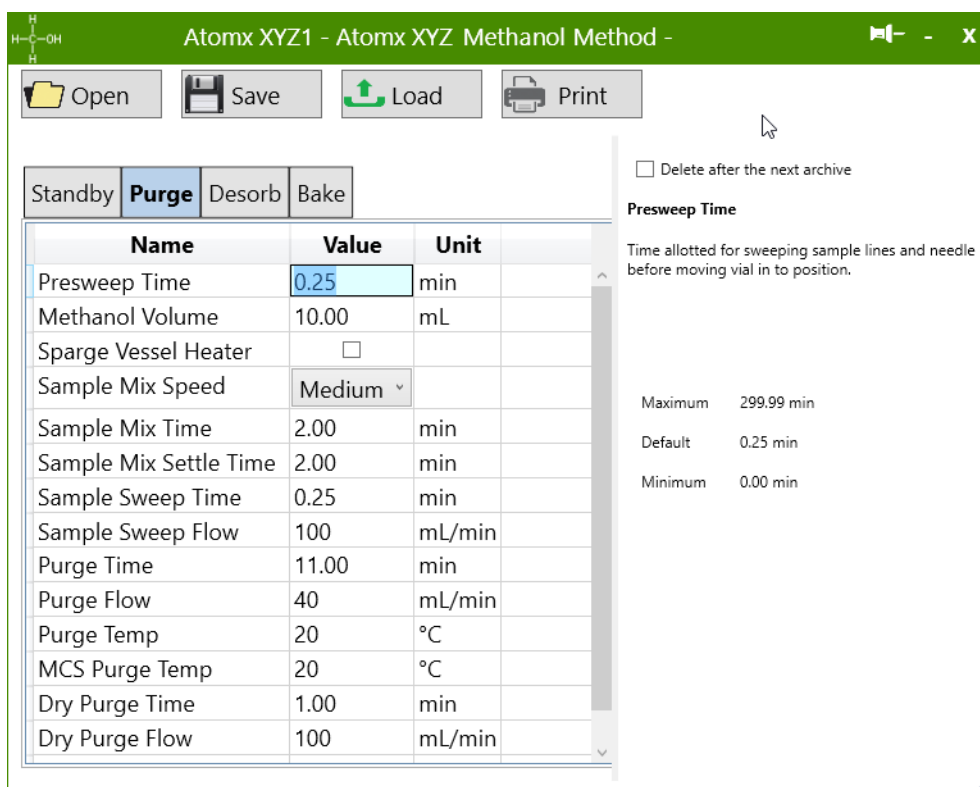

Atomx XYZ1 - Atomx XYZ Methanol Method -

Open Save Load Print

Standby **Purge** Desorb Bake

Name	Value	Unit
Presweep Time	0.25	min
Methanol Volume	10.00	mL
Sparge Vessel Heater	<input type="checkbox"/>	
Sample Mix Speed	Medium	
Sample Mix Time	2.00	min
Sample Mix Settle Time	2.00	min
Sample Sweep Time	0.25	min
Sample Sweep Flow	100	mL/min
Purge Time	11.00	min
Purge Flow	40	mL/min
Purge Temp	20	°C
MCS Purge Temp	20	°C
Dry Purge Time	1.00	min
Dry Purge Flow	100	mL/min

Delete after the next archive

**Presweep Time**  
Time allotted for sweeping sample lines and needle before moving vial in to position.

Maximum 299.99 min  
Default 0.25 min  
Minimum 0.00 min

### 3.4.3 Desorb Tab

**NOTE**

The parameters on the Desorb Tab are the same for Water, Soil and Methanol Extraction methods.

**NOTE**

Also refer to 4.5 "Analytical Trap Recommended Operating Conditions".

The DESORB TAB is used to define the times, flows and temperatures of the Desorb Mode. Of particular note are the following parameters:

- METHANOL NEEDLE RINSE ENABLE**

This parameter enables the system to rinse the needle and associated plumbing (including syringe) with methanol to reduce the amount of carryover seen after high concentration and/or samples with difficult matrices. Methanol rinses should always be followed with hot water rinses to ensure adequate removal of methanol from the system.
- METHANOL NEEDLE RINSE VOLUME**

Volume of methanol used to rinse the needle and associated sample lines.
- GC START SIGNAL**

Determines when the start signal is sent to the GC. Options include: BEGINNING of DESORB, END of DESORB and BOTH beginning and end (the latter two are typically used in conjunction with a cryofocusing inlet).

Figure 3-17 Waters Methods Screen - Desorb Tab

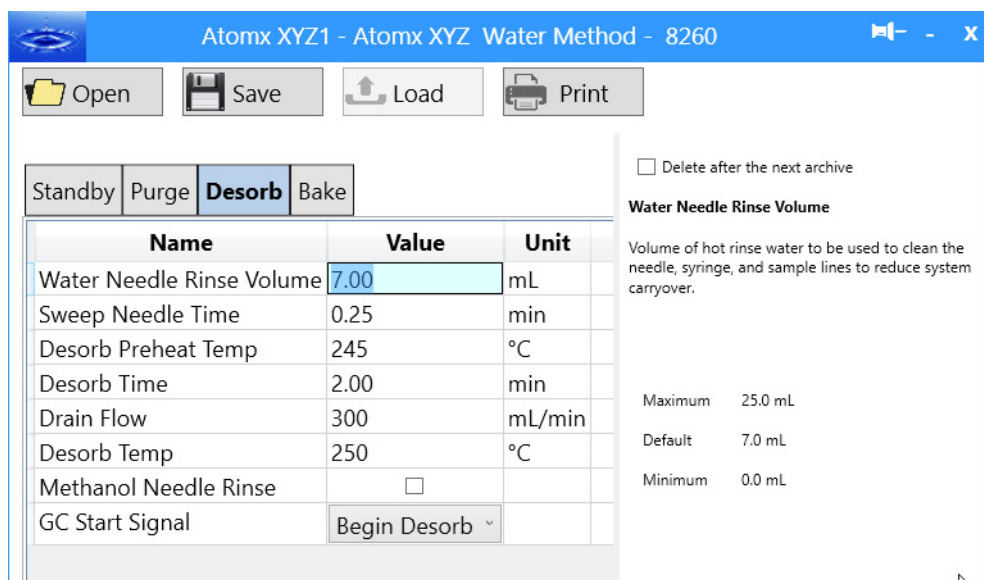

### 3.4.4 Bake Tab

The BAKE TAB is used to define the time, flow and temperature of the Bake Mode. Parameters vary according to the method type chosen.

#### Water and Methanol Extraction Method Bake Options

Of particular note are the following parameters:

- METHANOL GLASS RINSE ENABLE

This parameter enables the system to rinse the glassware and associated plumbing (including syringe) with methanol to reduce the amount of carryover seen after high concentration and/or samples with difficult matrices. Methanol rinses should always be followed with hot water rinses to ensure adequate removal of methanol from the system.

- NUMBER OF METHANOL RINSES

In many cases, one or two rinses, followed by a hot water rinse are sufficient for carryover reduction. The benefit of additional rinses should be weighed against the cost of methanol consumed, as well as the increase to total cycle time.

- METHANOL GLASS RINSE VOLUME (METHANOL EXTRACTIONS ONLY)

Volume of methanol to be used to rinse the sparger. A volume of one or two milliliters larger than the sample volume should be employed to ensure adequate rinsing of the glassware.

Figure 3-18 Water Methods Screen - Bake Tab

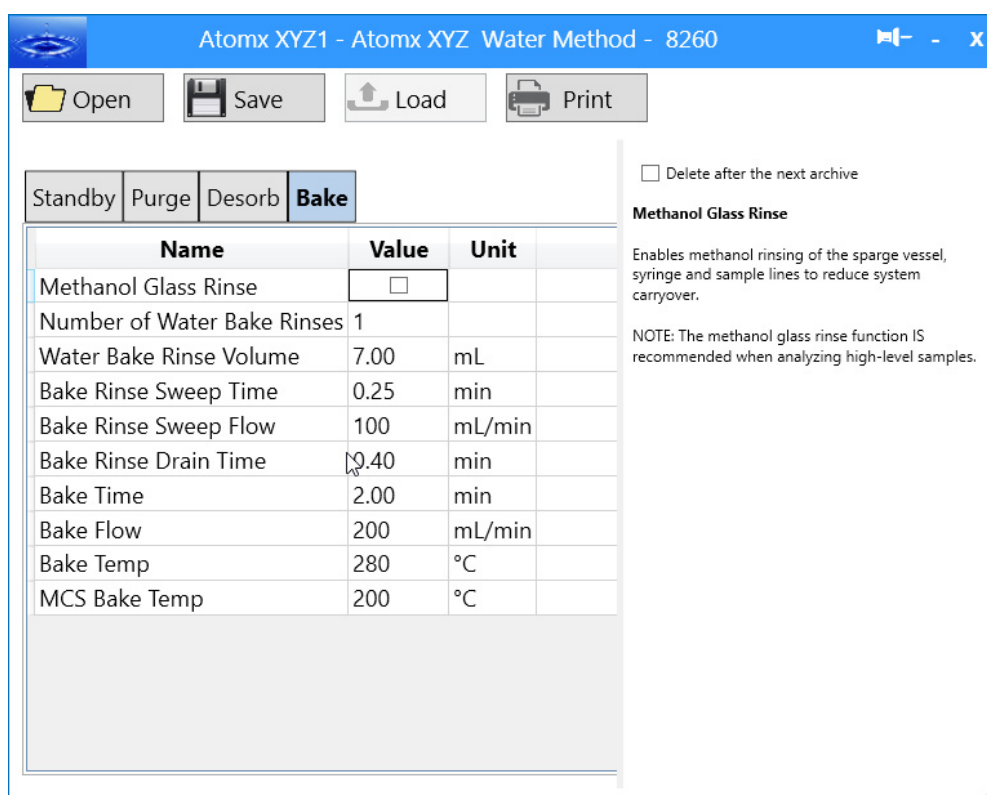

Atomx XYZ1 - Atomx XYZ Water Method - 8260

Open Save Load Print

Standby Purge Desorb **Bake**

Name	Value	Unit
Methanol Glass Rinse	<input type="checkbox"/>	
Number of Water Bake Rinses	1	
Water Bake Rinse Volume	7.00	mL
Bake Rinse Sweep Time	0.25	min
Bake Rinse Sweep Flow	100	mL/min
Bake Rinse Drain Time	0.40	min
Bake Time	2.00	min
Bake Flow	200	mL/min
Bake Temp	280	°C
MCS Bake Temp	200	°C

Delete after the next archive

**Methanol Glass Rinse**

Enables methanol rinsing of the sparge vessel, syringe and sample lines to reduce system carryover.

NOTE: The methanol glass rinse function IS recommended when analyzing high-level samples.



Figure 3-19 Methanol Methods Screen - Bake Tab

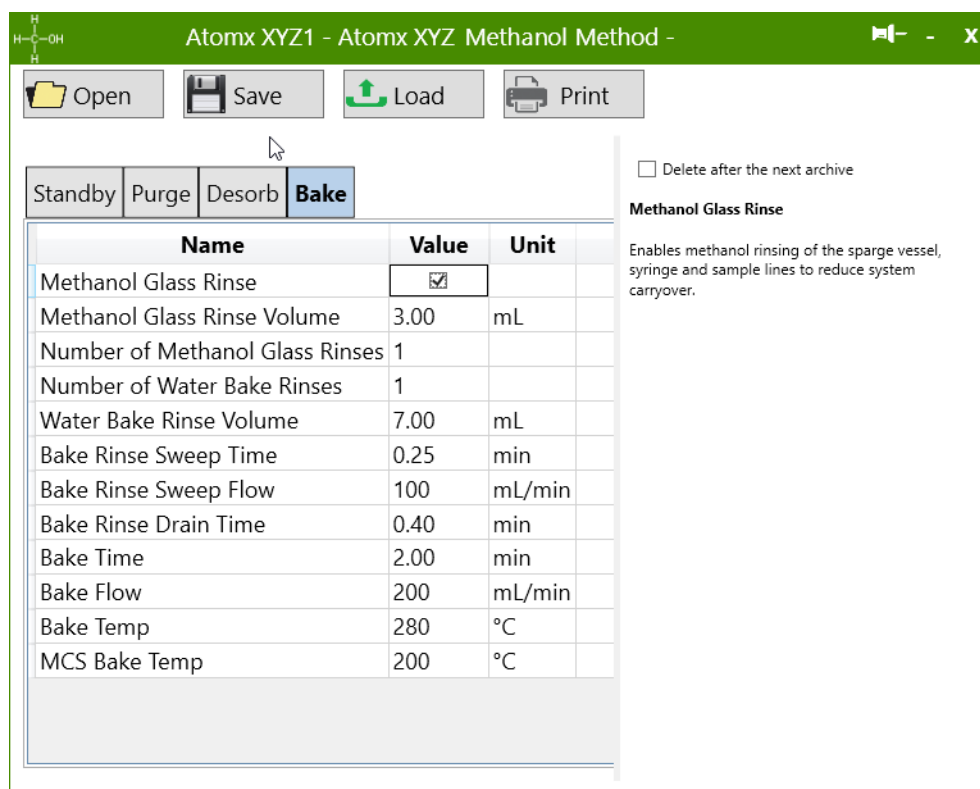

### 3.5 Schedules Screen

The SCHEDULES SCREEN is used for creating and saving new sample schedules, opening previously created schedules, and printing an open schedule. Schedules are “loaded” using the LOAD BUTTON on the SCHEDULES SCREEN. Once a schedule is loaded, the system will begin heating to temperature set-points as defined in the method (if the method was not previously loaded from the METHOD SCREEN). Once set-points are achieved, the sample schedule will begin to run.

Control buttons at the top right are used to ABORT or HOLD a schedule once it has been loaded, or to STEP through modes.

The columns of the SCHEDULE TABLE are used for the following:

- # - The line number of the sample/blank.
- USE - Selecting/deselecting the USE check-box includes/excludes that line from the schedule. The USE check-box allows the convenient revision of a previously saved schedule.
- VIAL - The autosampler vial position that corresponds to that line of the schedule. Blanks can be added to the schedule by entering “0” in the vial position and hitting <Enter>.
- METHOD - A drop-down menu that allows the selection of default water, soil and methanol methods, as well as any custom methods saved in the CURRENT or ARCHIVED DATA folders.

- **TYPE** - The sample type is automatically input and corresponds to the type of method selected.
- **SAMPLE ID** - Allows the entry of the Sample ID in the schedule (and report). This column is only shown when **ENABLE SAMPLE ID COLUMN IN SCHEDULES** is selected on the **OPTIONS TAB** of the **INSTRUMENT CONFIGURATION DIALOG**. Select **TOOLS SCREEN>CONFIGURATION>OPTIONS TAB**.
- **STD1, STD2 and STD3** - These columns permit the addition of check and/or internal standards to the sample when running water and soil methods. When the Atomx XYZ is running a methanol extraction sample, **STD3** is reserved for a matrix spike to be added to the vial prior to extraction.



## NOTE

When adding automatic standard additions to soil and methanol extraction samples, ensure that a corresponding water or methanol volume is also configured via **Methods Screen>Purge Tab**. Refer to Section 3.4.2 "Purge Tab".

- **PURGE** - Records the amount of back-flow pressure through the analytical trap, during Purge Mode. This value can be used as a diagnostic and troubleshooting tool.
- **BAKE** - Records the amount of back-flow pressure through the analytical trap during Bake Mode. This value can be used as a diagnostic and troubleshooting tool.
- **FOAM** - Only shown if the Guardian Foam Sensor or Guardian Foam Sensor and Eliminator has been enabled in **TOOLS>CONFIGURATION>OPTIONS TAB**. For information on what the column displays according to configuration and settings, refer to Section 2.11 "Guardian Foam Sensor and Foam Eliminator (Optional)".
- **STATUS** - The status of the sample being run. Status will indicate **PENDING, COMPLETED, ABORTED, and HOLD**.

Figure 3-20 Schedules Screen - Foam Column Not Enabled

#	Use?	Vial	Method	Type	Sample ID	STD1	STD2	STD3	Dil	Purge	Bake	Status
1	<input checked="" type="checkbox"/>	BLK	8260	Water	BFB	5	0	0	1			
2	<input checked="" type="checkbox"/>	BLK	8260	Water	Blank	5	0	0	1			
3	<input checked="" type="checkbox"/>	1	8260	Water	CCV	5	0	0	1			
4	<input checked="" type="checkbox"/>	2	8260	Water	LCS	5	5	0	1			
5	<input checked="" type="checkbox"/>	BLK	8260	Water	Blank	5	0	0	1			
6	<input checked="" type="checkbox"/>	3	8260	Water	Sample	5	0	0	1			
7	<input checked="" type="checkbox"/>	4	8260	Water	Sample	5	0	0	1			
8	<input checked="" type="checkbox"/>	5	8260	Water	Sample	5	0	0	1			
9	<input checked="" type="checkbox"/>	6	8260	Water	Sample	5	0	0	1			
10	<input checked="" type="checkbox"/>	7	8260	Water	Sample	5	0	0	1			
11	<input checked="" type="checkbox"/>	8	8260	Water	Sample	5	0	0	1			
12	<input checked="" type="checkbox"/>	9	8260	Water	Sample	5	0	0	1			
13	<input checked="" type="checkbox"/>	10	8260	Water	Sample	5	0	0	1			
14	<input checked="" type="checkbox"/>	11	8260	Water	Sample	5	0	0	1			
15	<input checked="" type="checkbox"/>	12	8260	Water	Sample	5	0	0	1			
16	<input checked="" type="checkbox"/>	13	8260	Water	Spike1	5	0	5	1			
17	<input checked="" type="checkbox"/>	14	8260	Water	Spike2	5	0	5	1			

### 3.6 Tools Screen

The TOOLS SCREEN is used for direct control of system functions for troubleshooting and diagnostics. It also contains software preferences and configuration options and settings as well as sample, instrument, and error logs.

Figure 3-21 Tools Screen

### 3.6.1 Prime Menu

The PRIME MENU contains controls for priming the Atomx XYZ standards, DI water, and methanol supply tubing.



#### NOTE

Priming removes air from the tubing lines and should be performed whenever the standard addition vials, DI water supply or methanol supply have been disconnected.

- STANDARD 1 BUTTON  
Prime Standard 1 vessel tubing.
- STANDARD 2 BUTTON  
Prime Standard 2 vessel tubing.
- STANDARD 3 BUTTON  
Prime Standard 3 vessel tubing.
- ALL STANDARDS BUTTON  
Primes Standards 1, 2 and 3 vessels tubing.
- WATER BUTTON  
Prime the DI water supply tubing.
- METHANOL BUTTON  
Prime the methanol supply tubing.

### 3.6.2 Commands Menu

#### Leak Check

- Activates the Atomx XYZ leak check function. The system performs a leak check by closing specific valves and shutting down the Mass Flow Controller (MFC) to isolate the pressurized system. Once isolated, the Atomx XYZ will take pressure readings to identify any pressure loss that would indicate a leak.



#### NOTE

Leak check settings (Check Pressurize Time, Flow and Delta) are defined on the Tools>Configuration>Leak Check Tab.

Figure 3-22 Instrument Status Showing Leak Check Mode

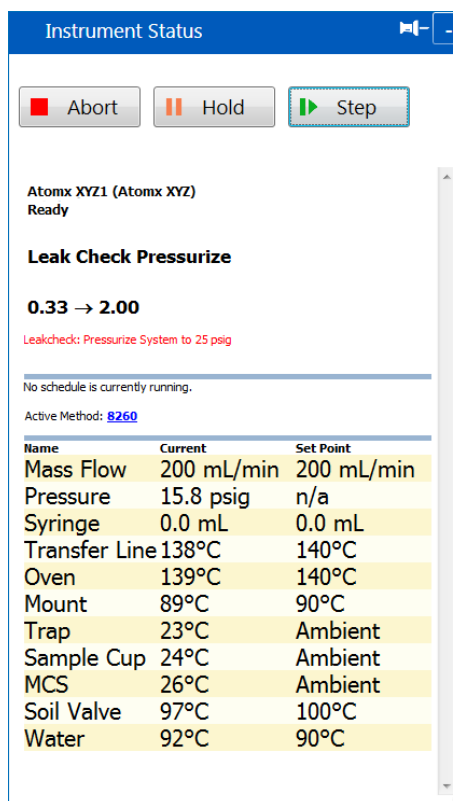

### Go to Bake

The Go to BAKE BUTTON will display the BAKE DIALOG. The BAKE DIALOG permits the manual configuration of Bake Mode settings and automatically steps the system to Bake Mode. The dialog also contains selection boxes for high-temperature DI water bake rinse or methanol rinse in which the liquid sample path is cleaned to reduce carryover between samples.



Manually activated bake settings are typically used to condition a new analytical trap. Refer to Section 5.14 "Analytical Trap Conditioning" and recommended trap conditioning settings from the trap manufacturer.

The dialog permits the manual override/configuration of the following:

- Bake Time
- Trap Bake Temperature
- Moisture Control System Bake Temperature
- Bake Flow
- DI Water and Methanol Bake Rinse

The dialog contains selection boxes for the following sample pathway rinses to reduce carryover:

- PERFORM METHANOL RINSE(S) - Set the number of methanol rinse cycles (up to 3) and methanol rinse volume (1-25 mL).
- PERFORM DI WATER RINSE(S) - Set the number of bake rinse cycles (up to 3) and bake rinse volume (1-25 mL).

Figure 3-23 Bake Dialog

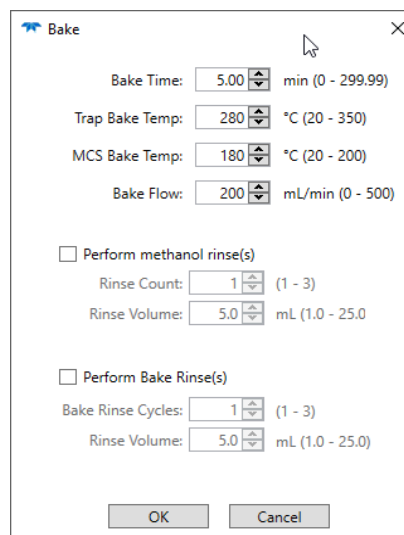

### Go to Desorb

The Go to DESORB BUTTON manually steps the system to Desorb Mode. The system will use the desorb settings as configured in the currently active method.

### Internal Standard Pressure Check

Select the CHECK STANDARD PRESSURE BUTTON to display internal standard vessel pressure readings in the INSTRUMENT STATUS PANEL.



Refer to Section 5.10 "Verifying/Setting Internal Standard Vessel Pressure".

### Change Syringe Wizard

Select the CHANGE SYRINGE WIZARD BUTTON to display the INITIALIZE/CHANGE SYRINGE WIZARD. Follow the wizard's prompts through the syringe change procedure. Once the syringe has been replaced, the wizard will then initialize the syringe.

### Align Autosampler

Select the ALIGN AUTOSAMPLER BUTTON to display the AUTOSAMPLER ALIGNMENT WIZARD. The wizard is used to align the X, Y, and Z axis of the autosampler arms through a sequence of steps. Refer to the Section 5.16 "XYZ Autosampler Alignment".

### 3.6.3 System Menu

#### Configuration - General Tab

The GENERAL TAB displays information related to the current instrument profile and connection.



#### NOTE

The Instrument Manager is used to create new instrument profiles once the initial profile has been created after software installation. For information on creating, connecting to and deactivating instrument profiles refer to Section 3.7 "Add, Connect and Deactivate an Instrument Profile".

- NAME - Name of the active or selected instrument.
- DESCRIPTION - A user-defined, brief set of text identifying the instrument.
- CONNECTION - Defaults to USB
- DEACTIVATE THIS INSTRUMENT PROFILE CHECK-BOX - disables the instrument profile.



#### NOTE

When an instrument profile has been "deactivated" it will not show in the selection of instrument profiles available via Tools>Instrument Manager unless the "Show deactivated instrument profiles" Check-Box is selected in that dialog.

Figure 3-24 Tools - Configuration - General Tab

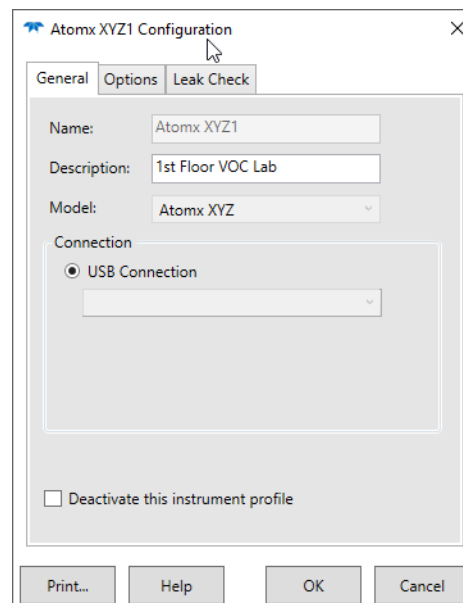



### Configuration - Options Tab

- ENABLE BEEPER - Enables/disables the system beeper for instrument errors.
- ENABLE GUARDIAN FOAM SENSOR - Enables/disables Guardian Foam Sensor functionality as well as defining the sensor and eliminator actions. Use the drop-down menu to choose from the following actions:
  - Sensor Only (Abort Sample Only)
  - Sensor Only (Abort Schedule)
  - Eliminator (Abort Sample Only)
  - Eliminator (Abort Schedule)

When selected, an additional FOAM COLUMN will be added to the Sample Schedule. For information on what the column displays according to configuration and settings, refer to Section 2.11 "Guardian Foam Sensor and Foam Eliminator (Optional)".

- PURGE GAS - Specifies the type of purge gas. Choose between ultra-high purity helium or nitrogen. The default gas is helium.



If this configuration is made incorrectly, the gas flow from the Mass Flow Controller (MFC) will not be accurate.

- GAS CHROMATOGRAPH TYPE - Use the SELECT BY GC MODEL DROP-DOWN MENU to select the GC. If the model is not found from the drop-down list, refer to the GC manufacturer's instructions and use the STANDARD TYPE:63 or USER TYPE:31 RADIO BUTTONS.

Figure 3-25 Tools - Configuration - Options Tab

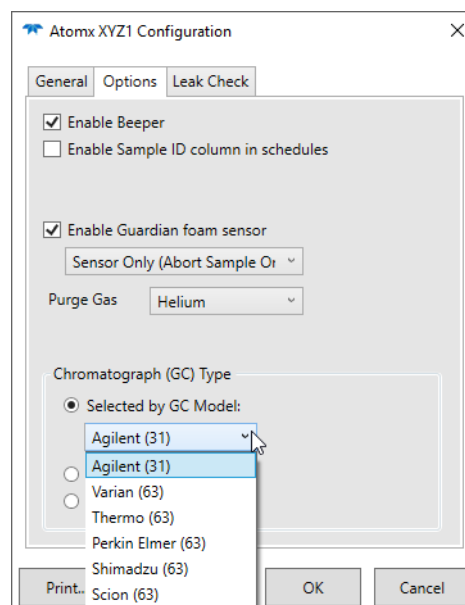

## Configuration - Leak Check Tab

LEAK CHECK TAB options include:

- LEAK CHECK PRESSURIZE TIME - The amount of time allowed for the system to become fully pressurized. The default pressurize time of 2 minutes will be sufficient for a majority of instrument configurations. Once the automated Leak Check has fully pressurized the system, it will step to the next test regardless of whether the pressurize time has been met or not.
- LEAK CHECK FLOW - The flow rate for the pressurization of the system during leak check.
- LEAK CHECK DELTA - The allowable difference in pressure readings that indicates a leak.

Figure 3-26 Tools - Configuration - Leak Check Tab

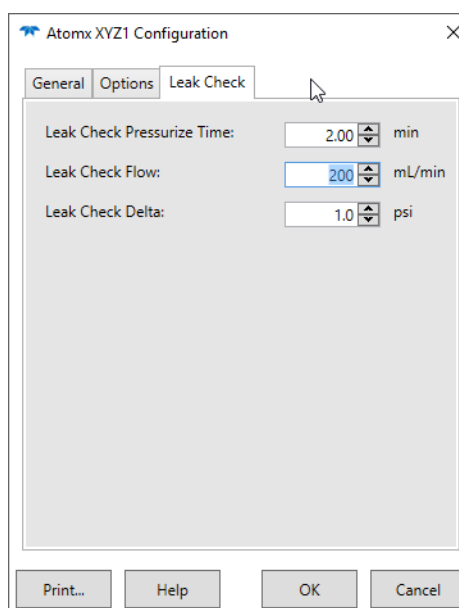

### NOTE

For the Leak Check procedure refer to Section 5.8 "System Leak Check".

## Instrument Manager

The INSTRUMENT MANAGER DIALOG is used to create, connect and view the properties of instrument profiles.

Figure 3-27 Tools - Instrument Manager

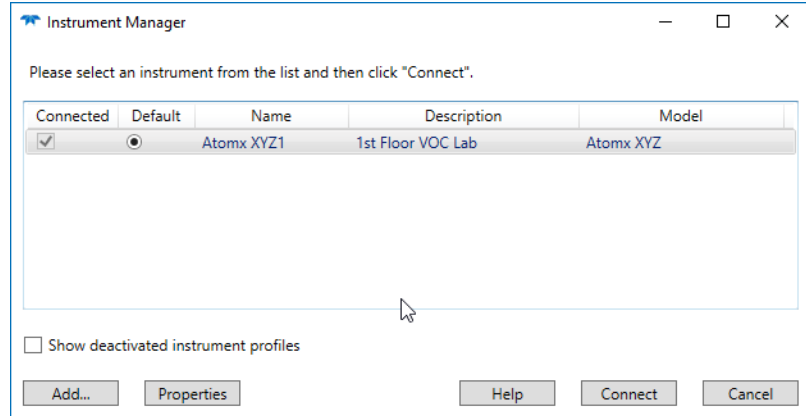

## System Properties

The SYSTEM PROPERTIES DIALOG contains archive settings for method, schedule, configuration and histories (sample, instrument, and error). The MISC TAB contains a selection box to display an on-screen keyboard.

Figure 3-28 System Properties Dialog

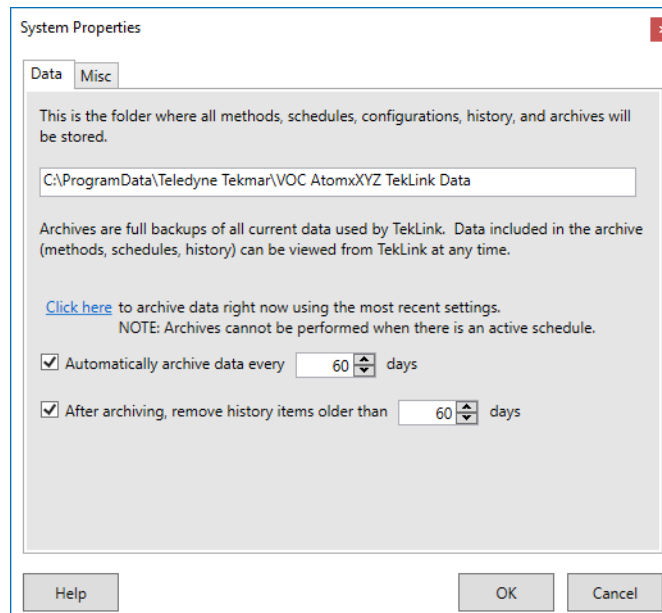

- DATA TAB - The DATA TAB displays the default location where Atomx XYZ TekLink stores methods, schedules, configurations, instrument history, and archived data.



The data storage location is not editable.

Archive data immediately by selecting “[CLICK HERE TO ARCHIVE DATA RIGHT NOW USING THE MOST RECENT SETTINGS](#)” or schedule regular intervals for archiving information.



Data cannot be archived when a schedule is running.

Archives are full backups of all current data used by Atomx XYZ TekLink. If the DELETE AFTER THE NEXT ARCHIVE CHECK BOX is selected on the METHOD or SCHEDULE SCREENS the method or schedule will be deleted at the archive event. Archived Schedules and Methods can be viewed at any time by using the OPEN BUTTON on the respective screen and selecting the SOURCE DROP-DOWN MENU to the appropriate ARCHIVE. SAMPLE, INSTRUMENT and ERROR HISTORY can be viewed by changing the FILTER settings.

Figure 3-29 System Properties - Data Tab

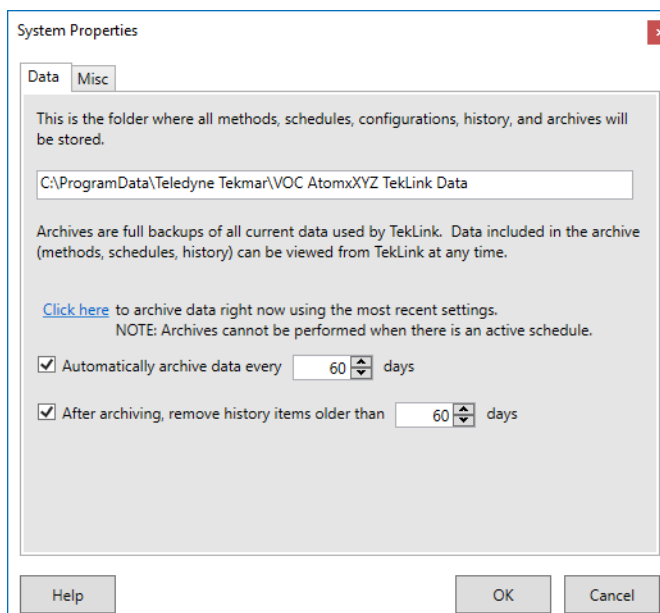

- MISCELLANEOUS TAB - The MISCELLANEOUS TAB contains a check box to enable/disable the on-screen alpha-numeric keyboard for use with a touchscreen computer.



The keyboard can be reduced and closed. If closed, it will be available again when the software is re-opened.

Figure 3-30 Figure 3-30 System Properties - Misc Tab

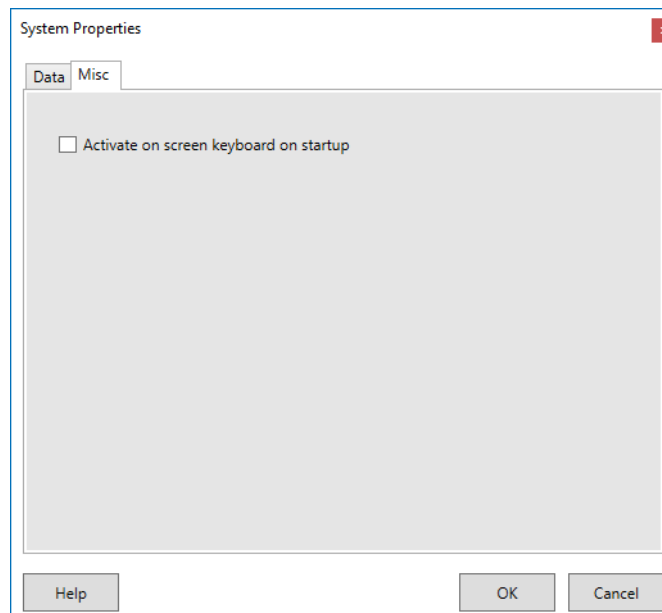

### View History Log

The VIEW HISTORY LOG displays the HISTORY LOG SCREEN. The SAMPLE HISTORY TAB, INSTRUMENT HISTORY TAB and ERROR HISTORY TAB display their respective events. Use the EVENT FILTER to refine results. When troubleshooting, information from the VIEW HISTORY LOG may be requested by a Teledyne Tekmar Customer Support Representative. Use the PRINT or EXPORT BUTTONS.

Figure 3-31 History Log - Sample History

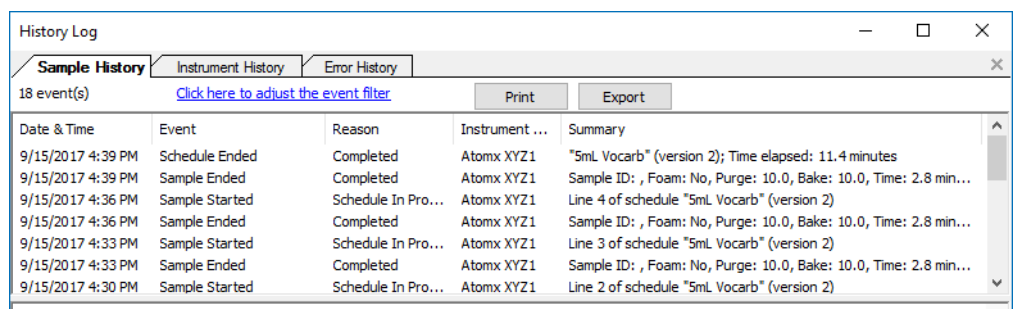

Figure 3-32 History Log - Instrument History

Date & Time	Event	Reason	Instrument ...	Summary
9/15/2017 4:39 PM	Schedule Ended	Completed	Atomx XYZ1	"5mL Vocarb" (version 2); Time elapsed: 11.4 minutes
9/15/2017 4:39 PM	Sample Ended	Completed	Atomx XYZ1	Sample ID: , Foam: No, Purge: 10.0, Bake: 10.0, Time: 2.8 min...
9/15/2017 4:36 PM	Sample Started	Schedule In Pro...	Atomx XYZ1	Line 4 of schedule "5mL Vocarb" (version 2)
9/15/2017 4:36 PM	Method Uploaded	Schedule In Pro...	Atomx XYZ1	Uploaded active method "5 mL Vocarb" version 1
9/15/2017 4:36 PM	Sample Ended	Completed	Atomx XYZ1	Sample ID: , Foam: No, Purge: 10.0, Bake: 10.0, Time: 2.8 min...
9/15/2017 4:33 PM	Sample Started	Schedule In Pro...	Atomx XYZ1	Line 3 of schedule "5mL Vocarb" (version 2)
9/15/2017 4:33 PM	Method Uploaded	Schedule In Pro...	Atomx XYZ1	Uploaded active method "5 mL Vocarb" version 1

To refine results, select **CLICK HERE TO ADJUST THE EVENT FILTER** on each tab. Events can be filtered according to:

- **SOURCE** - Select the event source (current data or archive).
- **LIMIT** - The amount of events displayed.
- **EVENT TYPE** - Restrict the events displayed by the selections.
- **EVENT REASON** - Restrict the events displayed by the selected event reasons.
- **DATE RANGE** - Omit events occurring before or after a certain date. Selecting the down arrow will display a calendar.
- **USER** - Restrict events according to the privilege levels of users.
- **INSTRUMENT PROFILE** - Restrict events according to each instrument profile.
- **SUMMARY TEXT** - Restrict events displayed according to the text entered.



Event filters can be returned to their default settings by selecting “Click here to return to the default filter for this view”.

Figure 3-33 History Log Event Filter

## Prepare for Shipment/Long-Term Shutdown

Use the PREPARE FOR SHIPMENT BUTTON to prepare the system for long-term shutdown or for packaging and safe shipment. Functions include draining all liquids from the system, sending the autosampler arm and elevator to their home positions, and providing information on properly disconnecting the instrument.

### About

The ABOUT DIALOG shows details about the Atomx XYZ TekLink software and the firmware installed on the Atomx XYZ. When troubleshooting, information from the ABOUT DIALOG may be requested by a Teledyne Tekmar Customer Support Representative.

Information in the ABOUT DIALOG can be printed by using the PRINT BUTTON at the bottom left of the dialog box.

Figure 3-34 About Dialog

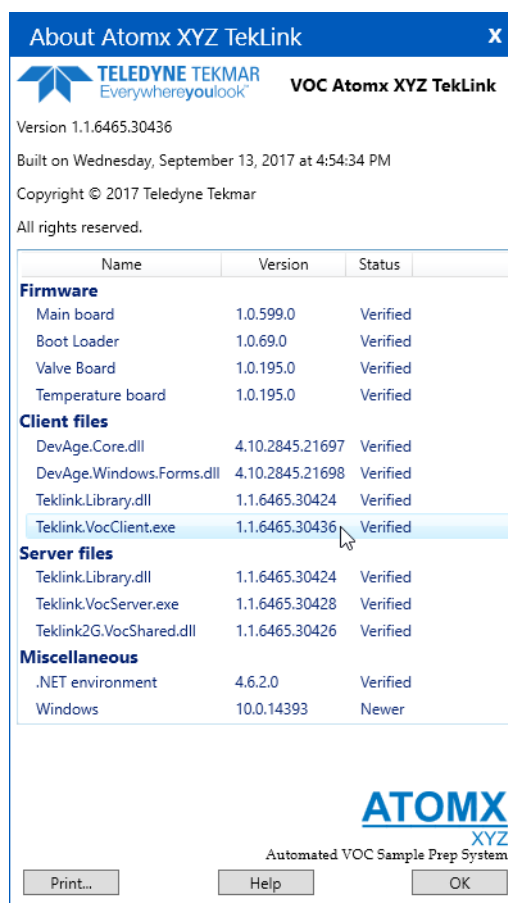



### 3.6.4 Diagnostics

#### Valves and Flows

The VALVES AND FLOWS SCREEN provides discrete control of the Atomx XYZ valves, fans, and Mass Flow Controller (MFC) for diagnostics and troubleshooting. The MFC flow rate can be manually set and the actual flow and pressure can be observed. The beeper and banner board (Instrument Status Light) can also be tested on this screen.



The Valves and Flows controls are for diagnostic and troubleshooting purposes and should only be used by someone who understands their functions. Exercise caution when manually turning on the system's valves. Damage to the instrument can result.

Figure 3-35 Diagnostics - Valves and Flows

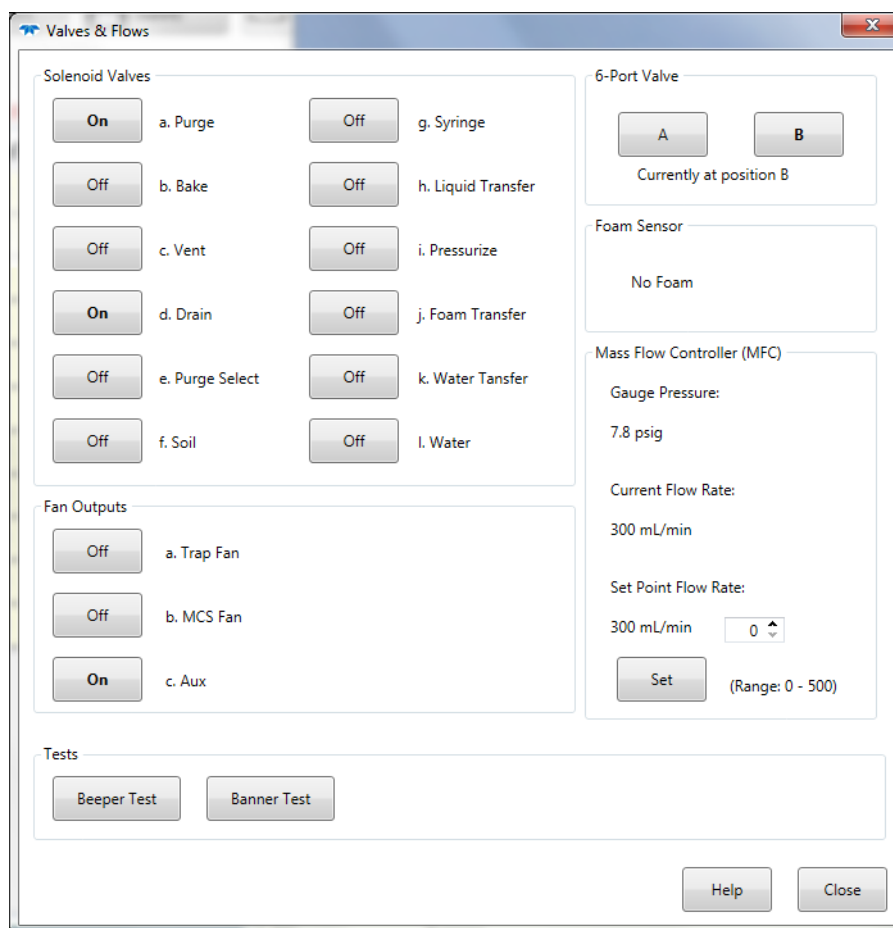

## Vial/Elevator



Use caution when using the motor diagnostic controls. Improper use can interfere with mechanical movement(s) and damage the instrument.



For the XYZ autosampler alignment procedure, refer to Section 5.16 "XYZ Autosampler Alignment".

The VIALS/ELEVATOR BUTTON displays the XYZ ARM DIAGNOSTICS SCREEN. This screen contains manual controls for moving the XYZ autosampler arms, vial gripper, vial elevator, vial mixer and dispense internal standards functions.

Figure 3-36 Vials/Elevator

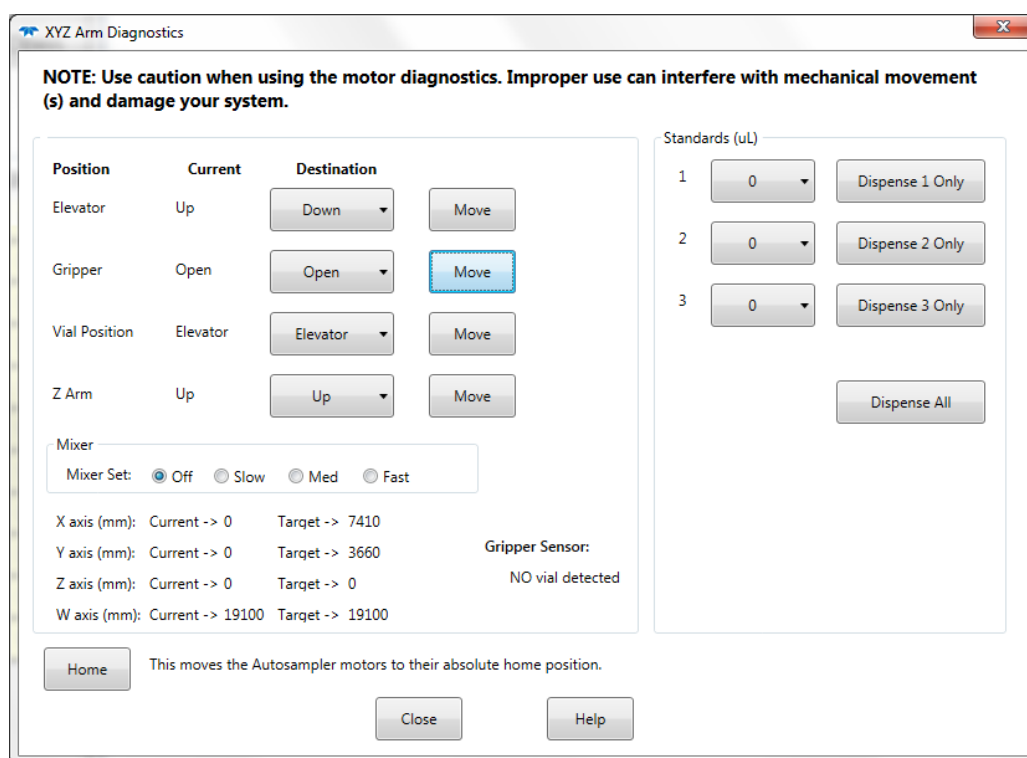

Manual controls on the dialog include:

- ELEVATOR UP/DOWN - Contains manual controls for sending the elevator to the UP, DOWN and UP (MIXING) positions.
- GRIPPER OPEN/CLOSE - Used to manually open and close the gripper. This control is frequently used to insert the alignment probe into the gripper for the autosampler alignment procedure.

- VIAL POSITION - Moves the autosampler directly to any vial position in the autosampler vial rack as well as the elevator position.
- Z-Arm Movement - Moves the autosampler Z-height arm UP or DOWN.
- HOME - Sends the autosampler arms to their absolute home position. Home position is a factory set reference location from which all other autosampler zone landmarks are based.
- STANDARDS (uL) - Manual dispensing of each or all internal standards.

### Pumper Cmd



Use caution when using the Pumper diagnostic controls. Improper use can damage the instrument.

Displays the PUMPER DIAGNOSTICS SCREEN and provides pumper, syringe and 6-port syringe valve status information as well as initialization and manual control of the syringe. Settings for syringe volume and speed are also included on this screen.

Figure 3-37 Pumper Diagnostics

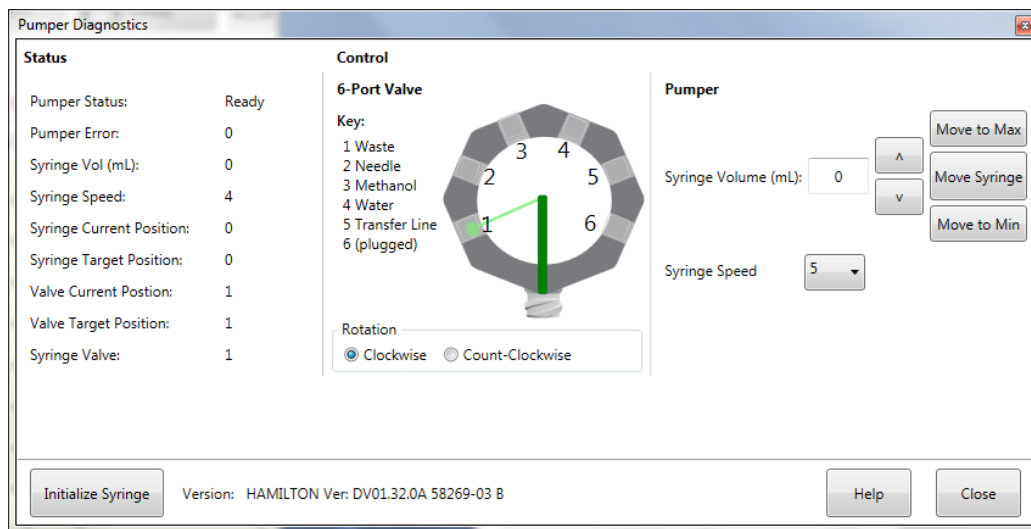

### Upgrade Firmware

The UPGRADE FIRMWARE BUTTON is used to upgrade the firmware for the system's Printed Circuit Boards (PCB). The current firmware version can be viewed via TOOLS>ABOUT BUTTON(Figure 3-34).

Figure 3-38 Upgrade Firmware Dialog

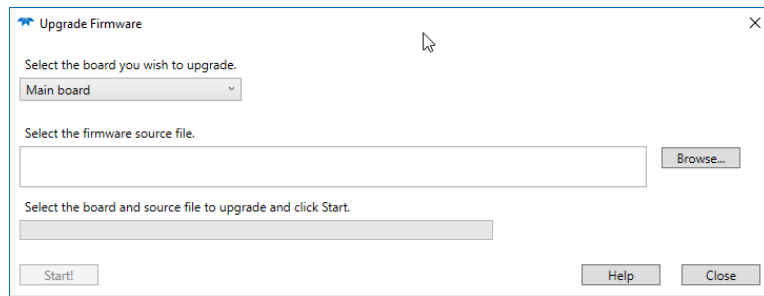

**NOTE**

For information on upgrading firmware refer to Section 5.21 "Upgrade Firmware".

**Benchmark**

The BENCHMARK BUTTON starts the BENCHMARK TEST. The BENCHMARK TEST is an interactive program that tests heaters, LEDs, and the continuity of inputs and outputs on the CPU communication board. During the test, the system will present a series of questions to the user.

The results of the test are saved in the INSTRUMENT HISTORY LOG using the name entered at the beginning of the test. To access benchmark test results select TOOLS>VIEW HISTORY LOG>INSTRUMENT HISTORY.

**NOTE**

For information on using the benchmark test function refer to Section 5.23.1 "Benchmark Test".

Figure 3-39 Benchmark Test

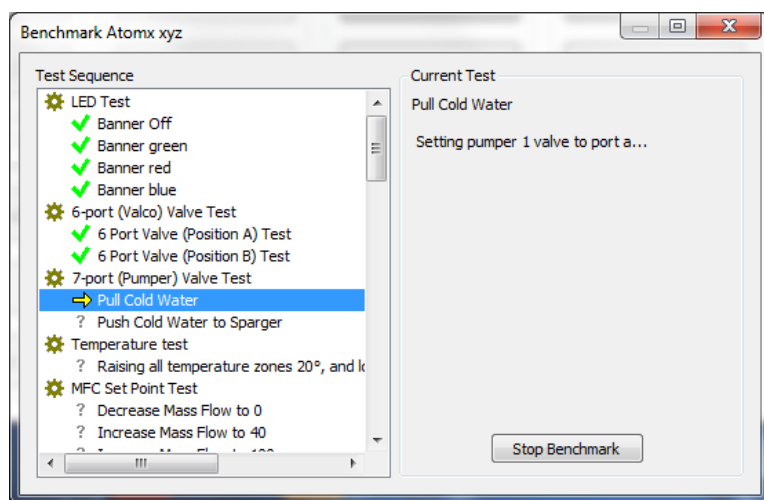

### 3.7 Add, Connect and Deactivate an Instrument Profile

After software installation, TekLink will prompt to create an instrument profile. Once an instrument profile is created, it cannot be deleted or over-written, but can be “deactivated”. To create an instrument profile and connect to it, or deactivate an instrument profile, follow the procedures below.



#### NOTE

All methods, schedules, and TekLink software configurations/settings are profile specific.

#### 3.7.1 Add an Instrument Profile and Connect



#### NOTE

When creating a new instrument profile on a single instrument configuration, the current instrument profile must first be deactivated. Refer to Section 3.7.2 "Deactivate an Instrument Profile".



#### NOTE

When adding a new instrument profile on a multi-instrument configuration, ensure all instruments are connected to the controlling computer in order for Atomx XYZ TekLink to recognize their USB connections. If only one USB connection is present, TekLink will prohibit the creation of an additional profile.

1. On the **TOOLS SCREEN** select the **INSTRUMENT MANAGER BUTTON** to display the **INSTRUMENT MANAGER DIALOG**.
2. Select the **ADD BUTTON** to display the **CONFIGURATION DIALOG**. Complete the following in the **CONFIGURATION DIALOG**:

On the **GENERAL TAB**:

- Enter a name for the instrument profile. If there are other Atomx XYZ instruments on the network, use the name and description to differentiate one from another.
- Enter a description that easily identifies the instrument.

Figure 3-40 Creating an Instrument Profile

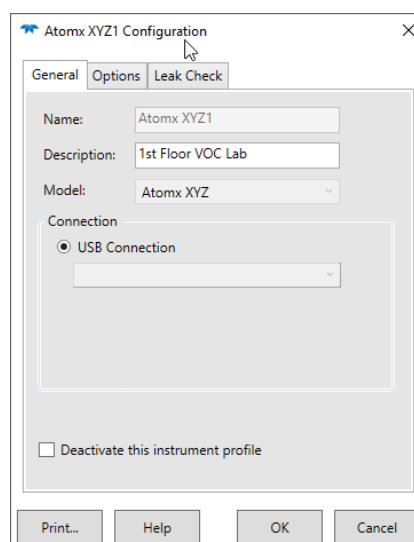

- Select the default USB CONNECTION check-box.

On the OPTIONS TAB:

- If you would like the software to notify you of errors, enable the beeper option.
- If an optional Guardian Foam and/or Eliminator is installed, place a check mark in the selection box. Choose the exact configuration from the drop-down menu.
- Select the appropriate purge gas from the PURGE GAS DROP-DOWN MENU.
- Select the Gas CHROMATOGRAPH (GC TYPE) from the GC MODEL DROP-DOWN MENU. If the specific model of the GC is not shown in the drop-down menu, use the STANDARD TYPE:63 or USER TYPE:31 check-box according to the GC manufacturer's *User Manual* instructions.

Figure 3-41 Options Tab

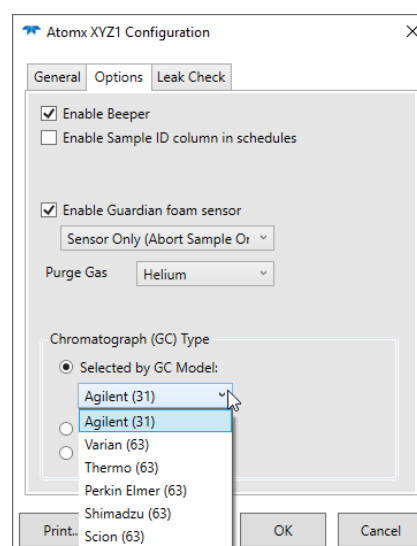

On the LEAK CHECK TAB:

- Customize LEAK CHECK PRESSURIZE TIME, LEAK CHECK FLOW and LEAK CHECK DELTA, or use the default settings.

Figure 3-42 Leak Check Tab

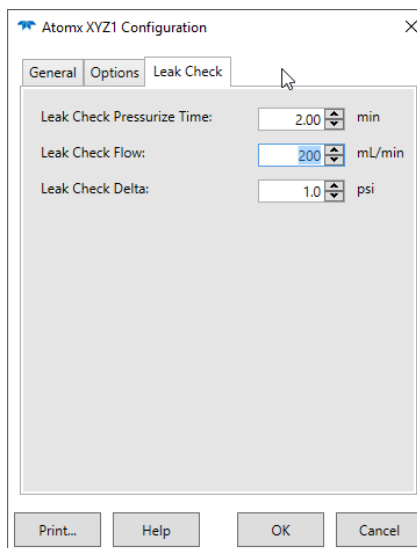

3. Select the OK BUTTON to create the new instrument profile. The new profile will now be shown in the INSTRUMENT MANAGER. If this is the first instrument profile created, it will automatically become the default profile. If other profiles exist and the new profile is to be the “default” profile, ensure the DEFAULT RADIO BUTTON is selected.
4. To connect to the new profile, highlight the profile and then select the CONNECT BUTTON. Once connected, a check mark will appear in the CONNECTED CHECK BOX beside the profile and the INSTRUMENT STATUS PANEL, METHODS SCREEN and SCHEDULES SCREEN will display the connected instrument profile name. Methods, schedules, system properties, and preferences will now be saved to that profile.

### 3.7.2 Deactivate an Instrument Profile

Instrument profiles cannot be deleted, only “deactivated”. When an instrument profile has been deactivated it will not show in the selection of instrument profiles available via TOOLS>INSTRUMENT MANAGER (unless the SHOW DEACTIVATED INSTRUMENT PROFILES CHECK-BOX is selected in that dialog). To connect to a deactivated instrument profile, deselect the DEACTIVATE THIS INSTRUMENT PROFILE CHECK BOX in the profile’s PROPERTIES/CONFIGURATION DIALOG. The previously deactivated profile will then be shown in the INSTRUMENT MANAGER. Highlight the profile and then select the CONNECT BUTTON.

To deactivate an instrument profile:

1. From the HOME SCREEN select the TOOLS BUTTON.
2. On the TOOLS SCREEN select the CONFIGURATION BUTTON to display the CONFIGURATION DIALOG.



Figure 3-43 Configuration Dialog Showing Current Instrument Profile

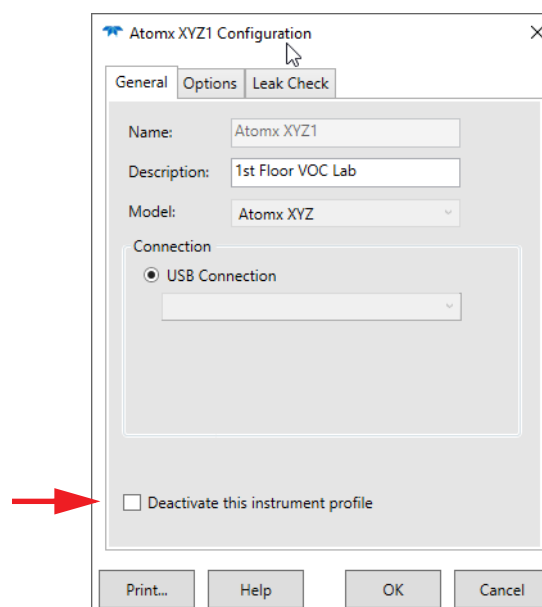

3. Place a check-mark in the DEACTIVATE THIS INSTRUMENT PROFILE check-box.
4. Select the OK BUTTON to save the change.

## 3.8 Using the Methods Screen

### 3.8.1 Methods Types

When the METHODS BUTTON is selected on the HOME SCREEN, TekLink will prompt for a choice of method types (WATER, SOIL, or METHANOL EXTRACTION). Once the selection is made, the parameters on the STANDBY, PURGE, DESORB, and BAKE TABS will be configured according to the type of analysis. The default values shown for each parameter are good starting points for successful analysis, and can be used as the foundation of a user-defined custom method.

The method “template” displayed once the “method type” is selected should not be confused with TekLink’s default water, soil, or methanol methods. The method template must be given a name and saved, prior to loading it to the instrument.

### 3.8.2 Default Methods

To use the default water, soil or methanol method provided with Atomx XYZ TekLink, open it from the METHODS SCREEN or select it from the SCHEDULES SCREEN METHOD DROP-DOWN. Refer to Section 3.8.3 "Open a Method" and Section 3.9 "Using the Schedule Screen". The default method can then be loaded from either screen.

### 3.8.3 Open a Method

Open a default, custom or archived method:

1. Select the METHODS BUTTON on the HOME SCREEN to open the METHODS SCREEN.
2. When prompted, choose the method type.
3. Select the OPEN BUTTON on the METHODS SCREEN then use the SOURCE DROP-DOWN MENU to select the CURRENT or ARCHIVED method. The INSTRUMENT STATUS PANEL and the title bar on the METHODS and SCHEDULES SCREENS will display the opened method.



Custom methods are specific (saved) to each Instrument Profile and cannot be opened from other instrument profiles.

### 3.8.4 Creating a Custom Method



For information on developing a method refer to 4.3 "Optimization/Method Development".



A default water, soil or methanol extraction method cannot be overwritten. If it is revised, it must be saved under a different name prior to loading it to the instrument. Custom methods are specific (saved) to each Instrument Profile and cannot be opened from other instrument profiles.

1. From the HOME SCREEN select the METHODS BUTTON. The CHOOSE METHOD TYPE DIALOG will be shown.
2. Select a WATER, SOIL or METHANOL EXTRACTION method type. Once the selection is made, the parameters on the STANDBY, PURGE, DESORB, and BAKE TABS will be configured according to the type of sample and the icon, color, and title in the header of the screen will change.

Figure 3-44 Choose Method Type

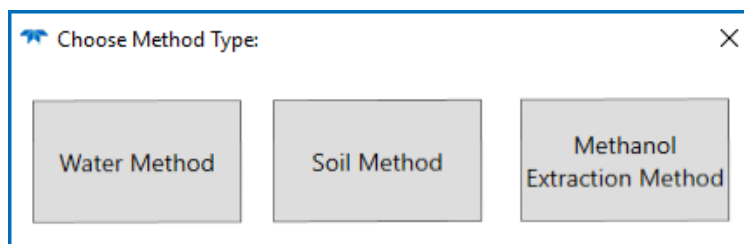

Figure 3-45 Methods Screen Water, Soil, and Methanol Extraction Headers

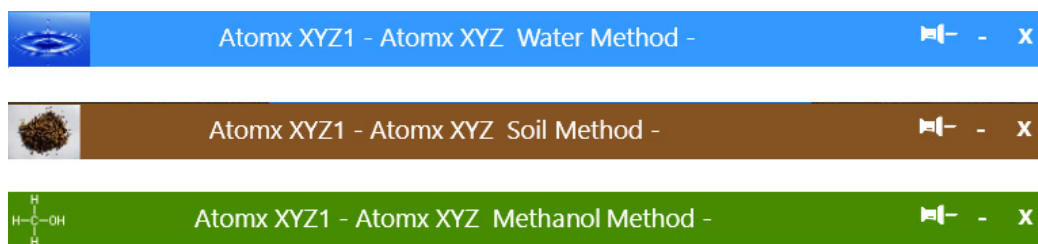
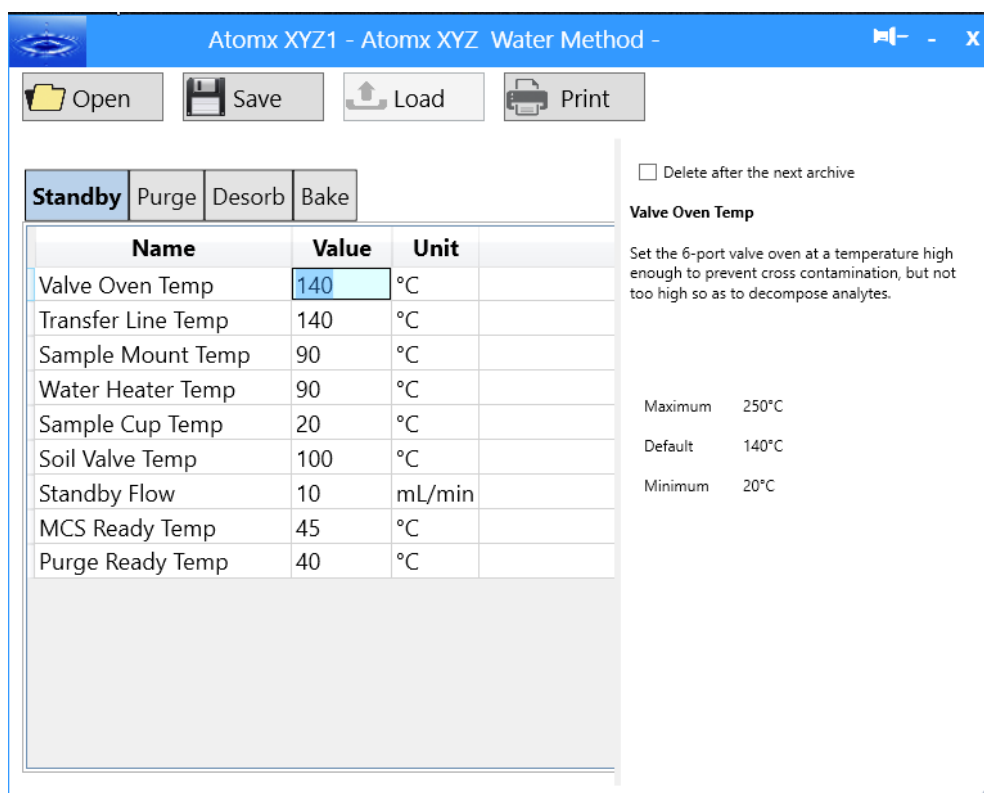

Figure 3-46 Waters Methods Screen - Water Method



3. Modify parameters on the STANDBY, PURGE, DESORB, and BAKE TABS by double-clicking in the VALUE COLUMN and inputting the parameter values.



For information on parameters of note refer to Section 3.4 "Methods Screen". Also refer to Section 4.4 "Method Parameters".

- Save the new method by selecting the SAVE BUTTON. Name the method, then select the OK BUTTON.



Note that the title bar on the Methods Screen updates with the method name.

Figure 3-47 Save Method As Dialog

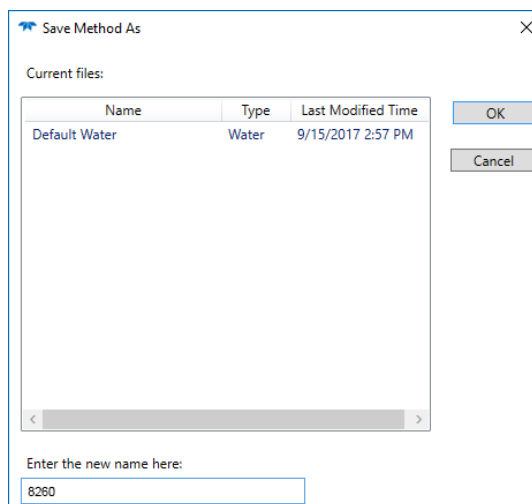

↑  
**Name Method**

Figure 3-48 New Method Saved - Name in Title Bar

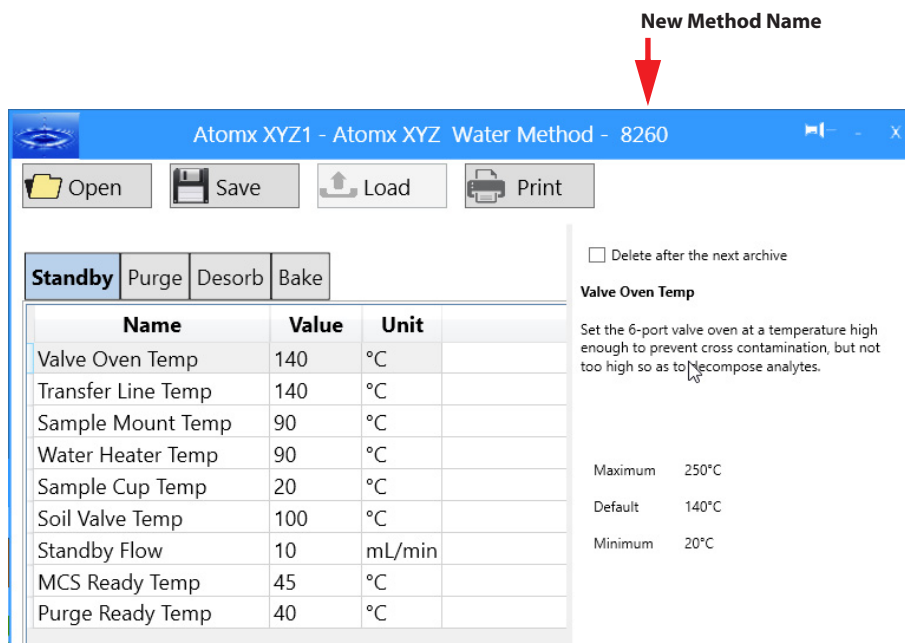

### 3.8.5 Load the Method

Select the LOAD METHOD BUTTON to prompt the Atomx XYZ to begin using method parameters immediately. After temperature set-points are reached, the system will go into standby/purge ready. If the method is not loaded from the METHODS SCREEN, it will be loaded (if selected from the METHOD DROP-DOWN) when the schedule is loaded from the SCHEDULES SCREEN.

### 3.8.6 Print a Method

Use the PRINT BUTTON on the METHODS SCREEN to print the current or completed method. A PRINT DIALOG will be displayed.

## 3.9 Using the Schedule Screen

### 3.9.1 Open Schedule

Use the OPEN BUTTON on the SCHEDULES SCREEN to open an existing or archived schedule. Use the SOURCE DROP-DOWN MENU to select the CURRENT or appropriate ARCHIVED schedule.

### 3.9.2 Create a Schedule



#### NOTE

The schedule is created using a combination of manual entries, drop-down menus and right-click options on each line. Right-click options are a particularly simple way to create and revise schedule lines.

1. If necessary, connect to the appropriate instrument profile. The current instrument profile is shown on the INSTRUMENT STATUS PANEL and the title bar of the METHODS and SCHEDULES SCREENS. Refer to Section 3.7.1 "Add an Instrument Profile and Connect".



#### NOTE

Custom methods and schedules are specific (saved) to each Instrument Profile and cannot be opened from other instrument profiles.

2. From the HOME SCREEN select the SCHEDULES BUTTON to display the SCHEDULES SCREEN.

Figure 3-49 Schedules Screen - Blank Schedule

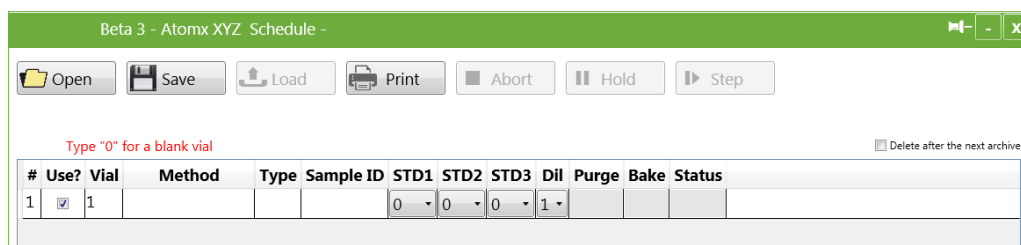

1. To add additional lines to the SCHEDULE TABLE:
  - Click in the current schedule line and then use the down arrow key.
  - Right-click on the current schedule line and select INSERT NEW LINE (ABOVE or BELOW) (Figure 3-50).
2. Easily fill in incrementing vials using the fill down command.
  - Highlight a cell or an entire schedule line and then drag down or up to highlight other lines. Right-click and choose FILL DOWN or FILL UP to auto-fill the other lines (Figure 3-50).
  - Vial Positions will increment while blanks, method and standard choices will auto-fill. When blanks are added, the vial numbers will increment around them.

Figure 3-50 Schedules Screen Right-Click Options

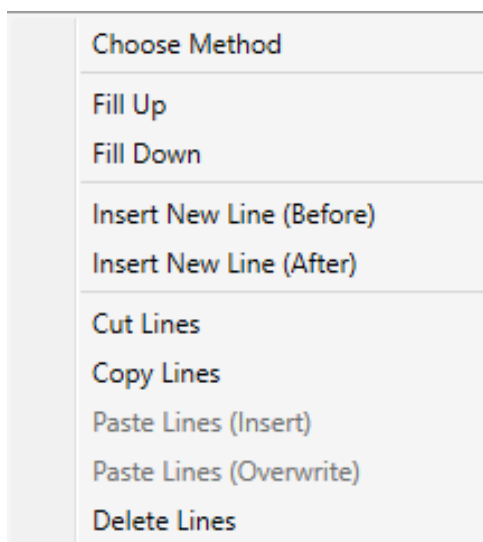

3. Fill in the criteria for each cell of the schedule line:
  - USE Column - Select or deselect the USE CHECK-BOX to include/exclude the schedule line from the current schedule. The use check-box is an easy way to modify a previously created schedule.
  - VIAL - The VIAL COLUMN auto-increments as schedule lines are added. Add a blank to the schedule by entering zero in the VIAL COLUMN and pressing <Enter>. The zero will turn to BLK indicating a blank in the schedule line selected (Line 1 in Figure 3-51). Alternatively right-click in the VIAL COLUMN and select USE BLANK INSTEAD OF VIAL.

Figure 3-51 Zero in Vial Column Becomes Blank

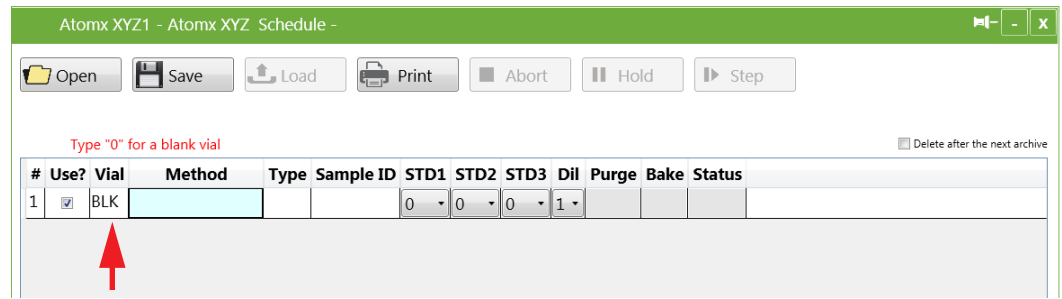

- **METHOD** - Double-click in the METHOD COLUMN to display the OPEN METHOD DIALOG. Alternatively, right-click in the METHOD COLUMN and select CHOOSE METHOD to display the OPEN METHOD DIALOG. Select the source of the method to open (CURRENT or ARCHIVED), highlight the method and then select the OK BUTTON.
- **TYPE** - The TYPE COLUMN auto-fills according to the method type selected.

Figure 3-52 Select Method Dialog

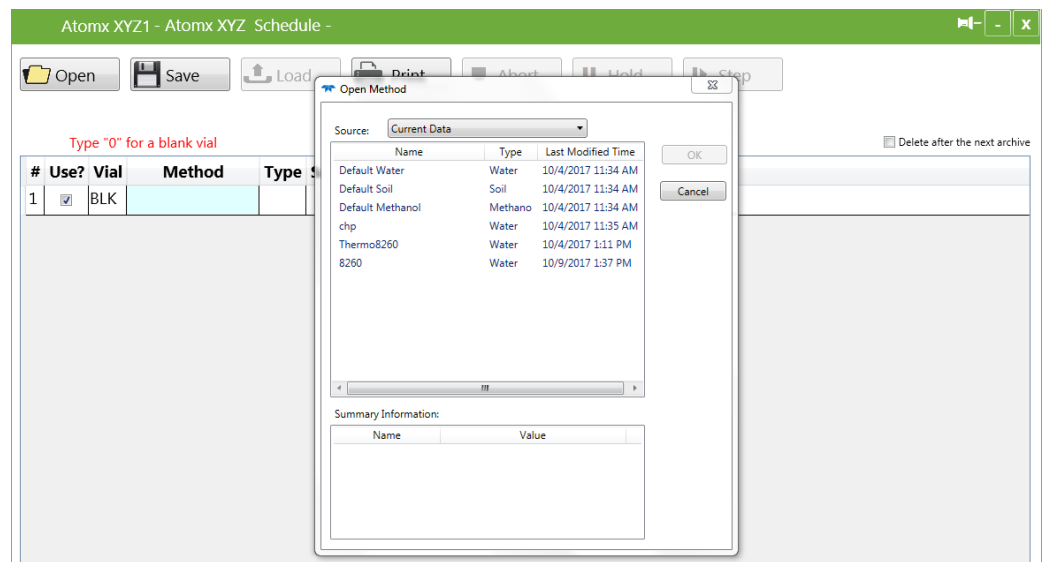

- **SAMPLE ID (Optional)** - The SAMPLE ID column is optional and is configured on the INSTRUMENT CONFIGURATION SCREEN via TOOLS>CONFIGURATION BUTTON. Enter a sample ID in the field.

Figure 3-53 Sample ID Column

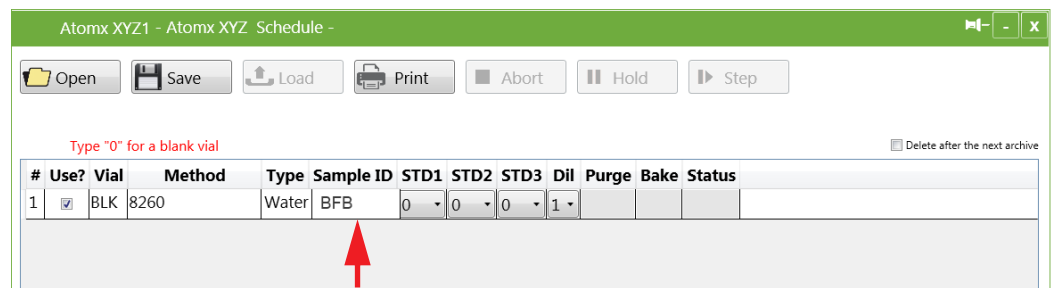

- STD1, 2, 3 - Add internal standards or a matrix spike (methanol extraction) to the Schedule - Add a standard by double-clicking in the STD1, STD2 and/or STD3 cells. Select the standard volume (in µL) from the drop-down menu.

Figure 3-54 Select Standard Drop-Down

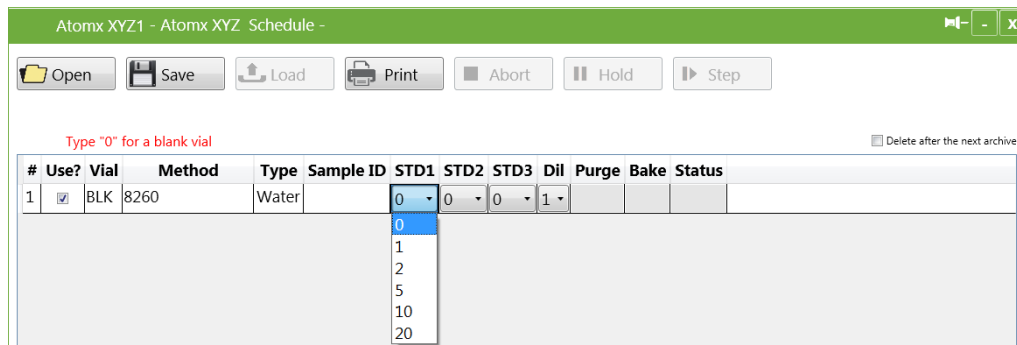

**NOTE**

If a methanol extraction method is chosen, STD3 is reserved for an in-vial matrix spike.

- DIL (Dilutions) - If the sample is to be diluted, select the dilution ratio from the DILUTION DROP-DOWN MENU.
- For information on the PURGE, BAKE, FOAM and STATUS COLUMNS refer to Section 3.5 "Schedules Screen".

### 3.9.3 Save Schedule

While building the schedule, or after it is fully constructed, use the SAVE BUTTON to save the active schedule. The SAVE BUTTON will display the SAVE SCHEDULE AS DIALOG where a name for the schedule can be entered. Select the OK BUTTON to save the schedule.

Figure 3-55 Save Schedule

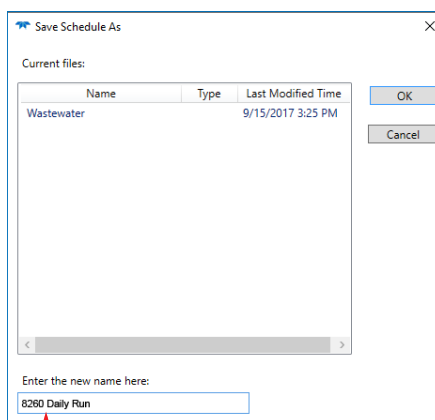

**Name Schedule**



### 3.9.4 Print Schedule

Use the PRINT BUTTON on the SCHEDULES SCREEN to print the current or completed schedule. A PRINT DIALOG will be displayed.

### 3.9.5 Load (Run) the Schedule

To run the schedule, select the LOAD BUTTON on the SCHEDULES SCREEN. If the method selected in the schedule's METHOD DROP-DOWN FIELD was not previously loaded from the METHODS SCREEN, it will be loaded when the schedule is loaded and the Atomx XYZ will begin using those method parameters.

Once the schedule is loaded, the schedule's STATUS COLUMN will update to PENDING, indicating that the system is heating to temperature set-points. The INSTRUMENT STATUS PANEL will update with the current mode, time, and action.

Figure 3-56 Schedule Loaded

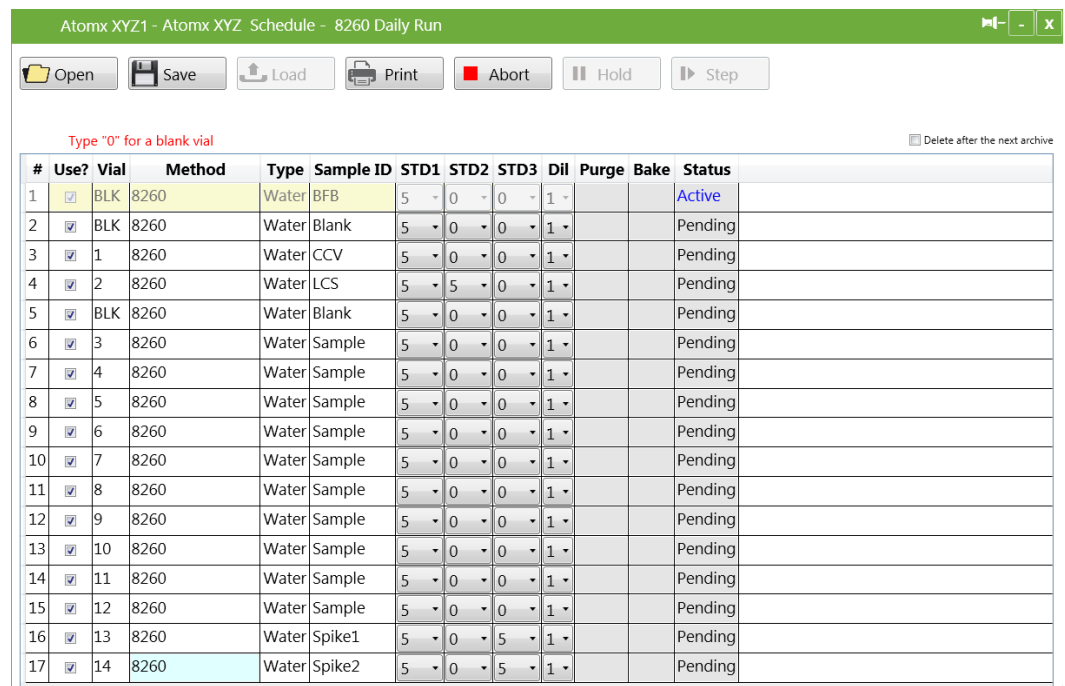

Type "0" for a blank vial  Delete after the next archive

#	Use?	Vial	Method	Type	Sample ID	STD1	STD2	STD3	Dil	Purge	Bake	Status
1	<input checked="" type="checkbox"/>	BLK	8260	Water	BFB	5	0	0	1			Active
2	<input checked="" type="checkbox"/>	BLK	8260	Water	Blank	5	0	0	1			Pending
3	<input checked="" type="checkbox"/>	1	8260	Water	CCV	5	0	0	1			Pending
4	<input checked="" type="checkbox"/>	2	8260	Water	LCS	5	5	0	1			Pending
5	<input checked="" type="checkbox"/>	BLK	8260	Water	Blank	5	0	0	1			Pending
6	<input checked="" type="checkbox"/>	3	8260	Water	Sample	5	0	0	1			Pending
7	<input checked="" type="checkbox"/>	4	8260	Water	Sample	5	0	0	1			Pending
8	<input checked="" type="checkbox"/>	5	8260	Water	Sample	5	0	0	1			Pending
9	<input checked="" type="checkbox"/>	6	8260	Water	Sample	5	0	0	1			Pending
10	<input checked="" type="checkbox"/>	7	8260	Water	Sample	5	0	0	1			Pending
11	<input checked="" type="checkbox"/>	8	8260	Water	Sample	5	0	0	1			Pending
12	<input checked="" type="checkbox"/>	9	8260	Water	Sample	5	0	0	1			Pending
13	<input checked="" type="checkbox"/>	10	8260	Water	Sample	5	0	0	1			Pending
14	<input checked="" type="checkbox"/>	11	8260	Water	Sample	5	0	0	1			Pending
15	<input checked="" type="checkbox"/>	12	8260	Water	Sample	5	0	0	1			Pending
16	<input checked="" type="checkbox"/>	13	8260	Water	Spike1	5	0	5	1			Pending
17	<input checked="" type="checkbox"/>	14	8260	Water	Spike2	5	0	5	1			Pending

Figure 3-57 Instrument Status Panel Updated

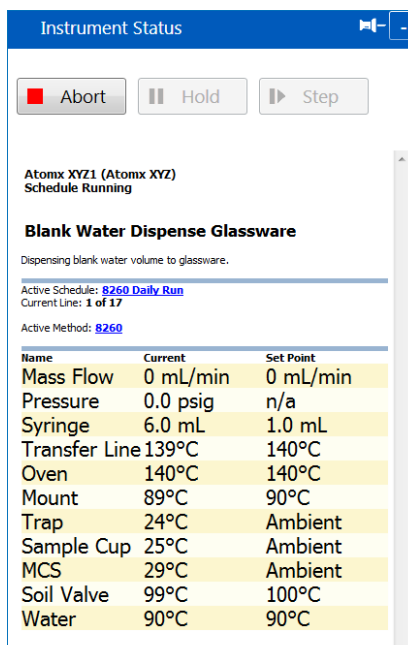

### 3.9.6 Step Schedule

Use the STEP BUTTON to sequentially move through each of the system’s modes. When using the STEP BUTTON, use the INSTRUMENT STATUS PANEL to view the current mode.

### 3.9.7 Hold Schedule

Once the schedule has been loaded, the HOLD BUTTON on the SCHEDULES SCREEN and INSTRUMENT STATUS PANEL can be used to hold the schedule at its current position. When selected, the HOLD BUTTON will change to an AUTO BUTTON. Select the AUTO BUTTON to resume the schedule.

Figure 3-58 Schedule Hold - Instrument Status Panel

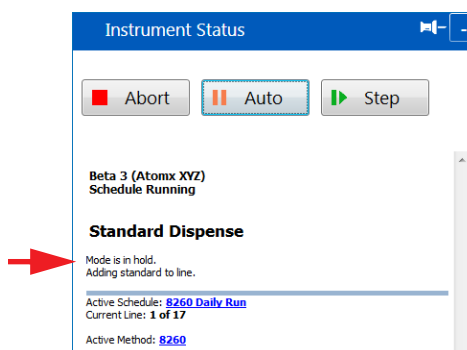

### 3.9.8 Abort a Sample or Schedule

1. To abort a single sample or entire schedule use the ABORT BUTTON on the SCHEDULES SCREEN or the INSTRUMENT STATUS PANEL.
2. Once aborted, Atomx XYZ TekLink will ask if the abort command is for:
  1. The ENTIRE SCHEDULE
  2. The CURRENT SAMPLE ONLY
  3. The ENTIRE SCHEDULE AFTER CURRENT SAMPLE

Figure 3-59 Abort Dialog

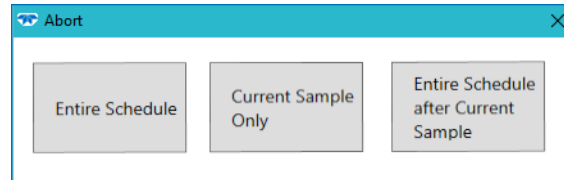

3. Once the type of abort has been selected, Atomx XYZ TekLink will prompt to confirm the abort command using the CONFIRM BUTTON on the SCHEDULES SCREEN or the INSTRUMENT STATUS PANEL.

Figure 3-60 Confirm Selected, Schedule Aborted

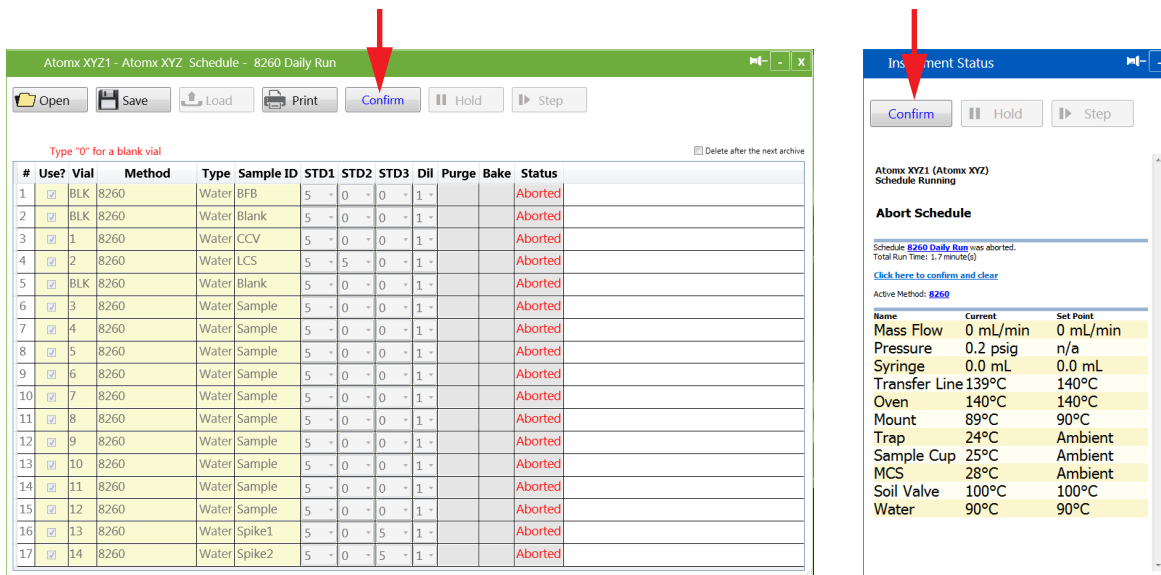

### 3.9.9 Completion of the Schedule

Once the active schedule has been completed, the SCHEDULE SCREEN and INSTRUMENT STATUS SCREEN will display a CONFIRM BUTTON. Confirming the schedule's completion will clear the active schedule and allow another schedule to be run. The active method will continue until another method is loaded.

### 3.10 Data Storage Location and Archiving Data

Archives are full backups of all data used by Atomx XYZ TekLink including method, schedule, configuration, history and archives. The data is stored in C:\ProgramData\Teledyne Tekmar\VOC AtomxXYZ TekLink Data by default, and cannot be changed.

1. To archive data immediately or to designate an interval for archiving data, select the TOOLS BUTTON>SYSTEM PROPERTIES>DATA TAB.
2. Archive data immediately by selecting “[CLICK HERE TO ARCHIVE DATA RIGHT NOW USING THE MOST RECENT SETTINGS](#)” or schedule regular intervals for archiving information.

Figure 3-61 System Properties - Data Tab

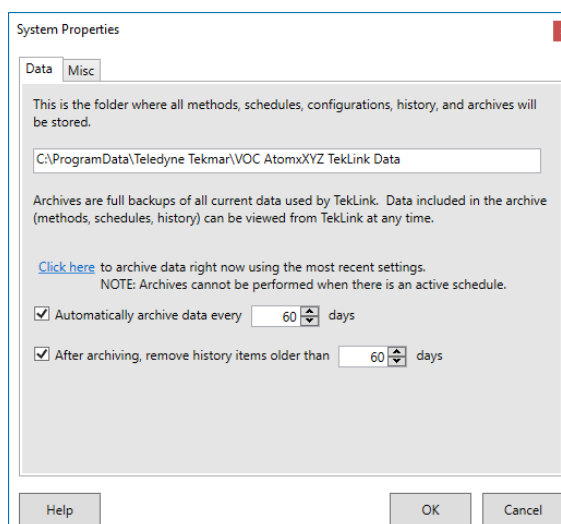

 **NOTE**

Data cannot be archived when a schedule is running.

Archived schedule and methods can be viewed by using the OPEN BUTTON on the respective screen and selecting the ARCHIVE in the SOURCE DROP-DOWN MENU. SAMPLE, INSTRUMENT and ERROR HISTORY can be viewed by changing the FILTER settings on the HISTORY LOG (TOOLS>VIEW HISTORY LOG).

Figure 3-62 Open Schedule Dialog - Source Drop-down

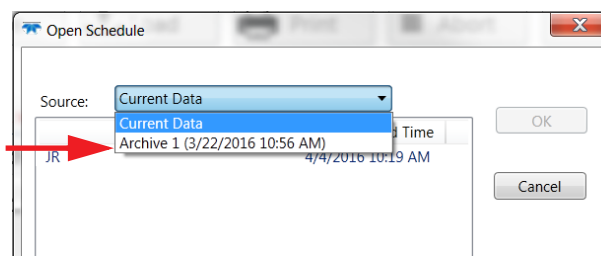

# Atomx XYZ User Manual

## Chapter 4: Instrument Operations

### 4.1 Atomx XYZ Mode Descriptions

The Atomx XYZ performs a programmed series of operating steps. These steps are referred to as modes and vary depending on system configuration. Mode descriptions are provided in Table 4-1 "Mode Descriptions".



#### NOTE

For Flow Diagrams for each mode, refer to Appendix A: "Diagrams".

**Table 4-1 Mode Descriptions**

Mode	Description
Standby	This mode indicates that the system is waiting for all temperature zones and flow rates to reach their set-points.
Purge Ready	This mode indicates all method set points are at equilibrium and the system is ready to analyze samples.
Sample Fill	This mode allows an aliquot to be removed from the sample vial by the syringe.
Standard Dispense	This mode allows standard to be added to the sample pathway for transfer to the sparge vessel with the sample. The standards can also be dispensed to the vial for soil purges or used as a Matrix Spike prior to a Methanolic extraction.
Sample Transfer	This mode indicates that a liquid sample is being introduced into the sparging vessel.
Prepurge	When the Atomx XYZ is working in conjunction with an external sample heater, this mode directs purge gas to the vessel to remove excess oxygen prior to heating and subsequent purging.
Preheat Purge	When the Atomx XYZ is working in conjunction with the sparge vessel heater, this mode allows the sample to reach a uniform programmed temperature, prior to sample purging.
Purge	This is a VOC extraction mode in which the inert gas (such as helium) is dispersed through the sample matrix in the sparger (or in the sample vial if a soil) for a preset time and flow. The gas containing the analytes is directed to an analytical trap for concentration. <b>Note:</b> <i>The gas passes through the trap, deposits the analytes, and is vented to the atmosphere.</i>
Dry Purge	This mode is used to drive excess water from the analytical trap. The inert gas is directed to the analytical trap without passing through the sample glassware. This process ensures that no additional moisture is added to the trap.
Desorb Ready	This mode indicates that the system is waiting for a GC ready signal to allow it to step to Desorb.
Desorb Preheat	This mode heats the analytical trap to a preset temperature in a static state, allowing the analytes to release from the sorbent material.
Desorb	This mode heats the analytical trap to its final temperature and rotates the 6-port valve so that the carrier gas is back-flushed through the trap in order to carry VOCs to the GC for separation and detection. This mode will also start the GC column program.

**Table 4-1 Mode Descriptions (Continued)**

<b>Mode</b>	<b>Description</b>
Bake Rinse	This mode introduces hot water into the sparger for syringe, glassware and tubing rinsing, cleaning the system between samples.
Bake Drain	This mode drains the water, introduced to the sample glassware during the Bake Rinse Mode, from the system.
Bake	This mode sweeps the sample pathway and the analytical trap, which is being held at a high temperature, with dry purge gas to clean the system between samples.
Methanol Rinse	This mode allows methanol to be introduced into the sparger for syringe, glassware and line rinsing, to clean the system between samples.
Methanol Rinse Drain	This mode drains the methanol, introduced to the sample glassware during the Methanol Rinse Mode, from the system.

## 4.2 Atomx XYZ Valve Output/Mechanism Chart

### 4.2.1 Waters

Mode	Valves														Mechanisms								
	Purge	Bake	Vent	Drain	Purge Select	Soil	Syringe	Liquid Transfer	Pressurize	Foam Transfer	Water Transfer	Water	S#1	S#2	S#3	6-port Syringe Valve	6-port direction	Valco 6-port	MFC	Arm	Elevator	Mixer	
Standby	off	on	off	on	on	off	off	off	off	off	off	off	off	off	off	1	na	A	stdby flow	home	dn	off	off
Purge Ready	off	on	off	on	on	off	off	off	off	off	off	off	off	off	off	1	na	A	stdby flow	home	up	off	off
Pre Sweep A	off	on	off	on	on	off	off	on	off	off	off	off	off	off	off	2	cw	A	stdby flow	home	up	off	off
Pre Sweep B	off	on	off	on	on	off	off	on	off	off	off	off	off	off	off	5	ccw	A	stdby flow	home	up	off	off
Move Vial	off	on	off	on	on	off	off	off	off	off	off	off	off	off	off	1	cw	A	stdby flow	position	home	off	off
Raise Vial	off	on	off	on	on	off	off	off	off	off	off	off	off	off	off	1	na	A	stdby flow	home	up	off	off
Sample Equilibrate	off	on	off	on	on	off	off	off	off	off	off	off	off	off	off	1	na	A	stdby flow	home	up	off	off
Prime Sample Fill	off	on	off	on	on	off	off	off	off	off	off	off	off	off	off	2	cw	A	stdby flow	home	up	off	off
Prime Sample Dispense	off	on	off	on	on	off	off	off	off	off	off	off	off	off	off	1	ccw	A	stdby flow	home	up	off	off
Sample Fill	off	on	off	on	on	off	off	off	off	off	off	off	off	off	off	2	cw	A	stdby flow	home	up	off	off
Sample Dispense-Waste1	off	on	off	on	on	off	off	off	off	off	off	off	off	off	off	1	ccw	A	0	home	up	off	off
Std Dispense	off	off	on	on	on	off	on	off	off	off	off	off	on	on	on	1	na	A	0	home	up	off	off
Sample Dispense-Glassware	off	off	on	off	on	off	on	off	off	off	off	off	off	off	off	5	ccw	A	0	home	up	off	off
Sample Dispense-Waste2	off	off	on	off	on	off	on	off	off	off	off	off	off	off	off	1	cw	A	0	home	up	off	off
Sweep Waste	off	off	on	off	on	off	on	on	on	on	on	on	off	off	off	1	na	A	0	home	up	off	off
Sweep Sample	on	off	on	off	on	off	on	on	off	off	off	off	off	off	off	5	ccw	A	swp smpl flow	home	up	off	off
Prime Sample Fill (Dil)	off	on	off	on	on	on	off	off	off	off	off	off	off	off	off	2	cw	A	0	home	up	off	off
Prime Sample Dispense (Dil)	off	on	off	on	on	on	off	off	off	off	off	off	off	off	off	1	ccw	A	0	home	up	off	off
Sample Fill (Dil)	off	on	off	on	on	on	off	off	off	off	off	off	off	off	off	2	cw	A	0	home	up	off	off
Sample Dispense-Waste1 (Dil)	off	on	off	on	on	off	off	off	off	off	off	off	off	off	off	1	ccw	A	0	home	up	off	off
STD Dispense (Dil)	off	off	on	on	on	off	on	off	off	off	off	off	on	on	on	1	na	A	0	home	up	off	off
Sample Dispense-Glassware (Dil)	off	off	on	off	on	off	on	off	off	off	off	off	off	off	off	5	ccw	A	0	home	up	off	off
Sample Dispense-Waste2 (Dil)	off	off	on	off	on	off	on	off	off	off	off	off	off	off	off	1	cw	A	0	home	up	off	off
Sample Sweep Waste (Dil)	off	off	on	off	on	off	on	on	on	on	on	on	off	off	off	1	na	A	0	home	up	off	off
Sweep Sample (Dil)	on	off	on	off	on	off	on	on	off	off	off	off	off	off	off	5	ccw	A	swp smpl flow	home	home	off	off
DI Rinse Fill (Dil)	off	off	on	off	on	off	on	off	off	off	off	off	off	off	off	4	ccw	A	0	home	home	off	off
DI Rinse Dispense (Dil)	off	off	on	off	on	off	off	off/on	off	off	off	off	off	off	off	1	ccw	A	0	home	home	off	off
DI Fill (Dil)	off	off	on	off	on	off	off	off	off	off	off	off	off	off	off	4	cw	A	0	home	home	off	off
DI Dispense waste (Dil)	off	off	on	off	on	off	on	off	off	off	off	off	off	off	off	1	ccw	A	0	home	home	off	off
DI Transfer (Dil)	off	off	on	off	on	off	on	off	off	off	off	off	off	off	off	5	ccw	A	0	home	home	off	off
DI Sweep Waste (Dil)	off	off	on	off	on	off	on	on	on	on	on	on	off	off	off	1	cw	A	0	home	home	off	off
Sweep DI (Dil)	on	off	on	off	on	off	on	on	off	off	off	off	off	off	off	5	ccw	A	swp smpl flow	home	home	off	off



### Waters (Continued)

Mode	Valves													Mechanisms									
	Purge	Bake	Vent	Drain	Purge Select	Soil	Syringe	Liquid Transfer	Pressurize	Foam Transfer	Water Transfer	Water	IS #1	IS #2	IS #3	6-port Syringe Valve	6-port direction	Valco 6-port	MFC	Arm	Elevator	Mixer	
Purge	on	off	on	off	off	off	off	off	off	off	off	off	off	off	off	off	off	off	off	off	off	off	off
Raise Elevator	on	off	on	off	off	off	off	off	off	off	off	off	off	off	off	off	off	off	off	off	off	off	off
MeOH Rinse Syringe/Needle Dispense I	on	off	on	off	off	off	off	off	off	off	off	off	off	off	off	off	off	off	off	off	off	off	off
MeOH Rinse Syringe/Needle Dispense II	on	off	on	off	off	off	off	off	off	off	off	off	off	off	off	off	off	off	off	off	off	off	off
MeOH Rinse Syringe/Needle Dispense III	on	off	on	off	off	off	off	off	off	off	off	off	off	off	off	off	off	off	off	off	off	off	off
Rinse Syringe Fill I	on	off	on	off	off	off	off	off	off	off	off	off	off	off	off	off	off	off	off	off	off	off	off
Rinse Syringe/Needle Dispense I	on	off	on	off	off	off	off	off	off	off	off	off	off	off	off	off	off	off	off	off	off	off	off
Rinse Syringe Fill II	on	off	on	off	off	off	off	off	off	off	off	off	off	off	off	off	off	off	off	off	off	off	off
Rinse Syringe/Needle Dispense II	on	off	on	off	off	off	off	off	off	off	off	off	off	off	off	off	off	off	off	off	off	off	off
Sweep Syringe/Needle I	on	off	on	off	off	off	off	off	off	off	off	off	off	off	off	off	off	off	off	off	off	off	off
Sweep Syringe/Needle II	on	off	on	off	off	off	off	off	off	off	off	off	off	off	off	off	off	off	off	off	off	off	off
Dry Purge	on	off	on	off	off	off	off	off	off	off	off	off	off	off	off	off	off	off	off	off	off	off	off
Desorb Ready	off	off	off	off	on	off	off	off	off	off	off	off	off	off	off	off	off	off	off	off	off	off	off
Desorb Preheat	off	off	off	off	on	off	off	off	off	off	off	off	off	off	off	off	off	off	off	off	off	off	off
Desorb	on	off	off	on	off	off	off	off	off	off	off	off	off	off	off	off	off	off	off	off	off	off	off
MeOH Rinse glass Fill	off	on	off	on	on	off	off	off	off	off	off	off	off	off	off	off	off	off	off	off	off	off	off
MeOH Rinse glass Transfer	off	off	on	off	on	on	on	off	off	off	off	off	off	off	off	off	off	off	off	off	off	off	off
MeOH Rinse Sweep	on	off	on	off	on	on	on	on	off	off	off	off	off	off	off	off	off	off	off	off	off	off	off
MeOH Rinse Drain	off	on	off	on	on	off	off	off	off	off	off	off	off	off	off	off	off	off	off	off	off	off	off
Bake Rinse Fill	off	on	off	on	on	off	off	off	off	off	off	off	off	off	off	off	off	off	off	off	off	off	off
Bake Rinse Transfer	off	off	on	off	on	on	on	off	off	off	off	off	off	off	off	off	off	off	off	off	off	off	off
Bake Rinse Sweep	on	off	on	off	on	on	on	on	off	off	off	off	off	off	off	off	off	off	off	off	off	off	off
Bake Rinse Drain	on	off	off	on	off	off	off	off	off	off	off	off	off	off	off	off	off	off	off	off	off	off	off
Bake	off	on	off	on	on	off	off	off	off	off	off	off	off	off	off	off	off	off	off	off	off	off	off



### 4.2.2 Soils

Mode	Valves												Mechanisms									
	Purge	Bake	Vent	Drain	Purge Select	Soil	Syringe	Liquid Transfer	Pressurize	Foam Transfer	Water Transfer	Water	IS #1	IS #2	IS #3	6-port Syringe Valve	6-port direction	MFC	Arm	Elevator	Mixer	
Standby	off	on	off	on	on	off	off	off	off	off	off	off	off	off	off	1	na	A	stby flow	home	up	off
Purge Ready	off	on	off	on	on	off	off	off	off	off	off	off	off	off	off	1	na	A	stby flow	home	up	off
Pre Sweep A	off	off	on	off	on	off	on	on	off	off	off	off	off	off	off	2	cw	A	50	home	up	off
Pre Sweep B	on	off	on	on	on	on	on	on	off	off	off	off	off	off	off	5	ccw	A	50	home	up	off
Move Vial	on	off	on	on	off	off	off	off	off	off	off	off	off	off	1	cw	A	stby flow	position	home	off	
Raise Vial	off	off	on	off	on	on	off	off	off	off	off	off	off	off	1	na	A	0	home	up	off	
Prepurge	on	off	on	off	off	off	off	off	off	off	off	off	off	off	1	na	A	pre purge flow	home	up	off	
DI Fill	off	off	on	off	on	on	off	off	off	off	off	off	off	off	4	ccw	A	0	home	up	off	
DI Dispense Waste	off	off	on	off	on	on	off	off	off	off	off	off	off	off	1	cw	A	0	home	up	off	
Std Dispense	off	off	on	off	on	on	off	off	off	off	off	off	on	on	1	na	A	0	home	up	off	
DI Transfer	off	off	on	off	on	on	off	off	off	off	off	off	off	off	5	ccw	A	0	home	up	off	
DI Sweep Waste	off	off	on	off	on	on	on	on	off	off	off	off	off	off	1	cw	A	0	home	up	off	
DI Sweep	on	off	on	off	on	on	on	on	off	off	off	off	off	off	5	ccw	A	di swp flow	home	up	off	
Sample Preheat	off	off	on	off	off	on	on	off	off	off	off	off	off	off	1	cw	A	0	home	up	off	
Purge	on	off	on	off	on	on	on	on	off	off	off	off	off	off	2	cw	A	purge flow	home	up	on	
Dry Purge	off	off	on	off	on	on	off	off	off	off	off	off	off	off	1	ccw	A	dry purge flow	home	up	on	
Lower Vial	off	off	on	off	on	on	off	off	off	off	off	off	off	off	1	na	A	n/a	home	home	off	
Move Vial	off	off	on	off	on	on	off	off	off	off	off	off	off	off	1	na	A	n/a	position	home	off	
Desorb Ready	off	off	off	off	on	on	off	off	off	off	off	off	off	off	1	na	A	0	home	up	off	
Desorb Preheat	off	off	off	off	on	on	off	off	off	off	off	off	off	off	1	na	A	0	home	up	off	
Desorb	on	off	off	on	off	on	on	off	off	off	off	off	off	off	1	na	B	drain flow	home	up	off	
MeOH Rinse Syringe Fill I	on	off	off	on	off	on	on	off	off	off	off	off	off	off	3	cw	B	drain flow	home	up	off	
MeOH Rinse Dispense I	on	off	off	on	off	on	on	off	off	off	off	off	off	off	2	ccw	B	drain flow	home	up	off	
MeOH Rinse Syringe Fill II	on	off	off	on	off	on	on	off	off	off	off	off	off	off	3	cw	B	drain flow	home	up	off	
MeOH Rinse Dispense II	on	off	off	on	off	on	on	off	off	off	off	off	off	off	5	ccw	B	drain flow	home	up	off	
Rinse Syringe Fill I	on	off	off	on	off	on	on	off	off	off	off	off	off	off	4	ccw	B	drain flow	home	up	off	
Rinse Syringe/Needle Dispense I	on	off	off	on	off	on	on	off	off	off	off	off	off	off	2	cw	B	drain flow	home	up	off	
Rinse Syringe Fill II	on	off	off	on	off	on	on	off	off	off	off	off	off	off	4	cw	B	drain flow	home	up	off	
Rinse Syringe/Needle Dispense II	on	off	off	on	off	on	on	off	off	off	off	off	off	off	5	cw	B	drain flow	home	up	off	
Sweep Syringe/Needle I	on	off	off	on	off	on	on	off	off	off	off	off	off	off	2	cw	B	drain flow	home	up	off	
Sweep Syringe/Needle II	on	off	off	on	off	on	on	off	off	off	off	off	off	off	5	cw	B	drain flow	home	up	off	
Bake	off	on	off	on	on	on	on	off	off	off	off	off	off	off	1	cw	A	bake flow	home	up	off	

### 4.2.3 Methanol Extraction

Mode	Valves													Mechanisms								
	Purge	Bake	Vent	Drain	Purge Select	Soil	Syringe	Liquid Transfer	Pressurize	Foam Transfer	Water Transfer	Water	IS #1	IS #2	IS #3	6-port Syringe Valve	6-port direction	MFC	Arm	Elevator	Mixer	
Standby	off	on	off	on	on	off	off	off	off	off	off	off	off	off	off	1	na	A	stby flow	home	up	off
Purge Ready	off	on	off	on	on	off	off	off	off	off	off	off	off	off	off	1	na	A	stby flow	home	up	off
Pre Sweep A	off	on	off	on	on	off	off	off	off	off	off	off	off	off	off	2	cw	A	stby flow	home	up	off
Pre Sweep B	off	on	off	on	on	off	off	off	off	off	off	off	off	off	off	5	ccw	A	stby flow	home	up	off
Move Vial	off	on	off	on	on	off	off	off	off	off	off	off	off	off	off	3	ccw	A	stby flow	position	home	off
Raise Vial	off	on	off	on	on	off	off	off	off	off	off	off	off	off	off	3	ccw	A	stby flow	home	up	off
Methanol Prime	off	on	off	on	on	off	off	off	off	off	off	off	off	off	off	3	ccw	A	0	home	up	off
Methanol Prime Dispense	off	on	off	on	on	off	off	off	off	off	off	off	off	off	off	1	cw	A	0	home	up	off
Methanol Fill	off	on	off	on	on	off	off	off	off	off	off	off	off	off	off	3	ccw	A	0	home	up	off
Methanol Dispense Waste	off	off	on	off	on	off	off	off	off	off	off	off	off	off	off	1	ccw	A	0	home	up	off
Matrix Spike Dispense	off	off	on	off	on	off	off	off	off	off	off	off	off	off	off	1	na	A	0	home	up	off
Methanol Dispense-Vial	off	on	off	on	on	off	off	off	off	off	off	off	off	off	off	5	ccw	A	150	home	up	off
Methanol Dispense Waste II	off	on	off	on	on	off	off	off	off	off	off	off	off	off	off	1	cw	A	150	home	up	off
Sweep Waste	off	on	off	on	on	off	off	off	off	off	off	off	off	off	off	1	na	A	150	home	up	off
Sweep Methanol	off	on	off	on	on	off	off	off	off	off	off	off	off	off	off	5	ccw	A	150	home	up	off
Mix Extract	off	on	off	on	on	off	off	off	off	off	off	off	off	off	off	1	cw	A	stby flow	home	mix	on
Settle time	off	on	off	on	on	off	off	off	off	off	off	off	off	off	off	1	na	A	stby flow	home	mix	off
Prime Extract Fill (Dil)	off	on	off	on	on	off	off	off	off	off	off	off	off	off	off	2	cw	A	50	home	up	off
Prime Extract Dispense (Dil)	off	on	off	on	on	off	off	off	off	off	off	off	off	off	off	1	ccw	A	50	home	up	off
Extract Fill (Dil)	off	on	off	on	on	off	off	off	off	off	off	off	off	off	off	2	cw	A	50	home	up	off
Extract Dispense-Waste1 (Dil)	off	on	off	on	on	off	off	off	off	off	off	off	off	off	off	1	ccw	A	0	home	up	off
Std Dispense (Dil)	off	off	on	off	on	off	off	off	off	off	off	off	off	off	off	1	na	A	0	home	up	off
Extract Dispense-Glassware (Dil)	off	off	on	off	on	off	off	off	off	off	off	off	off	off	off	5	ccw	A	0	home	up	off
Extract Dispense-Waste2 (Dil)	off	off	on	off	on	off	off	off	off	off	off	off	off	off	off	1	cw	A	0	home	up	off
Extract Sweep Waste (Dil)	off	off	on	off	on	off	off	off	off	off	off	off	off	off	off	1	na	A	0	home	up	off
DI Rinse Fill (Dil)	off	off	on	off	on	off	off	off	off	off	off	off	off	off	off	4	ccw	A	0	home	up	off
DI Rinse Dispense (Dil)	off	off	on	off	on	off	off	off	off	off	off	off	off	off	off	1	ccw	A	0	home	up	off
DI Fill (Dil)	off	off	on	off	on	off	off	off	off	off	off	off	off	off	off	4	cw	A	0	home	up	off
DI Dispense waste (Dil)	off	off	on	off	on	off	off	off	off	off	off	off	off	off	off	1	ccw	A	0	home	up	off
DI Transfer (Dil)	off	off	on	off	on	off	off	off	off	off	off	off	off	off	off	5	ccw	A	0	home	up	off
DI Sweep Waste (Dil)	off	off	on	off	on	off	off	off	off	off	off	off	off	off	off	1	cw	A	0	home	up	off

### Methanol Extraction (Continued)

Mode	Valves													Mechanisms										
	Purge	Bake	Vent	Drain	Purge Select	Soil	Syringe	Liquid Transfer	Pressurize	Foam Transfer	Water Transfer	Water	IS #1	IS #2	IS #3	6-port Syringe Valve	6-port direction	Valco 6-port	MFC	Arm	Elevator	Mixer		
Sweep DI (Dil)	on	off	on	off	on	off	on	off	on	off	on	off	on	off	on	off	on	off	on	off	on	off	on	off
Pre Purge (Dil)	on	off	on	off	on	off	on	off	on	off	on	off	on	off	on	off	on	off	on	off	on	off	on	off
Purge /Lower Vial	on	off	on	off	on	off	on	off	on	off	on	off	on	off	on	off	on	off	on	off	on	off	on	off
Move Vial	on	off	on	off	on	off	on	off	on	off	on	off	on	off	on	off	on	off	on	off	on	off	on	off
Raise Elevator	on	off	on	off	on	off	on	off	on	off	on	off	on	off	on	off	on	off	on	off	on	off	on	off
MeOH Rinse Syringe Fill I	on	off	on	off	on	off	on	off	on	off	on	off	on	off	on	off	on	off	on	off	on	off	on	off
MeOH Rinse Syringe/Needle Dispense I	on	off	on	off	on	off	on	off	on	off	on	off	on	off	on	off	on	off	on	off	on	off	on	off
MeOH Rinse Syringe Fill II	on	off	on	off	on	off	on	off	on	off	on	off	on	off	on	off	on	off	on	off	on	off	on	off
MeOH Rinse Syringe/Needle Dispense II	on	off	on	off	on	off	on	off	on	off	on	off	on	off	on	off	on	off	on	off	on	off	on	off
Rinse Syringe Fill I	on	off	on	off	on	off	on	off	on	off	on	off	on	off	on	off	on	off	on	off	on	off	on	off
Rinse Syringe/Needle Dispense I	on	off	on	off	on	off	on	off	on	off	on	off	on	off	on	off	on	off	on	off	on	off	on	off
Rinse Syringe Fill II	on	off	on	off	on	off	on	off	on	off	on	off	on	off	on	off	on	off	on	off	on	off	on	off
Rinse Syringe/Needle Dispense II	on	off	on	off	on	off	on	off	on	off	on	off	on	off	on	off	on	off	on	off	on	off	on	off
Sweep Syringe/Needle I	on	off	on	off	on	off	on	off	on	off	on	off	on	off	on	off	on	off	on	off	on	off	on	off
Sweep Syringe/Needle II	on	off	on	off	on	off	on	off	on	off	on	off	on	off	on	off	on	off	on	off	on	off	on	off
Dry Purge	off	off	on	off	on	off	on	off	on	off	on	off	on	off	on	off	on	off	on	off	on	off	on	off
Desorb Ready	off	off	on	off	on	off	on	off	on	off	on	off	on	off	on	off	on	off	on	off	on	off	on	off
Desorb Preheat	off	off	on	off	on	off	on	off	on	off	on	off	on	off	on	off	on	off	on	off	on	off	on	off
Desorb	off	off	on	off	on	off	on	off	on	off	on	off	on	off	on	off	on	off	on	off	on	off	on	off
MeOH Rinse glass Fill	off	off	on	off	on	off	on	off	on	off	on	off	on	off	on	off	on	off	on	off	on	off	on	off
MeOH Rinse glass Transfer	off	off	on	off	on	off	on	off	on	off	on	off	on	off	on	off	on	off	on	off	on	off	on	off
MeOH Rinse Sweep	off	off	on	off	on	off	on	off	on	off	on	off	on	off	on	off	on	off	on	off	on	off	on	off
MeOH Rinse Drain	off	off	on	off	on	off	on	off	on	off	on	off	on	off	on	off	on	off	on	off	on	off	on	off
Bake Rinse Fill	off	off	on	off	on	off	on	off	on	off	on	off	on	off	on	off	on	off	on	off	on	off	on	off
Bake Rinse Transfer	off	off	on	off	on	off	on	off	on	off	on	off	on	off	on	off	on	off	on	off	on	off	on	off
Bake Rinse Sweep	on	off	on	off	on	off	on	off	on	off	on	off	on	off	on	off	on	off	on	off	on	off	on	off
Bake Rinse Drain	on	off	on	off	on	off	on	off	on	off	on	off	on	off	on	off	on	off	on	off	on	off	on	off
Bake	off	off	on	off	on	off	on	off	on	off	on	off	on	off	on	off	on	off	on	off	on	off	on	off

## 4.3 Optimization/Method Development



### NOTE

Also refer to 4.5 "Analytical Trap Recommended Operating Conditions".

Temperature settings are common to all modes of operations. Therefore, when developing a method, determine temperature settings first.



### NOTE

The system does not actively attempt to control temperatures below 35 °C (ambient) unless the laboratory temperature requires it.

The temperature range for the Atomx XYZ sample transfer line and 6-port valve oven is 35 - 250 °C. For environmental samples, the most common temperature for the sample transfer line and 6-port valve oven is 150 °C. Flavor and fragrance samples are usually run at higher line and valve temperatures.

The temperature range for the Atomx XYZ sample mount is 35-100 °C. The typical sample mount temperature is 90 °C. In some cases the sample mount will be set to ambient temperature to allow for condensation of water prior to entering the sample pathway.

### Standby Mode

The Standby Mode temperatures are for the analytical trap and the MCS. The Atomx XYZ will not automatically advance from standby to purge ready, if the trap and MCS temperatures are above the set standby temperatures. The standby temperature range is 40-350 °C for the trap and 40-200 °C for the Moisture Control System (MCS). However, the typical setting is between 30-45 °C for the trap to prevent a sample from purging on to a hot trap, which may result in incomplete trapping. The typical temperature setting for the MCS is 40-45 °C when used for water removal. If the MCS is not being used as a condensate trap, it is good practice to use the same temperature as the sample transfer line and 6-port valve oven temperature. The MCS works most efficiently with lower temperatures. However, you may use higher temperatures to reduce the possibility of removing highly polar compounds such as ethanol.

The standby flow can be set on the Atomx XYZ to allow the system to have continual gas flow while the unit is sitting idle. This flow keeps the Atomx XYZ under positive pressure, which prevents lab air contamination to the system, and prevents oxygen from being introduced to the trap and tubing, which can result in deterioration. Typical standby flows are set between 0-10 mL/min.

### Purge Ready Mode

Purge Ready Mode indicates the trap and MCS have cooled below their respective set standby temperatures and all other temperature set-points have been reached. Once the unit has reached this mode, the user can initiate the run.



## Pre-Purge Mode



### NOTE

Pre-Purge Mode is not used unless the sample heater is installed.

Pre-purge allows the sparger to be swept with purge gas to remove oxygen in the headspace prior to heating the sample. The pre-purge flow is directed through the trap so any VOCs removed during this mode are retained. Usually, pre-purge time allows the volume of the sparger to be swept three times.



### NOTE

Pre-purge Flow should not exceed Purge Flow.

The volumes of a 5 mL and 25 mL sparger are 11 mL and 34 mL, respectively. Use the calculation below to find the pre-purge time:

$$\frac{3 \times \text{Actual Volume of Sparger (mL)}}{\text{Pre-purge Flow (mL/min)}} = \text{Pre-Purge Time}$$

## Sample Temperature and Pre-Heat Mode



### NOTE

Sample temperature and preheat time are not used unless the sample heater is installed. To enable the sample heater, select the check box on the Method Screens Purge Tab.

The sample temperature range is 35-80 °C. For environmental samples, the typical range is 40-60 °C. Flavor and fragrance analysis may have much higher temperatures. Preheat time is used to allow the heaters to reach their temperature set-points before purge. This ensures that all samples are purged under the desired conditions.

For every 10 degree increase in sample temperature, the amount of water removed is doubled. The 80 °C setpoint for the sample heater is typically used to clean the system in the event of high-level contamination of the system. Contact a Teledyne Tekmar Customer Support Representative using the information in Section P.2 "Teledyne Tekmar Customer Support Center" prior to attempting the high temperature cleaning process.

### 4.3.1 Purge Mode

During Purge Mode, gas is passed through the sample. This causes volatiles to be removed for analysis. Purge has two controlling factors: the duration of the purge and the flow rate of the gas. This determines the total amount of gas passed through the sample, which is referred to as the purge volume. In most applications, the purge volume should never exceed 600 mL.

The recommended flow rate is 40 mL/min for 11 minutes or 440 mL purge volume. There are some applications where slower flow rates are helpful. For example, if you are looking for very light compounds, a slower flow rate will improve trapping efficiency.

The purge volume for most applications should be between 400-500 mL. To deliver the correct purge volume, you must determine the correct purge time.

The recommended setting for the trap purge temperature is 0 °C. A higher temperature decreases water adsorption, but can also significantly decrease trapping efficiency for the target compounds.

The typical temperature setting for the MCS during purge is 20 °C when used for water removal. If the MCS is not being used as a condensate trap, it is good practice to use the same temperature as the sample transfer line and 6-port valve oven temperature. The MCS works most efficiently with lower temperatures. However, you may use higher temperatures to reduce the possibility of removing highly polar compounds such as ethanol.

### 4.3.2 Dry Purge Mode

Dry Purge Mode is used to remove water from the trap and can be used when a #1, #7, #8, #9, Vocarb® 3000, or Vocarb® 4000 trap is installed (because they are hydrophobic). Dry purge should also be used any time the Moisture Control System (MCS) is not being used as a condensate trap.

Dry purge causes “dry” purge gas to pass through the trap, pushing water off the trap and out the vent. In this mode the trap is already loaded with the compounds of interest, so dry purging for too long, too fast, or at too high of a temperature may result in a lower response due to breakthrough. Usually, the duration of dry purge is 0.5 to 6 minutes. A 0.5 to 2 minute dry purge time should be used to achieve the highest efficiency. The dry purge flow range is 5-500 mL/min, however, it is not recommended to exceed 300 mL/min. The recommended trap temperature is between 0-45 °C. A higher temperature will improve water removal, but will reduce the volume of purge gas that can be passed through the trap before significant loss of target compounds occurs.

### 4.3.3 Desorb Ready Mode

Desorb Ready Mode indicates that the trap has been loaded with VOCs and the Atomx XYZ is ready to desorb. If the GC is not ready, the Atomx XYZ will wait for the GC during this mode. While the Atomx XYZ is in this mode, there is no flow or heat through the trap; the Atomx XYZ is in a static state.

### 4.3.4 Desorb Pre-Heat Mode

Desorb Preheat Mode is used to heat up the trap, without flow, to release the analytes from the sorbents. This is done to get a very tight “slug” or band of analytes to the GC. The goal is to introduce the “slug” in as little time as possible, resembling a direct injection. A typical desorb preheat temperature is 5 °C below the desorb temperature. The Atomx XYZ will hold in this mode for 0.33 min to ensure full heat transfer to the center of the trap.

### 4.3.5 Desorb Mode

In desorb, the 6-port valve rotates to backflush analytes from the analytical trap to the GC. You must select time and temperature values for desorb. The temperature should be selected on the basis of what type of trap is installed. The desorb temperature range is 40-350 °C. Typical values range between 180-260 °C. The duration of desorb must be selected with column Interior Diameter (ID) and flow rate in mind. You must consider flow rate because the trap is desorbed with carrier gas flow. Allow enough time to fully desorb the compound with the highest boiling point. Time values range from 0.5 to 8 minutes, depending on flow rates. The desorb flow rate should be set to 200-300 mL/min. This flow rate is regulated by the MFC to allow the sample to be drained from the sparger prior to stepping to Bake. The desorb flow rate should be set high enough to ensure that the sample is completely drained during the mode. If the sample is not fully removed, it will continue to drain during Bake Mode.

### 4.3.6 Bake Mode

Bake Mode is used to regenerate the trap and MCS for the next run. This removes any volatiles remaining on the trap and any water in the system. During bake, flow is passed through the sample pathway with temperatures for the analytical trap and the MCS elevated to help clean the system. Trap bake temperatures should be selected based upon the type of trap being used in the Atomx XYZ. Typical trap bake temperatures can range from 270-300 °C. If the MCS has been used as a condensate trap, the temperature will typically be set to between 150-200 °C for bake. If the MCS is not being used to remove water, it will be held steady with the sample transfer line and 6-port valve oven temperatures. Flow rates for bake can range between 5-500 mL/min. If cycle time is being minimized, a flow rate of 300-400 mL/min is recommended for 2-4 minutes. Too short of a bake time can result in higher carryover.

## 4.4 Method Parameters

### 4.4.1 Water

Water Methods	Max	Min	Default	Unit
Valve Oven Temperature	250	20	140	°C
Transfer Line	250	20	140	°C
Sample Mount	100	20	90	°C
Water Heater	90	20	90	°C
Soil Valve	125	20	100	°C
Sample Cup	60	20	20	°C
Standby Flow	500	0	10	ml/min
Purge Ready Temp	350	20	40	°C
MCS Ready Temp	250	20	45	°C
Pre Sweep Time	299.99	0	0.5	min
Prime Sample Fill	25	0	3	ml
Sample Volume	25	0	5	ml
Sweep Sample	299.99	0	0.25	min
Sample Equilibration Time	299.99	0	0	min
Sweep Sample Flow	500	0	100	ml/min
Sparge Vessel Heater	On	Off	Off	N/A
Purge Vessel Temp	100	20	40	°C
Prepurge Time	299.99	0	0	min
Prepurge Flow	500	0	0	ml/min
Purge Time	299.99	0	11	min
Purge Flow	500	0	40	ml/min
Purge Temp	350	20	20	°C
MCS Purge Temp	200	20	20	°C
Dry Purge Time	299.99	0	0.5	min
Dry Purge Flow	500	0	100	ml/min
Dry Purge Temp	350	20	20	°C
Methanol Needle Rinse	On	Off	Off	N/A
Methanol Needle Rinse	On	Off	Off	N/A
Methanol Needle Rinse Volume	25	0	3	ml
Water Needle Rinse Volume	25	0	7	ml
Sweep Needle Time	299.99	0	0.25	min
GC Start Signal	None, Start, End or Both		Start of Desorb	N/A
Desorb Preheat	350	20	245	°C
Desorb Time	299.99	0	2	min
Drain Flow	500	0	300	ml/min
Desorb Temp	350	20	250	°C
Number of Bake Rinses	5	0	1	N/A
Bake Rinse Volume	25	0	7	ml
Bake Rinse Sweep Time	299.99	0	0.25	min
Bake Rinse Sweep Flow	500	0	100	ml/min
Bake Rinse Drain Time	299.99	0	0.4	min
Methanol Glass Rinse	On	Off	Off	N/A
Number of Methanol Glass Rinses	5	0	0	N/A
Methanol Glass Rinse Volume	25	0	3	ml
Bake Time	299.99	0	2	min
Bake Flow	500	0	200	ml/min
Bake Temp	350	20	280	°C
MCS Bake Temp	200	20	180	°C



#### 4.4.2 Soil

Soil Methods	Max	Min	Default	Unit
Valve Oven Temperature	250	20	140	°C
Transfer Line	250	20	140	°C
Sample Mount	100	20	90	°C
Water Heater	90	20	90	°C
Soil Valve	125	20	100	°C
Sample Cup	80	20	40	°C
Standby Flow	500	0	10	ml/min
Purge Ready Temp	350	20	40	°C
MCS Ready Temp	200	20	45	°C
Pre Sweep	299.99	0	0.25	min
Water Volume	25	0	10	ml
Sweep Water Time	299.99	0	0.25	min
Sweep Water Flow	500	0	100	ml/min
Sparge Vessel Heater	On	Off	Off	N/A
Prepurge Temp	100	20	20	°C
Prepurge Time	299.99	0	0	min
Prepurge Flow	500	0	0	ml/min
Sample Preheat Mix	Fast	Slow	Medium	N/A
Preheat Mix Time	299.99	0	2	N/A
Purge Time	299.99	0	11	min
Purge Flow	500	0	40	ml/min
Purge Temp	350	20	20	°C
MCS Purge Temp	200	20	20	°C
Dry Purge Time	299.99	0	2	min
Dry Purge Flow	500	0	100	ml/min
Dry Purge Temp	350	20	20	°C
Methanol Needle rinse	On	Off	Off	N/A
Methanol Needle Rinse Volume	25	0	3	ml
Water Needle Rinse Volume	25	0	7	ml
Sweep Needle Time	299.99	0	0.25	min
GC Start Signal	None, Start, End or Both		Start of Desorb	N/A
Desorb Time	299.99	0	2	min
Drain Flow	500	0	300	ml/min
Desorb Temp	350	20	250	°C
Bake Time	299.99	0	2	min
Bake Flow	500	0	200	ml/min
Bake Temp	350	20	280	°C
MCS Bake Temp	200	20	180	°C

### 4.4.3 Methanol Extraction

Methanol Methods	Max	Min	Default	Unit
Valve Oven Temperature	250	20	140	°C
Transfer Line	250	20	140	°C
Sample Mount	100	20	90	°C
Water Heater	90	20	90	°C
Soil Valve	125	20	100	°C
Sample Cup	60	20	20	°C
Standby Flow	500	0	10	ml/min
Purge Ready Temp	350	20	40	°C
MCS Ready Temp	200	20	45	°C
Pre Sweep	299.99	0	0.25	min
MeOH Volume	25	0	10	ml
Sweep Methanol	299.99	0	0.5	min
Sweep Methanol Flow	500	0	100	ml/min
Sparge Vessel Heater	On	Off	Off	N/A
Prepurge Temp	100	20	20	°C
Prepurge Time	299.99	0	0	min
Prepurge Flow	500	0	0	ml/min
Sample Mix Speed	Fast	Slow	Medium	N/A
Sample Mix Time	299.99	0	2	N/A
Sample Mix Settle time	299.99	0	2	N/A
Sweep Sample time	299.99	0	0.25	min
Sweep Sample Flow	500	0	100	ml/min
Purge Time	299.99	0	11	min
Purge Flow	500	0	40	ml/min
Purge Temp	350	20	20	°C
MCS Purge Temp	200	20	20	°C
Methanol Needle Rinse	On	Off	on	N/A
Methanol Needle Rinse Volume	25	0	2	ml
Water Needle Rinse Volume	25	0	7	ml
Sweep Needle Time	299.99	0	0.25	min
GC Start Signal	None, Start, End or Both		Start of Desorb	N/A
Dry Purge Time	299.99	0	1	min
Dry Purge Flow	500	0	100	ml/min
Dry Purge Temp	350	20	20	°C
Desorb Time	299.99	0	2	min
Drain Flow	500	0	300	ml/min
Desorb Temp	350	20	250	°C
Number of Bake Rinses	5	0	1	N/A
Bake Rinse Volume	25	0	7	ml
Bake Rinse Sweep Time	299.99	0	0.5	min
Bake Rinse Sweep Flow	500	0	100	ml/min
Methanol Glass Rinse	On	Off	Off	N/A
Number of Methanol Glass Rinses	5	0	0	N/A
Methanol Glass Rinse Volume	25	0	3	ml
Bake Time	299.99	0	2	min
Bake Flow	500	0	200	ml/min
Bake Temp	350	20	280	°C
MCS Bake Temp	200	20	180	°C

## 4.5 Analytical Trap Recommended Operating Conditions

**Table 4-2 Analytical Trap Recommended Operating Conditions**

Description	Part #	Standby Temp	Dry Purge Flow	Dry Purge Time	Dry Purge Temp	Desorb Preheat Temp	Desorb Temp	Bake Temp
(#1) Tenax®	12-0083-403	35	100	2	20	220	225	230
(#1A) Tenax® <sup>a</sup>	12-0083-503	35	100	2	20	220	225	230
(#2) Tenax®/Silica Gel	12-0084-403	35	0	0	N/A	220	225	230
(#3) Tenax®/Silica Gel/Charcoal	14-0124-403	35	0	0	N/A	220	225	230
(#4) Tenax®/Charcoal	14-1457-403	35	100	2	20	220	225	230
(#5) OV®-1/Tenax®/Silica Gel/Charcoal	14-2366-403	35	0	0	N/A	220	225	230
(#6) OV®-1/Tenax®/Silica Gel	14-1755-403	35	0	0	N/A	220	225	230
(#7) OV®-1/Tenax®	14-3347-403	35	100	2	20	220	225	230
(#8) Carbopack™ B/Carbosieve® S-III	14-3928-403	35	100	2	20	245	250	260
(#9) Trap (Proprietary)	14-9908-403	35	100	2	20	245	250	260
(#10) Tenax®/Silica Gel/Carbosieve® S-III	14-9909-403	35	0	0	N/A	220	225	230
(#11) VPH Trap (Proprietary)	15-0884-403	35	100	2	20	245	250	260
(K) Vocarb® 3000	14-5864-403	35	100	2	20	245	250	260
Vocarb® 4000	14-5865-403	35	100	2	20	245	250	260
BTEX™	14-5866-403	35	100	2	20	245	250	260
BTEX™ + MTBE	14-9333-403	35	100	2	20	245	250	260

a. Uses a different mesh size.



# Atomx XYZ User Manual

## Chapter 5: Maintenance and Troubleshooting



### NOTE

Caution and Warning Symbols are defined in Section P.5 "Atomx XYZ Safety Symbols Defined" and Section P.6 "Atomx XYZ Safety Labels".

Les symboles d'Alerte et de Danger sont définis dans la section P.5 "Symboles Sécurité Atomx XYZ" la section P.6 "Label Sécurité Atomx XYZ" (Section P.5 "Atomx XYZ Safety Symbols Defined" and Section P.6 "Atomx XYZ Safety Labels").



### DANGER

**WARNING: Remove the power cable before performing maintenance and/or servicing the instrument.**

**DANGER - Débrancher le câble d'alimentation avant toutes interventions de maintenance et/ou d'entretien sur l'instrument.**

### 5.1 Replacing Parts

For replacement part numbers contact Teledyne Tekmar Customer Support using the information in Section 5.26 "Technical Assistance".



### WARNING

**Only use replacement parts supplied or approved by Teledyne Tekmar when performing maintenance on the Atomx XYZ. Use of unapproved parts could result in damage to the instrument, as well as personal injury.**



### DANGER

**Only replace the Atomx XYZ mains supply AC power cable with a UL listed cable of the same current and voltage rating. Only replace fuses with those of the same type and rating. Refer to Section 5.19 "Power Entry Module (PEM) Fuse Replacement".**

## 5.2 Preventative Maintenance Checks

A carefully designed and faithfully executed Preventative Maintenance Program is the best method for maintaining the Atomx XYZ. Adherence to scheduled maintenance in the areas of cleaning, checking of parts, and lubrication will help continue the performance standards of the unit and decrease the possibility of down time.

The Preventative Maintenance Schedule below lists procedures that can be performed without the assistance of a Teledyne Tekmar Support Representative. The more familiar you become with these procedures, the less time it will take to complete them.



### NOTE

The Atomx XYZ autosampler arm is self-lubricating and does not require any preventative maintenance. Lubricating the arm in any way will degrade performance.

### 5.2.1 Daily Maintenance Checks

Table 5-1 Daily Maintenance Checklist	
Verify Gas Supply	Verify the gas source is supplying an input pressure of 65 - 100 psi (4.48 bar - 6.89 bar) to the Atomx XYZ. If using a gas cylinder, verify the cylinder is at 500+psi (34.5 bar). If not, replace the cylinder.
Inspect Waste	Verify that the waste container has sufficient volume to contain the waste generated. Empty if necessary.
Replace DI Water Supply	Replace the DI water supply with fresh DI water. Make sure the DI water supply is sufficient for sample analysis (1L minimum).
Perform Leak Check	Run a leak check to ensure that the unit is leak tight. Refer to Section 5.8 "System Leak Check".
Clean Vial Rack Holes	Check the autosampler vial rack holes for foreign particles. Clean if necessary.
Verify Internal Standard (IS) Supply	Make sure the internal standard supply is sufficient for sample analysis.

### 5.2.2 Weekly Maintenance Checks

Table 5-2 Weekly Maintenance Checklist	
Perform Daily Checks	
Verify Purge Pressure Stability	Scan through the Sample History Log (Tools Screen>View History Log>Sample History Tab) to verify that the purge pressures are staying consistent throughout the daily runs.
Check/Set Internal Standard Pressure	Check the internal standard pressure in the Atomx XYZ software. Refer to Section 5.10 "Verifying/Setting Internal Standard Vessel Pressure".
Inspect Sample Needle	Inspect the sample needle for particles or calcification. Replace if necessary. Refer to Section 5.11 "Sample Needle Replacement".

### 5.2.3 Monthly Maintenance Checks

Table 5-3 Monthly Maintenance Checklist	
Perform Daily and Weekly Checks	
Inspect Sparger Glassware	Inspect for damage and/or discoloration that could restrict flow or cause contamination. Refer to Section 5.9 "Glassware Good Practices Cleaning Procedures". Replace as necessary.
Inspect Drain Tubing	Inspect the drain tubing for clogging. Replace drain line if necessary.

### 5.2.4 Quarterly Maintenance Checks

Table 5-4 Quarterly Maintenance Checklist	
Perform Daily, Weekly and Monthly Checks	
Lubricate the Atomx XYZ Elevator	Refer to Section 5.15 "Elevator Lubrication".



#### NOTE

The Installation Kit Box includes most of the items needed for routine maintenance of the Atomx XYZ.

### 5.3 Preventative Maintenance Chart

**Table 5-5 Preventative Maintenance Chart**

Rate	Action	Check When Completed						
<b>Daily</b>	Verify Sample Purge Gas: 500+ psi (34.5+ bar) at tank							
	Verify Stage 2 Pressure: 65 - 100 psi (4.48 bar - 6.89 bar)							
	Inspect Waste							
	Replace DI Water Supply							
	Perform Leak Check							
	Clean Vial Holes							
	Verify Internal Standard (IS) Supply							
	Initials & Date							
<b>Weekly</b>	Daily Maintenance Items							
	Verify Purge Pressure Stability							
	Verify /Set Internal Standard Pressure							
	Inspect Sample Needle							
	Initials & Date							
<b>Monthly</b>	Daily & Weekly Maintenance Items							
	Inspect Sparger Glassware							
	Inspect Drain Tubing							
	Initials & Date							
<b>Quarterly</b>	Daily, Weekly and Monthly Maintenance Items							
	Lubricate the Atomx XYZ Elevator							
	Initials & Date							



## 5.4 GC In/Out (I/O) Cable and GC Type Reference



### NOTE

If Table 5-6 "GC I/O Cable and GC System Reference" does not contain your GC System, contact Teledyne Tekmar Customer Support using the contact information in Section 5.26 "Technical Assistance".

**Table 5-6 GC I/O Cable and GC System Reference**

Part Number	GC System	GC Type
14-2371-000	Varian Vista Series with 401 or 402 Data System	Standard
14-2372-000	Shimadzu 9A	User
14-2377-100	Hewlett-Packard (HP) 5700 Series (excluding 5710/30/90)	Standard
14-3054-000	HP 5983/93/95 with SIDS Data System	Standard
14-3168-000	HP 5710/30/90 or 5790 with MSD and Chemstation/ Quicksilver software	Standard
14-3170-000	HP 5840A/80A	User
14-3171-000	HP 5890	User
14-3172-000	Perkin-Elmer Sigma Series	User
14-3176-000	Tracor 540/800 Series MS	Standard
14-3312-000	HP5890 with RTE and HP-1000 GC/MS software with 5970MSD or 5988 MS	Standard
14-3315-000	General Use. Any GC/MS that has electronic READY and REMOTE START signals	See Instructions
14-3316-100	Varian 3700	Standard
14-3319-000	HP 5995 GC/MS with Chemstation/Quicksilver software	Standard
14-3320-000	General HP GC/MS with RTE Software	User
14-3335-000	Perkin-Elmer 8000 Series or 9000 Autosystem	Standard
14-3569-000	Varian 3300, 3400, and 3600 Series without Serial I/O	Standard
14-4009-100	Finnagin 5100	Standard
14-4188-074	HP 5890 with 5970 MSD or 5988 MS with Unix or Pascal based Chemstation	Standard
14-4610-074	Shimadzu 14A, 15A, and 17A	Standard
14-4652-074	HP 5890 with 5971 MSD (MS/DOS) or HP Engine GC	User
14-4655-074	2 units to a Tracor 540/800 Series MS	Standard
14-4830-074	2 units to a HP 5890	Standard
14-4938-074	Carlo Erba Vega/Mega or 8000	Standard
14-5044-074	1 or 2 units to a Varian 3400/3600/Data System/Integrator (with Serial I/O)	Standard
14-5397-074	2 units to a Perkin-Elmer 8000 Series or 9000 Autosystem	Standard
14-6689-074	HP 6890	User

## 5.5 Instrument Access Panels

The Atomx XYZ has the following access panels:

- Sparger Panel Door
- Analytical Trap Door
- Right-Side Access Panel
- Valve Oven Cover
- Autosampler Access Panel

Access panels are secured to the instrument chassis with phillips-head screws and locater pins. Remove the Phillips screws from the side panel that is being removed.



**The Atomx XYZ is designed to keep liquid spills from coming in contact with electronics inside the unit. The Atomx XYZ access panels must be installed prior to turning the instrument ON.**

Figure 5-1 Front of the Atomx XYZ

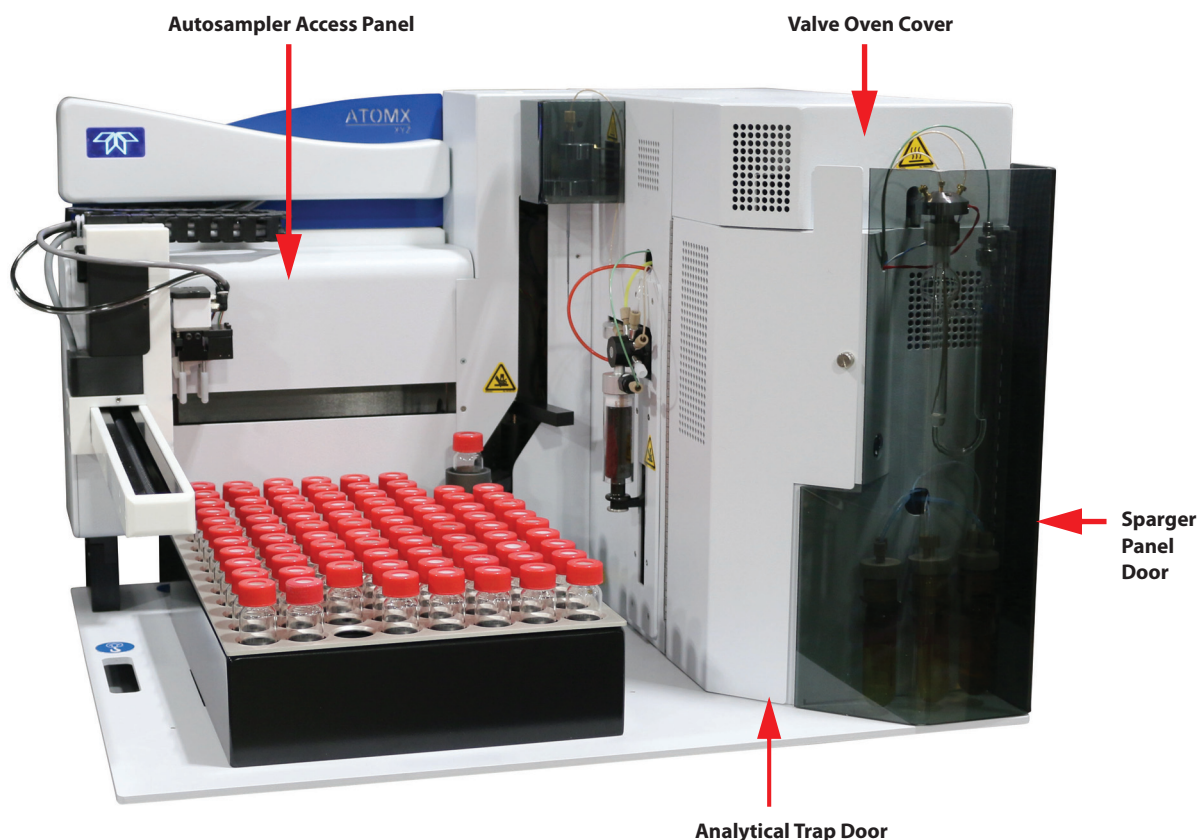
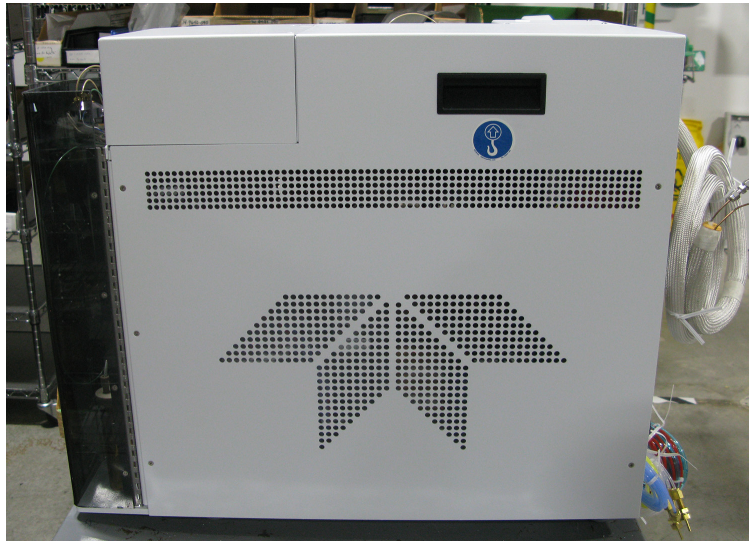

Figure 5-2 Right Side of Atomx XYZ



↑  
Right Access Panel

Figure 5-3 Analytical Trap Compartment and Sparger Panel Open

Moisture Control System (MCS)

Resistance Temperature Detector (RTD)

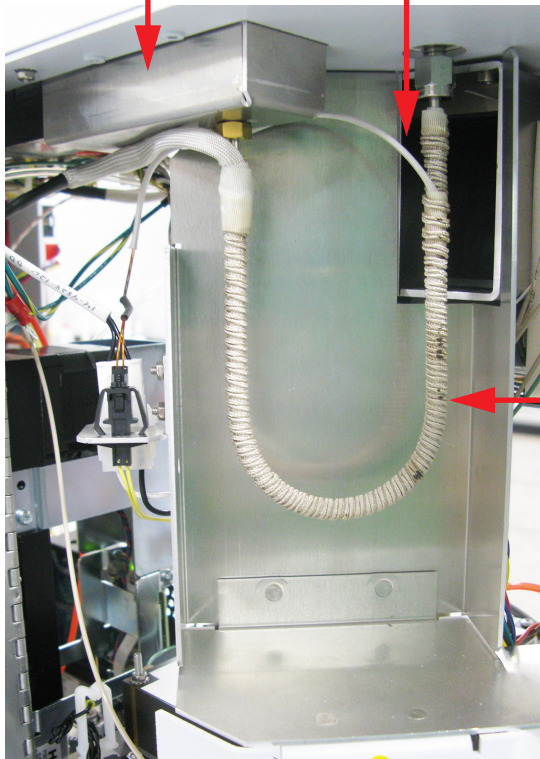

Analytical Trap Compartment Open

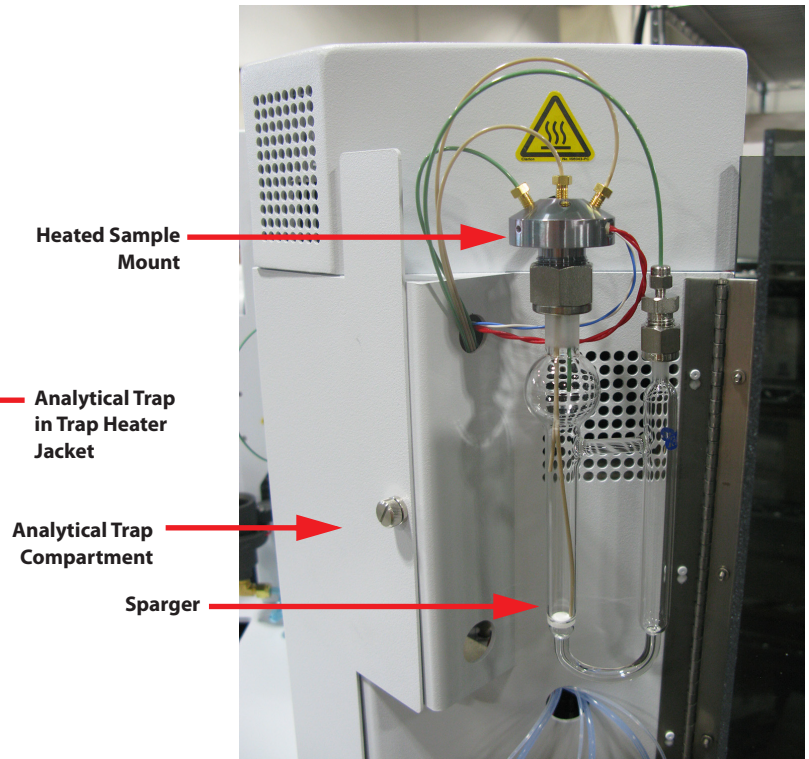

Heated Sample Mount

Analytical Trap in Trap Heater Jacket

Analytical Trap Compartment

Sparger

Sparger Panel Open



## 5.6 Plumbing Overview



### NOTE

Also refer to Section A.3 "Atomx XYZ Plumbing Diagram".

Figure 5-4 Plumbing Components

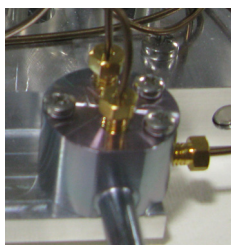

4-Way Tee

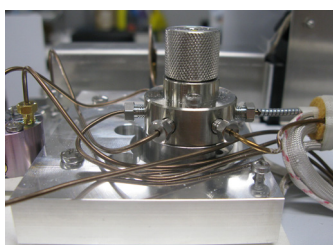

6-Port Valve

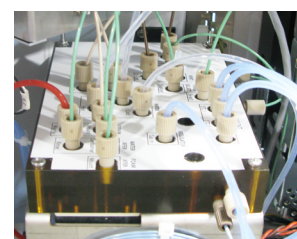

Valve Manifold



Sample Mount and Sparger



Analytical Trap

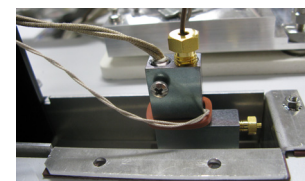

Moisture Control System

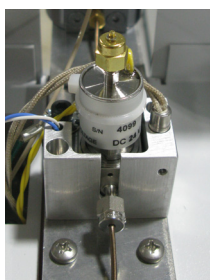

Soil Valve



Water Heater/Reservoir



IS Pressure Regulator



Syringe

Figure 5-5 Plumbing Components

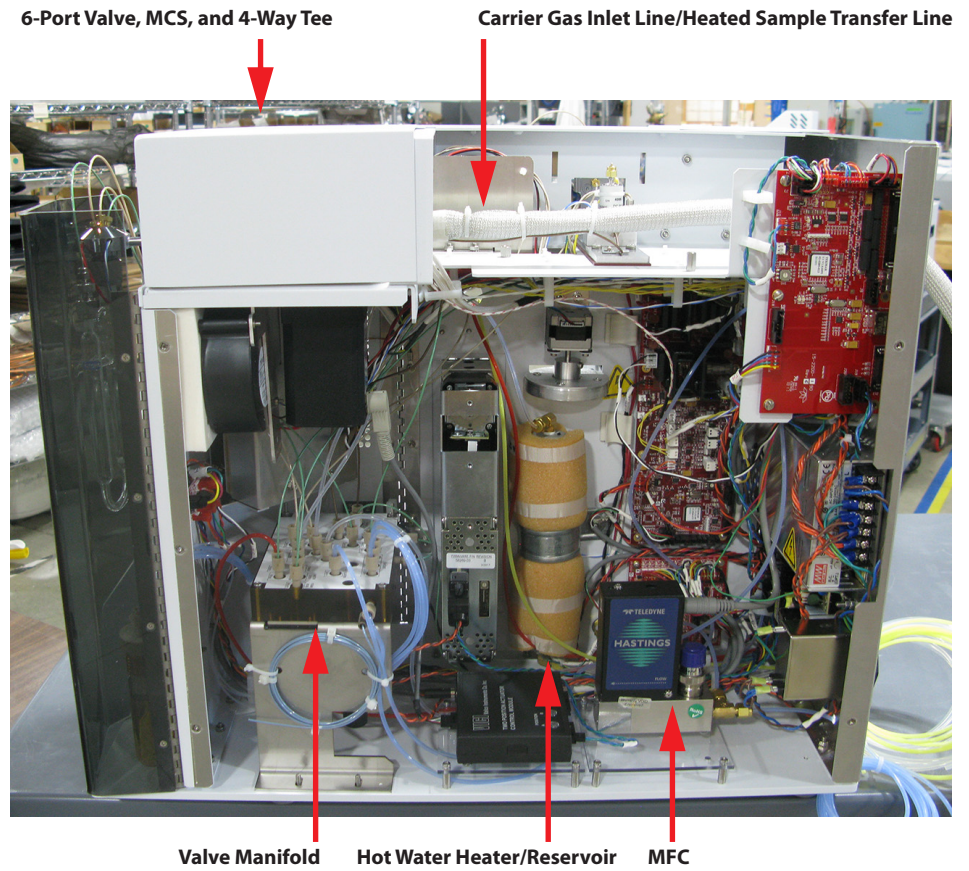

## 5.7 Electrical Overview



### NOTE

Also refer to Section A.1 "Atomx XYZ Concentrator Electrical Schematic" and Section A.2 "Atomx XYZ Autosampler Electrical Schematic".

Figure 5-6 Electrical Components

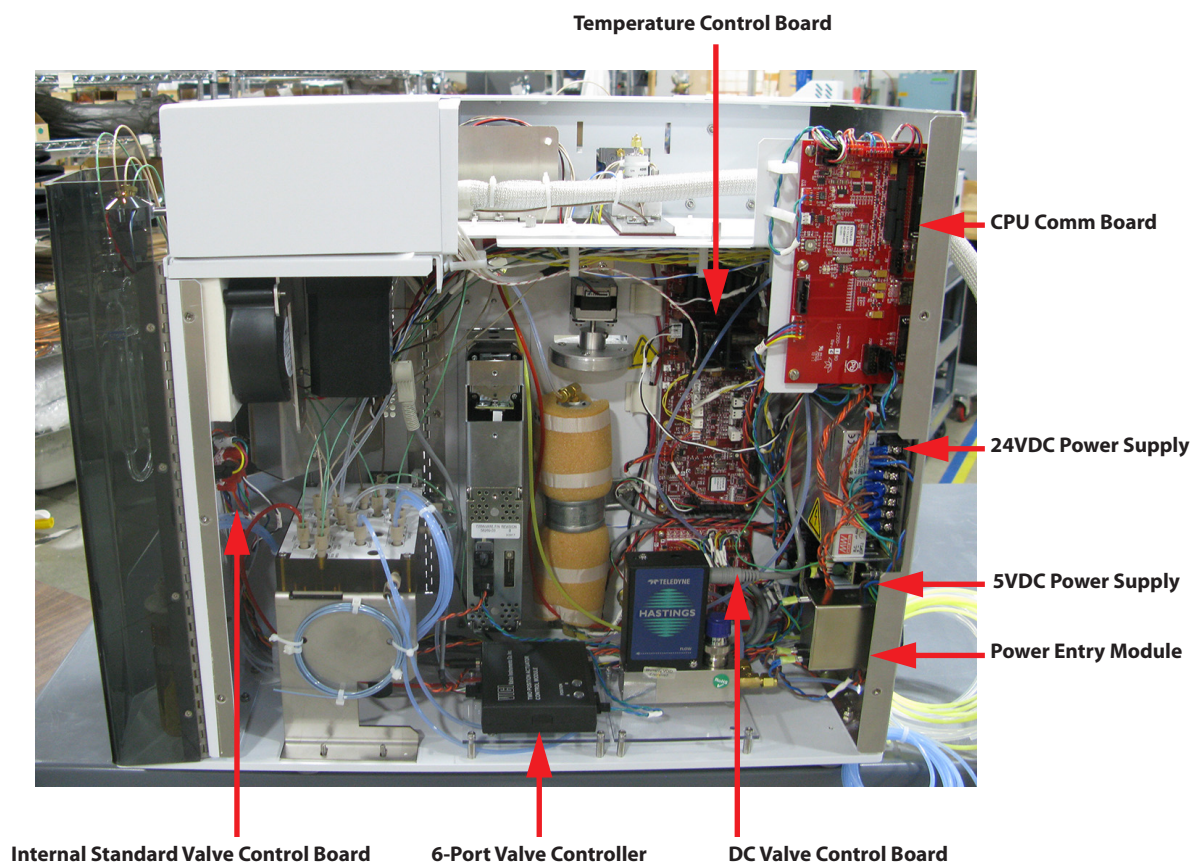

### 5.7.1 Printed Circuit Boards

The Atomx XYZ has nine Printed Circuit Boards (PCB):

- CPU Communication Board
- Multi-Channel Temperature Control Board
- DC Valve Control Board
- Internal Standard Valve Control Board
- Banner Display Board
- XYZ Interface Board
- XYZ Control Board
- XYZ Input/Output Board
- Elevator Drive Board



Locations of the boards are shown in Figure 5-7 and Figure 5-8. Diagrams of the boards are affixed to the interior of the instrument, as well as shown in relevant maintenance procedures.

Figure 5-7 Printed Circuit Board Locations - Atomx XYZ Concentrator

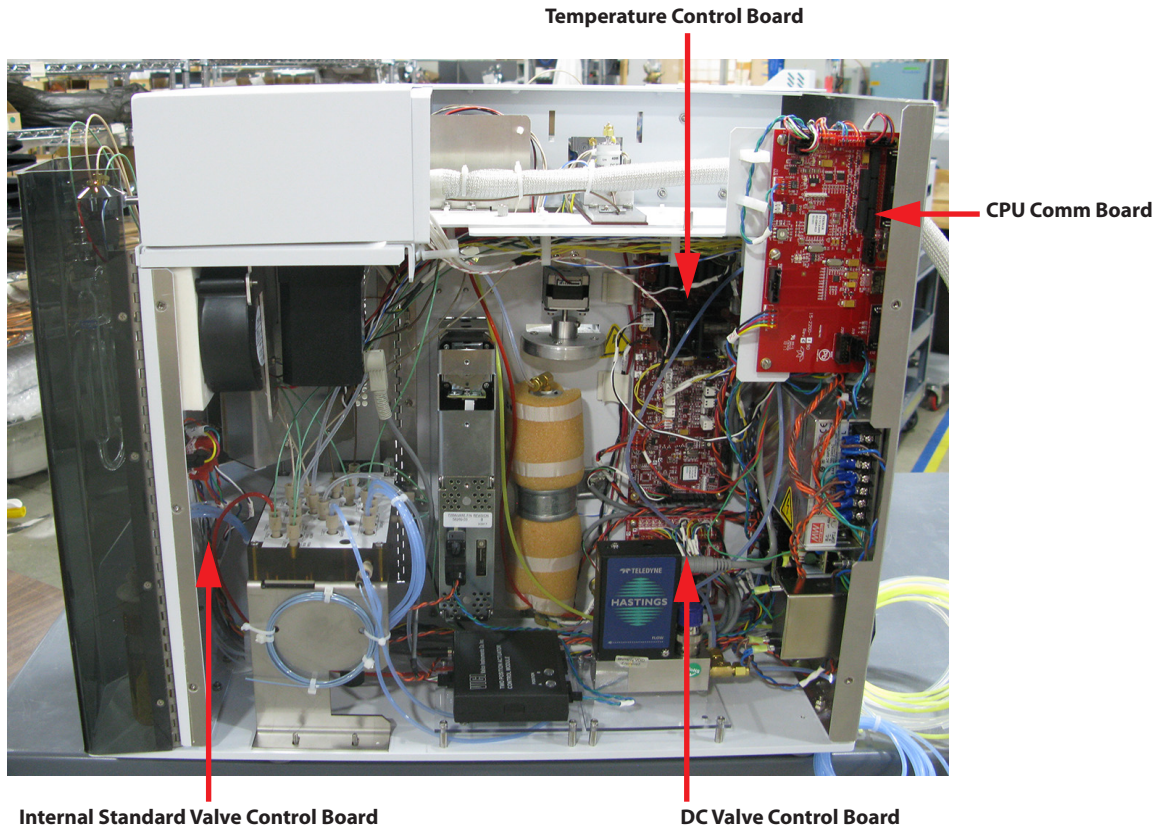
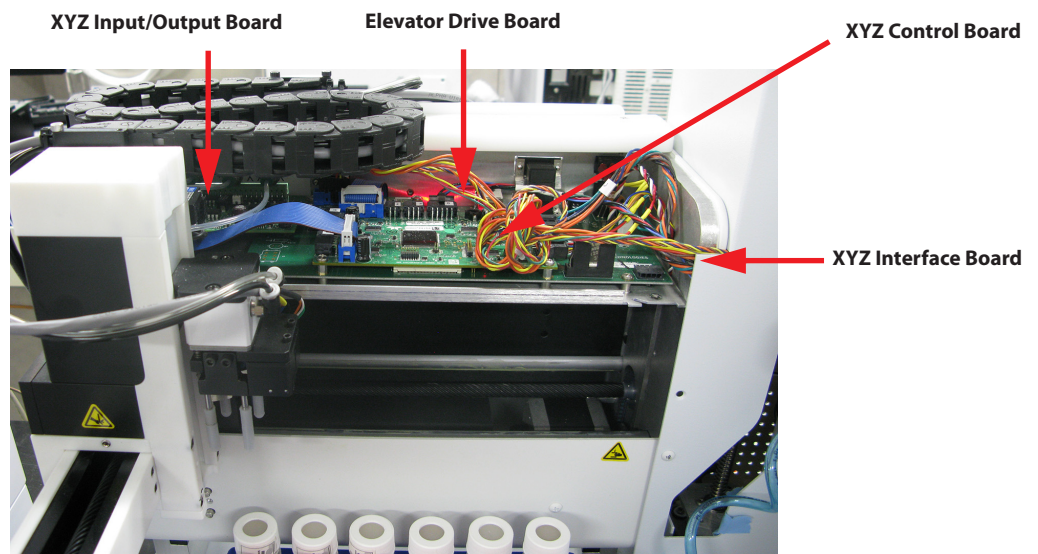

Figure 5-8 Printed Circuit Board Locations - Autosampler



### 5.7.2 CPU Communication Board (Master Board)

The CPU communication board (master board) is located on the right side of the Atomx XYZ. This board has a 25-pin, Sub-D connector for communications to the GC via GC I/O cable and USB Port for external communication to the controlling PC.

Figure 5-9 CPU Communication Board (Master Board)

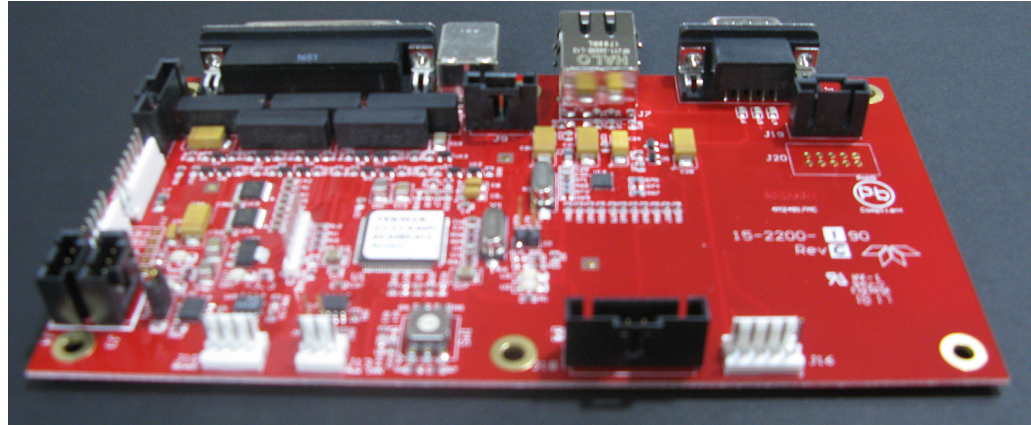
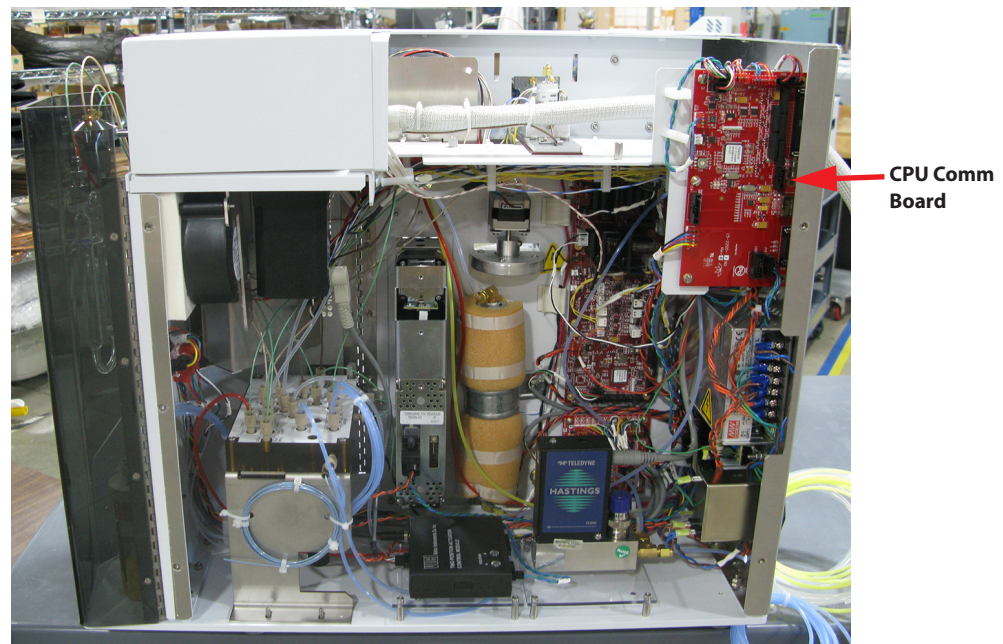

Figure 5-10 CPU Communication Board Location





### 5.7.3 Multi-Channel Temperature Control Board

The multi-channel temperature control board is located in the right side of the Atomx XYZ. This board is responsible for all AC control and RTD feedback for the standard temperature zones (6-Port valve oven, heated sample mount, heated analytical trap, sample transfer line heater, soil valve heater, sample vial cup heater and optional sample heater assembly for sparger glassware).

Figure 5-11 Multi-Channel Temperature Control Board

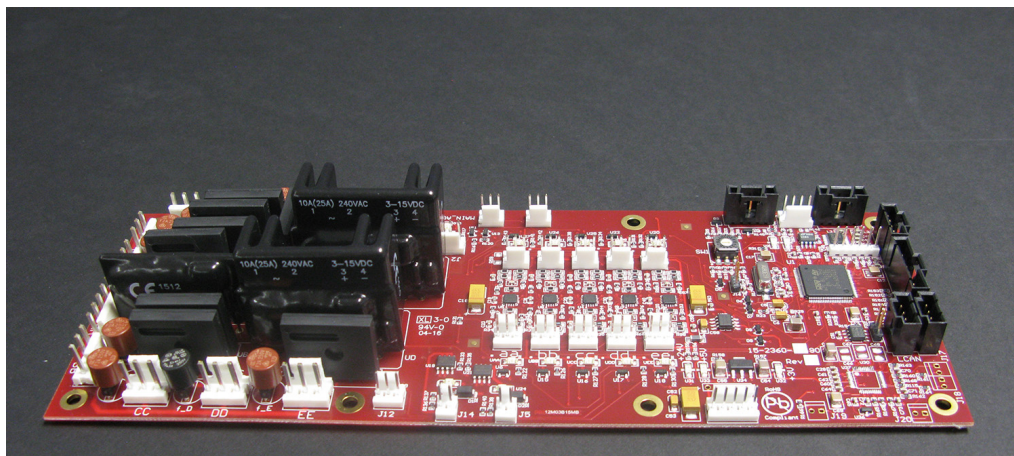
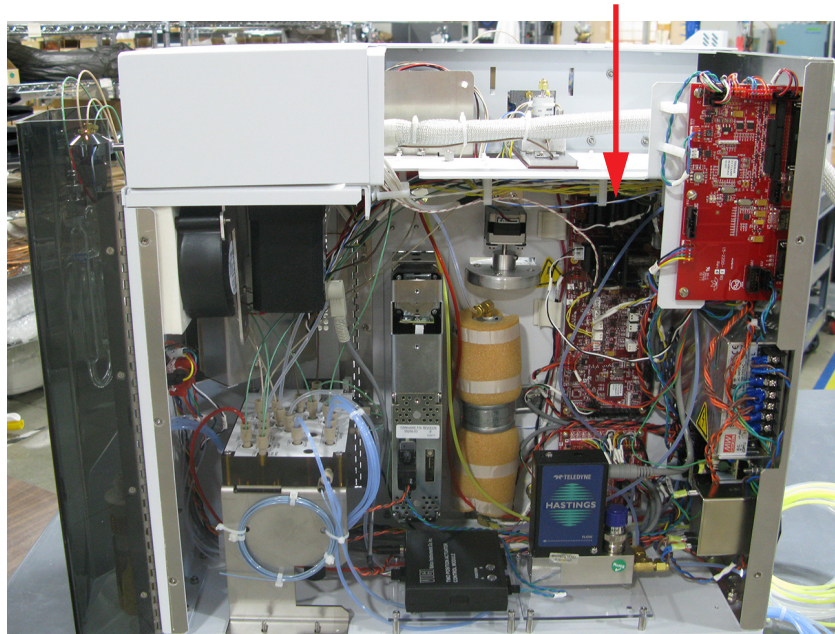

Figure 5-12 Multi-Channel Temperature Control Board

Multi-Channel Temperature Control Board







### 5.7.5 Internal Standard Valve Control Board

The internal standard valve control board is located in the right side of the Atomx XYZ. This board controls all internal standard valve outputs.

Figure 5-15 Internal Standard Valve Control Board

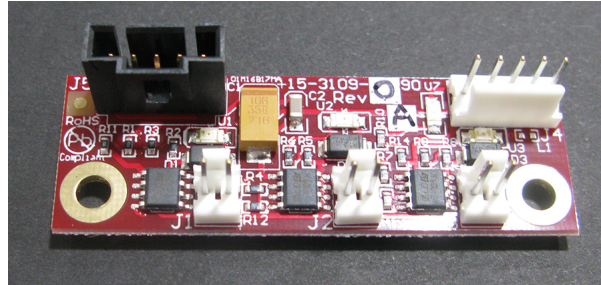
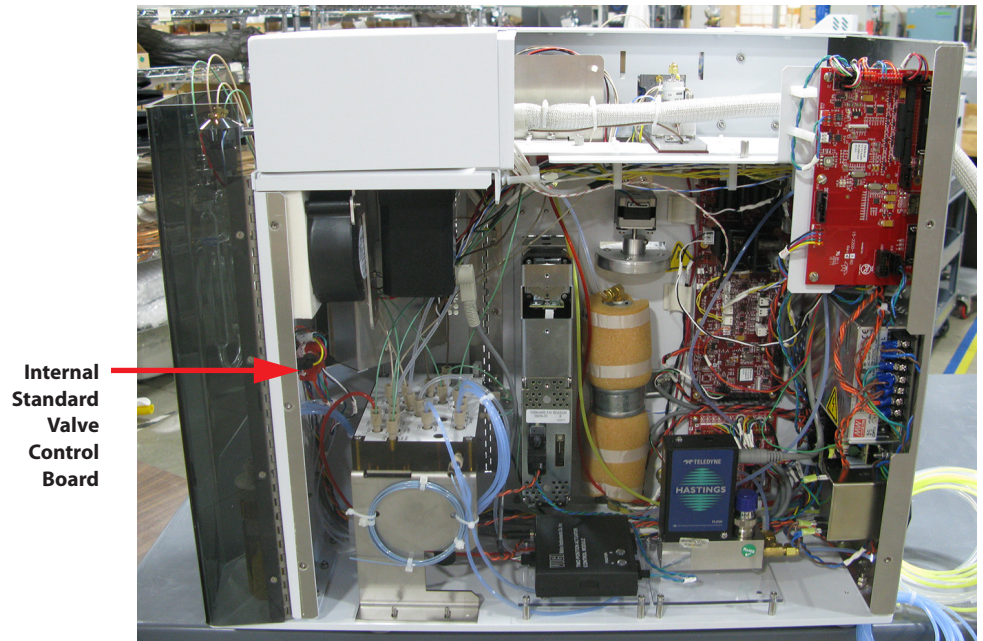

Figure 5-16 Internal Standard Valve Control Board Location



### 5.7.6 Banner Board/Status Light

The banner board is located in the marquis panel of the Atomx XYZ. This board controls the status light.

Figure 5-17 Banner Board Location



Figure 5-18 Banner Board

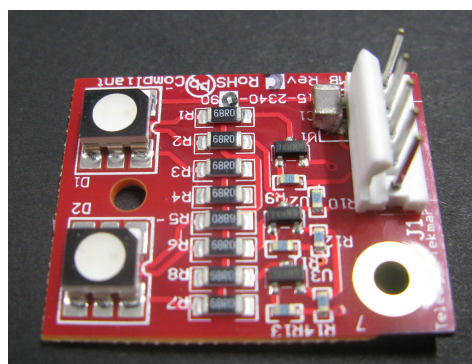

### 5.7.7 XYZ Interface Board

The XYZ interface board is located directly behind the autosampler arm and beneath the other autosampler boards. This board is responsible for communications between the XYZ control board and the autosampler arm.

Figure 5-19 XYZ Interface Board (Located Under the XYZ Input/Output and XYZ Control Board)

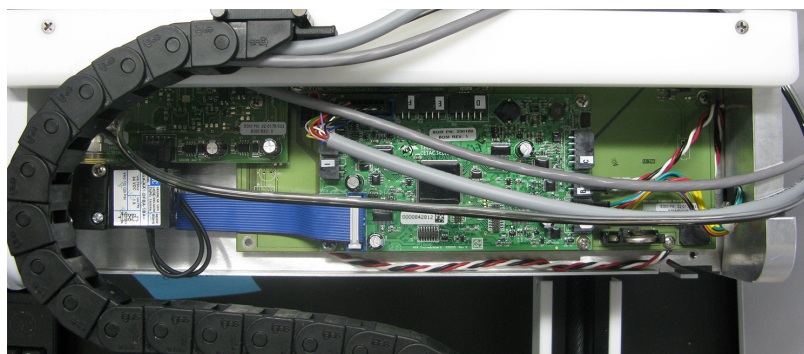





### 5.7.10 Elevator Drive Board

The elevator drive board is located on top of the XYZ interface board and is the small board in the back, center of the compartment. This board controls the up and down movements of the elevator.

Figure 5-22 Elevator Drive Board

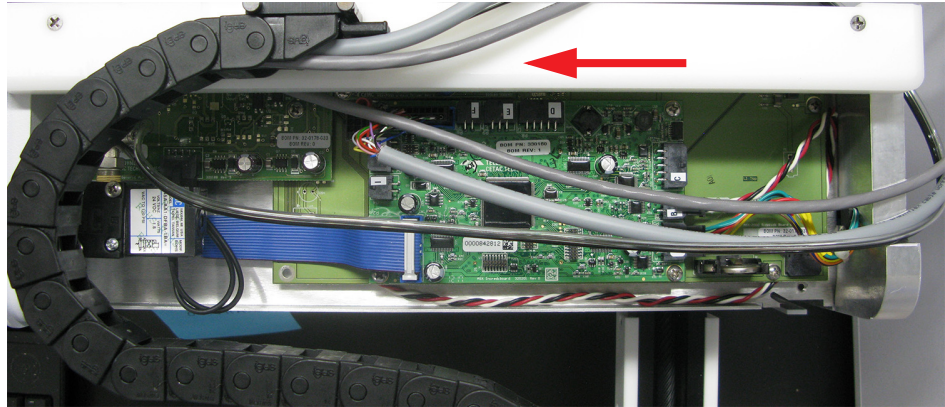

### 5.7.11 Power Supplies

#### 24VDC Power Supply

The 24VDC power supply is located on the back wall of the right side of the Atomx XYZ. The 24VDC power supply is identified by its brown/orange wiring. This power supply powers motors and valves within the Atomx XYZ including the 6-port valve and solenoid valves.

Figure 5-23 24VDC Power Supply

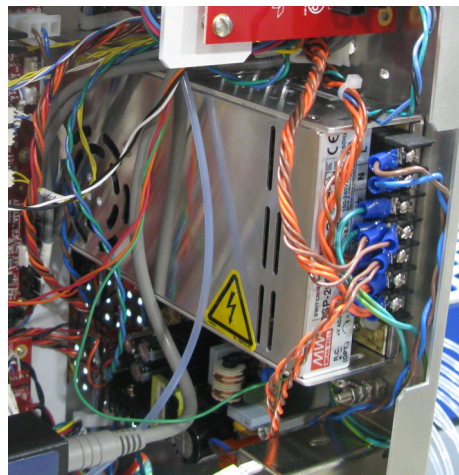

### 5VDC Power Supply

The 5VDC power supply is located on the back wall of the right side of the Atomx XYZ. The 5VDC power supply is identified by its black/red wiring. This power supply powers the status light and other boards within the Atomx XYZ (multi-channel temperature board, CPU communication board (master board), and DC valve control board, and XYZ main and interface boards).

Figure 5-24 5VDC Power Supply

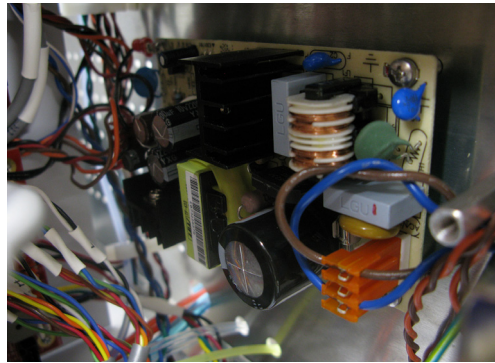

## 5.8 System Leak Check



### NOTE

The leak check settings are defined via TOOLS>CONFIGURATION>LEAK CHECK TAB.

Click TOOLS>LEAK CHECK to initiate the automated leak checking system. As the system moves through the leak check process, the INSTRUMENT STATUS PANEL is updated.

Figure 5-25 Leak Check Started

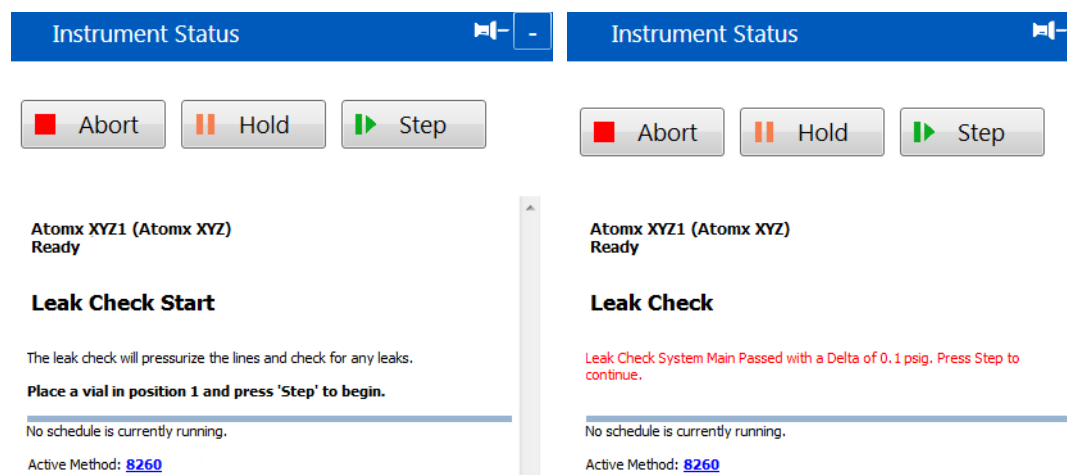



### 5.8.1 System Leak Check Flow Diagram

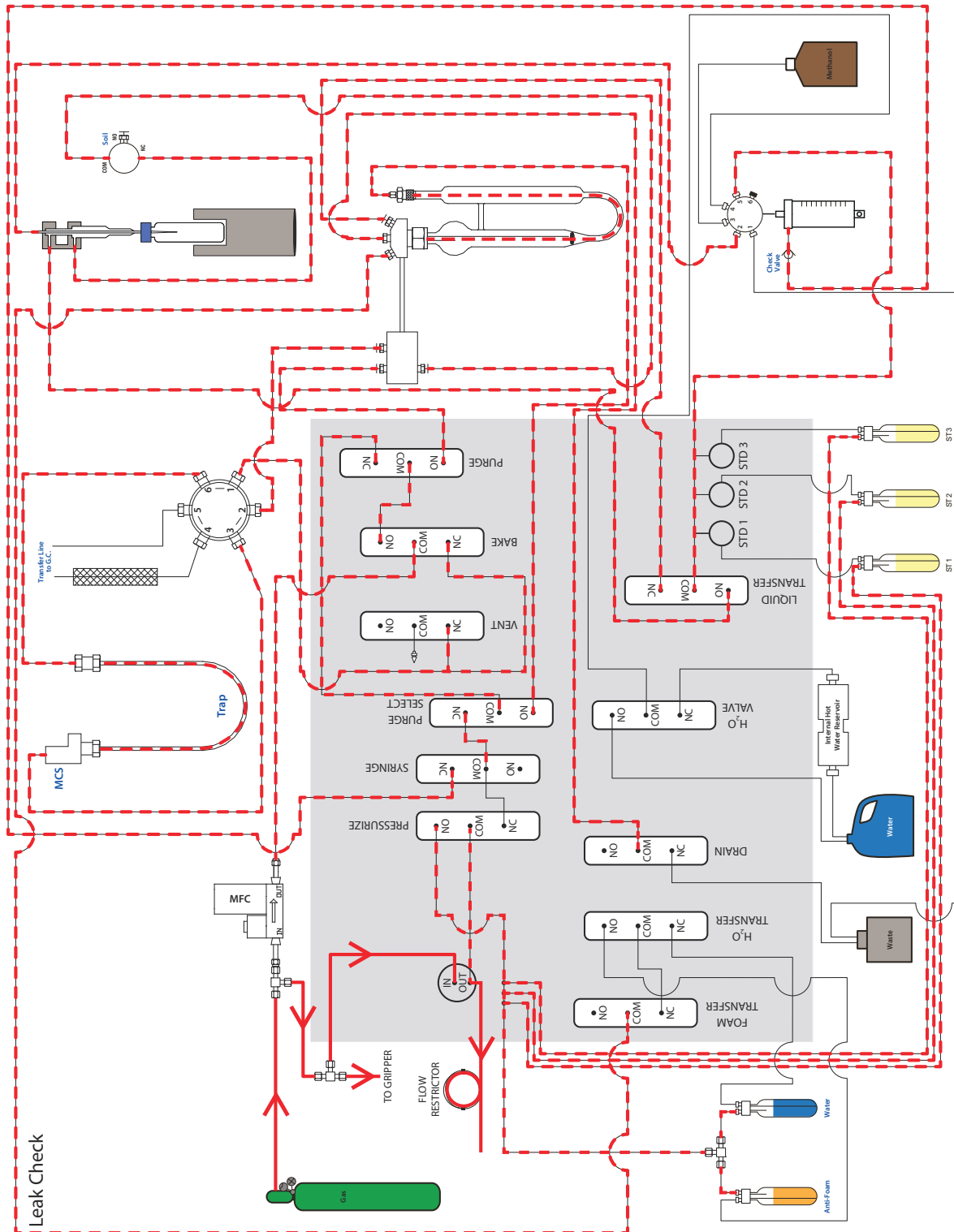

## 5.8.2 Leak Check Failed - Check Subsystem A

If the leak check fails, the system will automatically step to check Subsystem A. Flow will enter the Valve Manifold through the Bake Valve, continue through the Purge Valve and the Purge Select Valve, and stop within the manifold at the Syringe Valve and Pressurize Valve.

### **Subsystem A components include:**

- MFC
- Bake Valve (B)
- Purge Select Valve (E)
- Syringe Valve (G)
- Pressurize Valve (I)
- PEEK line connecting the Purge Valve and Purge Select Valve on the side of the manifold.

### **If the leak is in subsystem A the most like sources of the leak are:**

- MFC outlet fitting
- COM Port of Bake Valve (B)
- NC Port of Purge Valve (A)
- COM Ports of Purge Select Valve (E)

### 5.8.3 Subsystem A Leak Check Flow Diagram

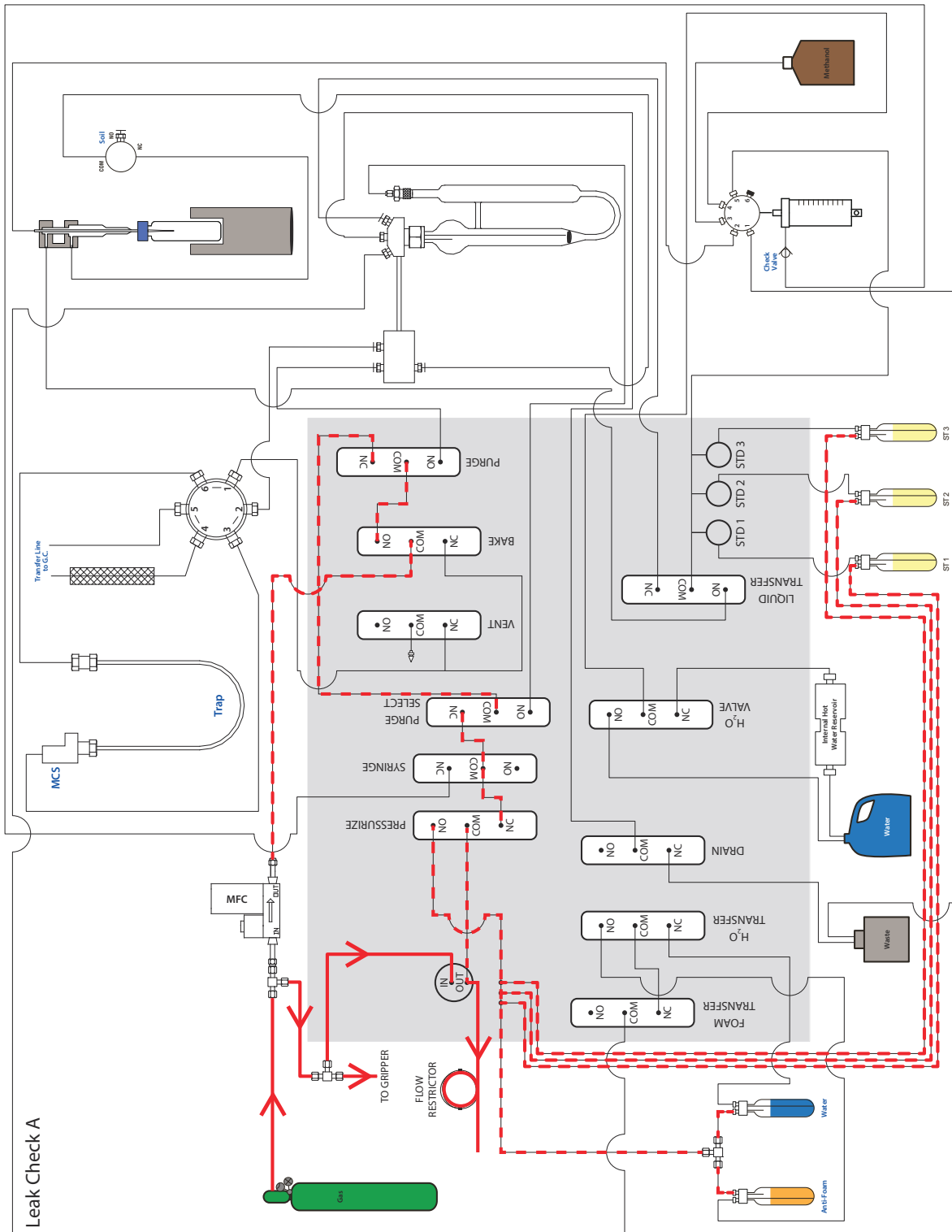

#### 5.8.4 Leak Check Failed - Check Subsystem B

If Subsystem A passes, the system is vented and re-pressurized to begin checking Subsystem B. This test is similar to Subsystem A, however the Syringe Valve (G) is actuated. The 6-Port Valve is rotated to the transfer line (5) to allow the vial to be pressurized. This test will essentially check subsystem A, but also includes the 6-Port Syringe Valve, Needle Fittings, and Soil Valve connections.

To isolate a syringe, 6-Port Syringe Valve, or Check Valve fitting leak, place a plug in port 5 of the 6-Port Syringe Valve and pressurize the system. If this passes, the Sample Vial is leaking, the Sample Needle fittings are leaking, or there is a leak at the Soil Valve (F).

**Subsystem B components include:**

- All subsystem A components
- Syringe
- 6-Port Syringe Valve
- Transfer Valve (H)
- Sample Needle
- Soil Valve (F)

**If the leak is in subsystem B the most likely places are:**

- Luer connection between the 6-Port Syringe Valve and Syringe
- Check valve port on the side of the 6-Port Syringe Valve
- COM or NO port of Transfer Valve (H)
- Fittings of the Sample Needle
- COM, NO, and NC port of Soil Valve (F)
- Sample Vial not leak tight.
- The internal standard injection valve ports on the Valve Manifold.

### 5.8.5 Subsystem B Leak Check Flow Diagram

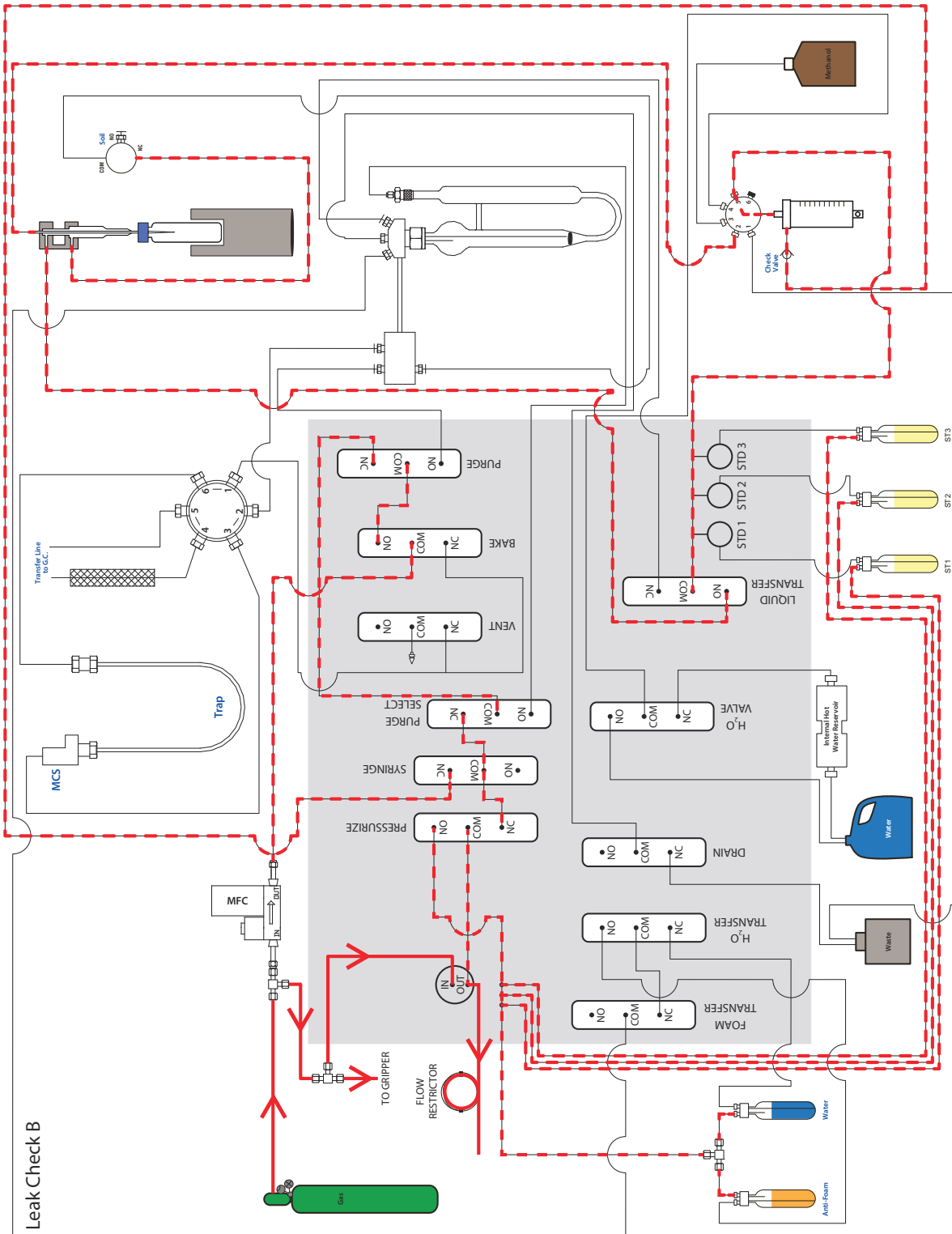

### 5.8.6 Leak Check Failed - Check Subsystem C

If Subsystem B passes, the system is vented again and re-pressurized to begin check of Subsystem C. This is a cumulative test, which will include Subsystem A and Subsystem B, but also will include the Sparge Vessel and the 6-port Valve. In this test the Soil Valve is actuated to allow pressure to flow through the 4-Way Tee, into the Sparge Vessel and through the 6-Port Valve.

**Subsystem C components include:**

- All Subsystem A components
- All Subsystem B components
- Sample Mount
- Sparge Vessel
- Drain Valve (D)
- Vent Valve (C)
- 6-Port Valve

**If the leak is in subsystem C the most likely places are:**

- Sparge Vessel fittings
- COM or cross-port leak of Drain Valve (D)
- COM or cross-port leak of Vent Valve (C)
- Sample Mount fittings (Plug, Drain Line, Transfer Line). Eliminator Line if installed.
- Sample Mount to 4-Way Tee fittings
- Sample Mount weldments
- 6-Port Valve (cross-port leak, loose fitting, loose rotor)

### 5.8.7 Subsystem C Leak Check Flow Diagram

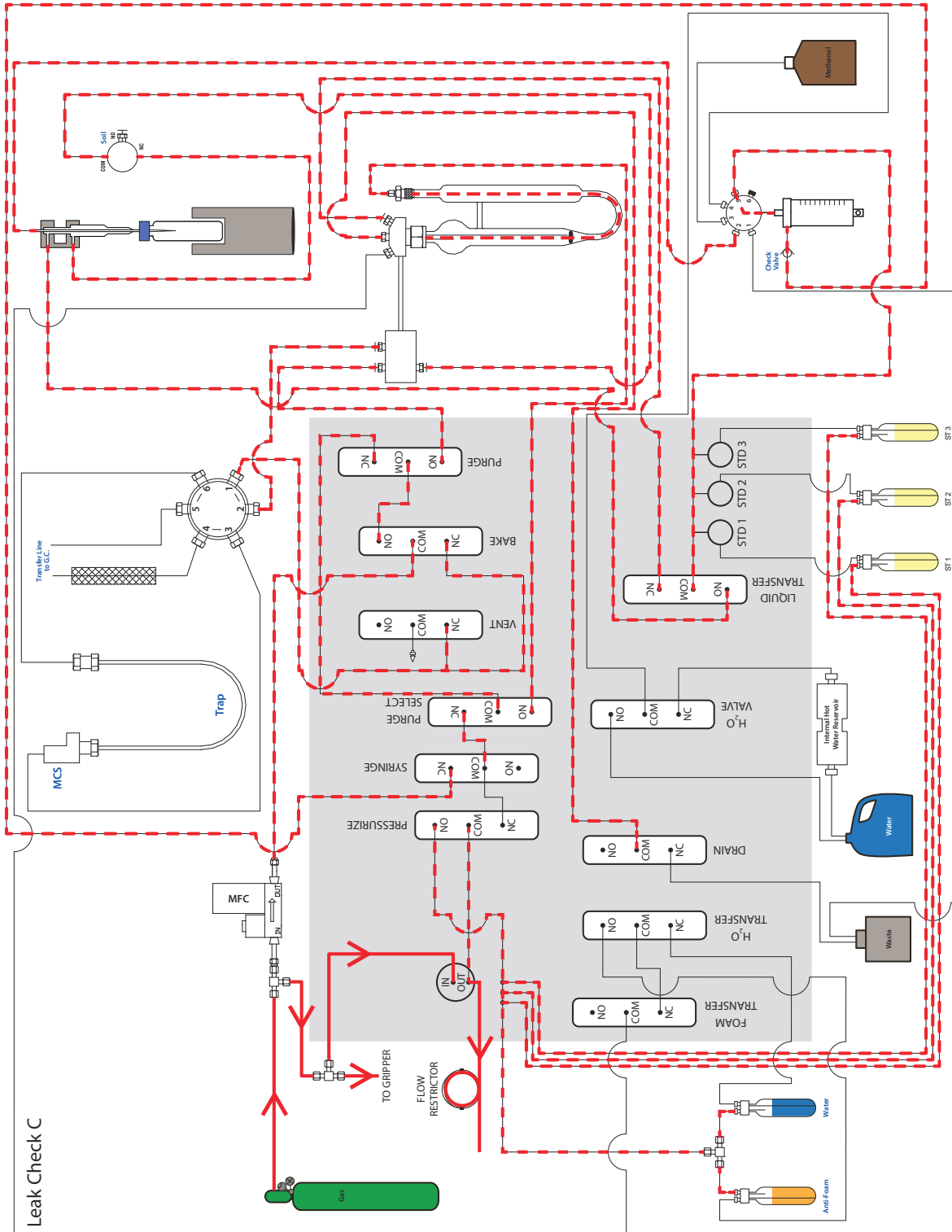



### 5.8.8 Leak Check Failed - All Subsystems Checked and Passed

If all subsystems pass the leak check and the whole system continues to fail, the leak can be isolated to the following areas:

- Trap Fittings
- MCS fittings
- Condenser fittings
- Loose fittings in the 6-port valve
- Potential cross-port leak in 6-port valve

## 5.9 Glassware Good Practices Cleaning Procedures

Clean glassware is essential for trouble-free analyses. This glassware includes spargers, samplers, flasks, cylinders - anything used in handling samples, standards, or blank water. Glassware used for other procedures, such as extractions, is usually not clean enough to use for trace applications.

Consult your laboratory's Standard Operating Procedures (SOPs) for keeping glassware clean. In addition to your standard glassware protocol Teledyne Tekmar recommends the following:

- Only clean glassware with DI water and do not use soaps or cleaning products which could introduce contamination.
- Use dedicated glassware. Dedicated glassware is glassware that is used for Atomx XYZ only.

### 5.9.1 Sparger Cleaning



Always wear safety glasses and appropriate Personal Protective Equipment (PPE) when working with Methanol. Consult the Methanol SDS and/or manufacturer's information for containment and cleanup methods and materials and disposal procedures.

Use a methanol rinse followed by DI water to clean contamination from the sparger.



#### NOTE

If sparger contamination cannot be removed, the sparger should be replaced.



#### Caution

When using Methanol, ensure it does not come into contact with any plastic or rubber instrument components.

## 5.10 Verifying/Setting Internal Standard Vessel Pressure

### 5.10.1 Verify the Internal Standard Vessel Pressure

1. Select the IS PRESSURE CHECK BUTTON on the TOOLS SCREEN to verify the internal standard vessel pressure. When the dialog is displayed, click the STEP BUTTON.

Figure 5-26 Instrument Status Panel - Check Standard Pressure

**Instrument Status**

Abort Hold Step

Atomx XYZ1 (Atomx XYZ)  
Ready

**Standard Pressurize**

To **check** standard pressure, press 'Step' to continue.  
To **set** standard pressure, adjust the pressure regulator to 0.0 psi by turning all the way counter clockwise and press 'Step' to continue.

No schedule is currently running.

Active Method: [8260](#)

Name	Current	Set Point
Mass Flow	10 mL/min	10 mL/min
Pressure	0.8 psig	n/a
Syringe	0.0 mL	0.0 mL
Transfer Line	139°C	140°C
Oven	140°C	140°C
Mount	88°C	90°C
Trap	26°C	Ambient
Sample Cup	25°C	Ambient
MCS	29°C	Ambient
Soil Valve	99°C	100°C
Water	89°C	90°C

2. Allow the system to depressurize, then click STEP again.
3. The standard pressure will then be displayed as the system pressure, under the ZONES FIELD in the INSTRUMENT STATUS PANEL. Click STEP again to return to normal operations.

## 5.10.2 Setting the Internal Standard Vessel Pressure

If the internal standard vessel pressure requires adjustment after verifying the pressure according to Section 5.10.1 "Verify the Internal Standard Vessel Pressure", perform the steps below.

1. Adjust the pressure regulator to 0.0 psi by turning the knob on the bottom of the regulator counter-clockwise until it stops.
2. Select TOOLS>CHECK STANDARD PRESSURE, click the STEP BUTTON.

Figure 5-27 Internal Standard Regulator Location on the Valve Manifold

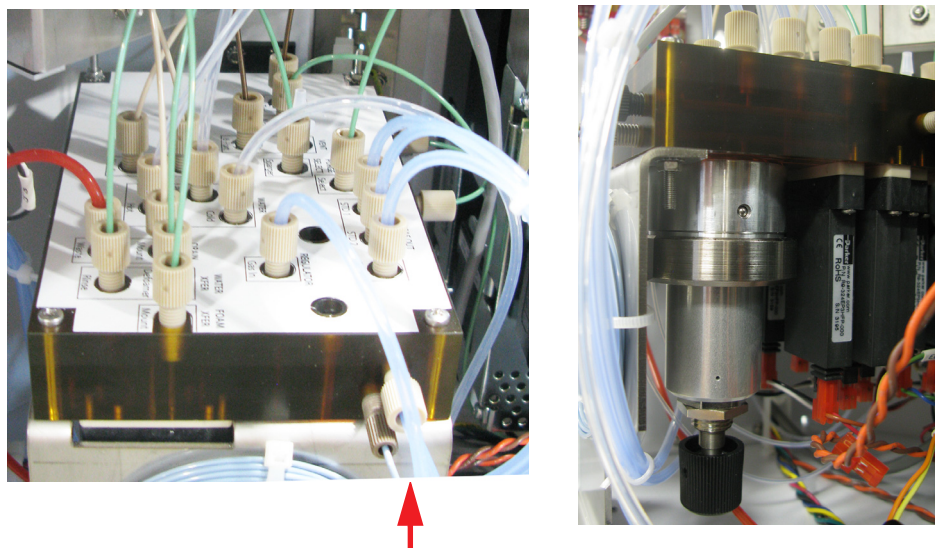

**Internal Standard Vessel Pressure Regulator is located under the Front/Right Corner of the Valve Manifold.**

3. Allow the system to depressurize, then adjust the pressure regulator by turning the knob on the bottom of the regulator clockwise until the pressure reading under the ZONES FIELD in the INSTRUMENT STATUS PANEL reads 7.0 psi.
4. Click STEP and allow the system to record the pressure in the INSTRUMENT HISTORY LOG (TOOLS>VIEW HISTORY LOG>INSTRUMENT HISTORY TAB). Normal operation of the instrument can then be resumed.

## 5.11 Sample Needle Replacement

Figure 5-28 Sample Needle

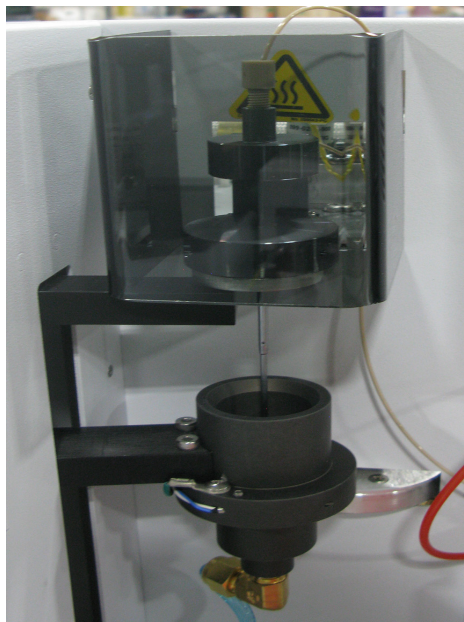

**Warning!** Ensure the instrument is powered off, and the AC power cable removed prior to placing hands and/or other appendages in the path of travel of the XYZ autosampler arm.

### 5.11.1 Tools and Supplies

- Replacement Sample Needle Assembly
- Phillips-head Screwdriver
- 1/4" Open-ended wrench

### 5.11.2 Procedure

1. Power off the Atomx XYZ and remove the AC power cable from the back of the instrument.
2. Remove the protective cover over the sample needle.
3. Disconnect the tan purge gas tubing at the top of the needle. Next, use a 1/4" open-ended wrench to disconnect the 1/16" stainless steel Inertium® liquid transfer tubing, and 1/16" stainless steel Inertium soil valve tubing at the back of the needle.

Figure 5-29 Tubing Connections at the Sample Needle Assembly

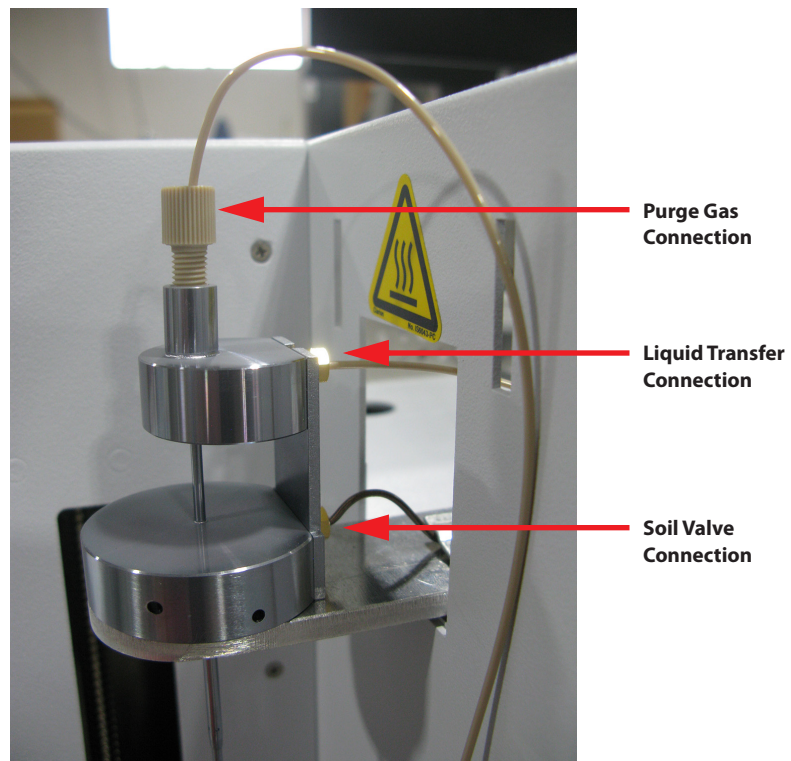

4. Loosen the two phillips-head screws (located underneath the needle mount) that secure the needle assembly to the needle mount.
5. Place the new needle assembly on the needle mount and then secure it using the two previously removed phillips-head screws.
6. Reconnect the tan purge gas tubing at the top of the needle, the 1/16" stainless steel Inertium liquid transfer tubing, and 1/16" stainless steel Inertium soil valve tubing at the back of the needle. Tighten the fittings, but do not over-tighten.
7. Reinstall the protective cover over the sample needle.
8. Connect the AC power cord and turn the unit ON.
9. Start the Atomx XYZ TekLink software, if necessary.
10. Perform a leak check according to Section 5.8 "System Leak Check".

## 5.12 Sparger Replacement



### NOTE

For sparger cleaning refer to Section 5.9.1 "Sparger Cleaning".

#### Tools Required

- 1/2" Open-ended Wrench
- 9/16" Open-ended Wrench
- 7/8" Open-ended Wrench

#### Procedure



**Warning! Hot surface! Turn OFF power to the Atomx XYZ and remove the AC power line from the back of the instrument. Allow the sample mount and surrounding area to cool to room temperature.**

Figure 5-30 Sparger Connections

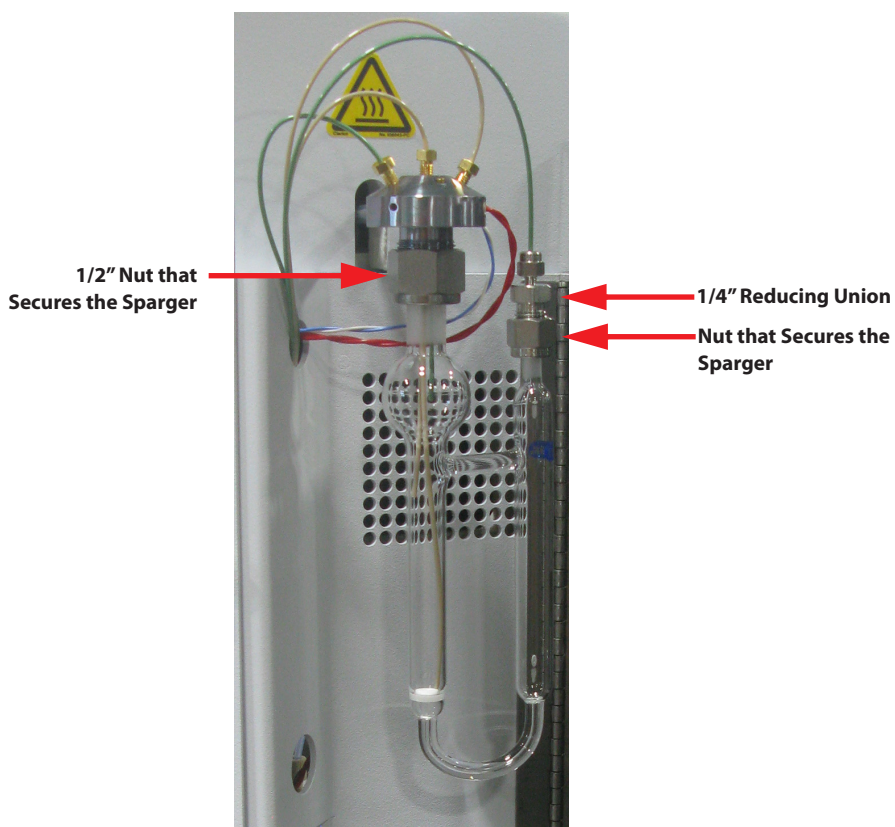

1. Power off the Atomx XYZ and remove the AC power cable from the back of the unit. Allow the sample mount and surrounding areas to cool.
2. Open the sparger panel door on the front of the Atomx XYZ.

**NOTE**

The guard has a keyhole slotted hinge that can be removed by lifting the guard up and out if necessary.

3. Begin with the small diameter side of the U-shaped sparger glassware. Place a 1/2" wrench on the 1/4" reducing union and then loosen the nut above the sparger with a 9/16" wrench. Slide the union off of the glassware neck (Figure 5-30).
4. Support the glassware in one hand and loosen the 1/2" nut below the sample mount using a 7/8" wrench (Figure 5-30). Once the nut is loose, slide the glassware out of the sample mount.
5. Install the new sparger by sliding it into the 1/2" nut attached to the bottom of the sample mount. Insert the glassware completely and tighten the nut just enough to allow it to hold the glassware without manual support. Twist the glassware so that the glassware is backed off the mount 1 mm-2 mm. Finger-tighten the nut then use a 7/8" wrench to tighten further, no more than a 1/2 turn.
6. Reconnect the union on the small diameter side of the U-shaped glassware and finger-tighten the nut. Hold the 1/4" reducing union with a 1/2" wrench, then tighten the nut above the sparger with a 9/16" wrench turning it no more than a 1/2 turn.
7. Connect the AC power cord and turn the unit ON.
8. Start the Atomx XYZ TekLink software, if necessary.
9. Perform a leak check according to Section 5.8 "System Leak Check".



## 5.13 Analytical Trap Replacement



### NOTE

After the trap is installed, condition it prior to analysis according to Section 5.14 "Analytical Trap Conditioning".

#### Tools Required

- 3/8" Open-ended Wrench
- 7/16" Open-ended Wrench

Figure 5-31 Analytical Trap Compartment

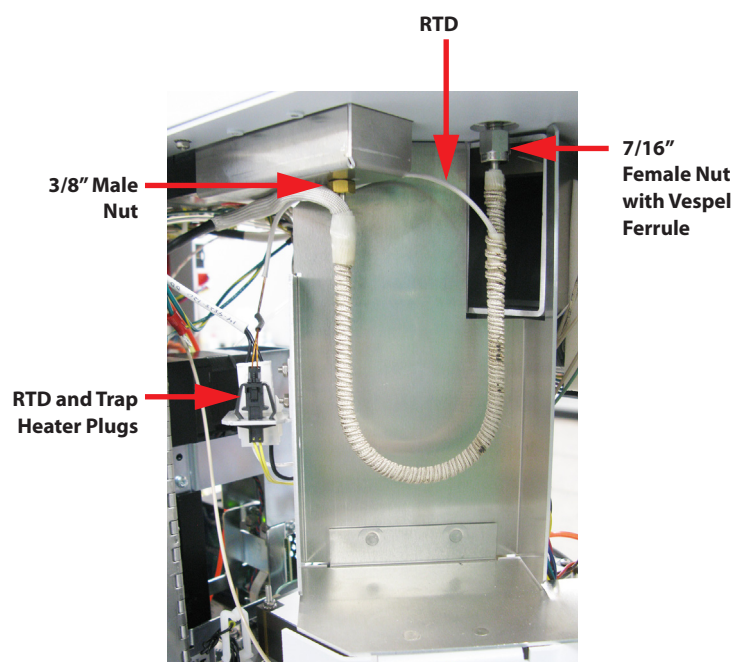

#### Procedure



**Warning! Hot surface! The trap and surrounding areas can be extremely hot. Allow adequate time to cool.**



**Warning! To avoid electrical shock turn OFF and unplug the Atomx XYZ before servicing.**

1. Power off the Atomx XYZ and remove the AC power cable from the back of the unit. Allow the sample mount, analytical trap and surrounding areas to cool.
2. Open the analytical trap compartment door.
3. Disconnect the trap heater and RTD plugs at the left side of the trap compartment.

Figure 5-32 Trap Heater Orientation and RTD Plugs

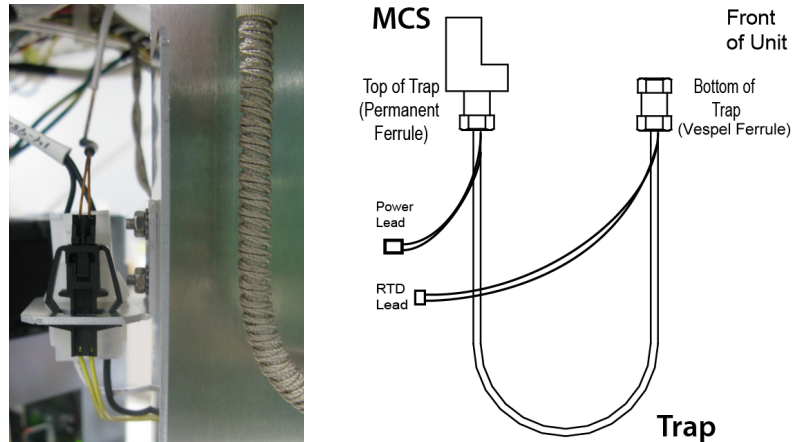

4. The analytical trap is connected at the top of the compartment using a 3/8" male nut on one side and a 7/16" female nut on the other. Using an open-ended wrench, loosen both nuts and remove the analytical trap.
5. Remove and retain the 7/16" nut and Vespel<sup>®</sup> ferrule from the right side of the analytical trap.
6. Carefully slide the trap out of the heater jacket with RTD.
7. Remove the protective end covers on the new trap.
8. Slide the trap heater jacket and RTD onto the new trap **with the RTD oriented toward the side with the 7/16" female nut**. After installation, the RTD should be orientated to the right side of the compartment, when facing the unit (Figure 5-32).
9. Place the 7/16" nut, then the Vespel<sup>®</sup> ferrule, cone oriented upward, over the end of the trap.
10. Reattach the new trap at the top of the compartment. The 7/16" nut and vespel ferrule should be oriented to the right. Tighten, but do not over-tighten.



### NOTE

Ensure the trap is installed in the correct direction. Refer to Figure 5-32.

11. Reconnect the trap heater and RTD plugs at the left side of the trap compartment.
12. Close the analytical trap compartment door.
13. Connect the AC power cord and turn the unit ON.
14. Start the Atomx XYZ TekLink software, if necessary.
15. Perform a leak check according to Section 5.8 "System Leak Check".
16. Condition the analytical trap according to Section 5.14 "Analytical Trap Conditioning".

## 5.14 Analytical Trap Conditioning



### NOTE

Also refer to the trap manufacturer's instructions for conditioning.

### 5.14.1 Analytical Trap Recommended Conditioning Settings

**Table 5-7 Analytical Trap Recommended Conditioning Temperatures and Times**

Description	Part #	Conditioning Temperature (°C)	Conditioning Time (Min)
(#1) Tenax®	12-0083-403	225	180
(#1A) Tenax® <sup>a</sup>	12-0083-503	225	180
(#2) Tenax®/Silica Gel	12-0084-403	225	180
(#3) Tenax®/Silica Gel/Charcoal	14-0124-403	225	180
(#4) Tenax®/Charcoal	14-1457-403	225	180
(#5) OV®-1/Tenax®/Silica Gel/Charcoal	14-2366-403	225	180
(#6) OV®-1/Tenax®/Silica Gel	14-1755-403	225	180
(#7) OV®-1/Tenax®	14-3347-403	225	180
(#8) Carbo-pack™ B/Carbosieve® S-III	14-3928-403	260	90
(#9) Trap (Proprietary)	14-9908-403	270	120
(#10) Tenax®/Silica Gel/Carbosieve® S-III	14-9909-403	225	180
(#11) VPH Trap (Proprietary)	15-0884-403	270	120
(K) Vocarb® 3000	14-5864-403	270	120
Vocarb® 4000	14-5865-403	270	120
BTEX™	14-5866-403	270	120
BTEX™ + MTBE	14-9333-403	270	120

a. Uses a different mesh size.

### 5.14.2 Procedure

1. From the HOME SCREEN select the TOOLS BUTTON to display the TOOLS SCREEN. Select the Go To BAKE BUTTON to display the BAKE DIALOG.
2. In the BAKE DIALOG, enter the recommended trap conditioning settings from the trap manufacturer.
3. Select the OK BUTTON to begin conditioning the trap.

Figure 5-33 Bake Dialog

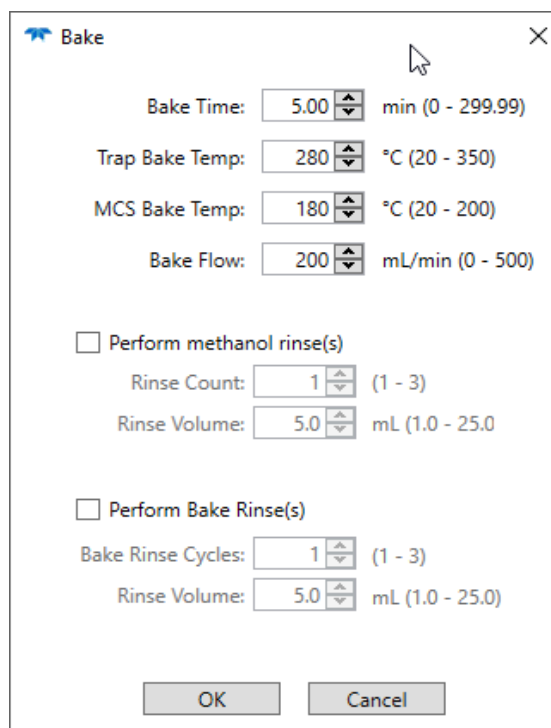

## 5.15 Elevator Lubrication



**Warning!** The instrument must be powered and the elevator moving for the lubrication procedure. Allow the elevator to come to a full stop before applying lubricant. Do not place hands and/or other appendages in the path of travel of the elevator while it is moving.

### 5.15.1 Tools and Supplies

- Dupont™ Krytox® Grease

### 5.15.2 Procedure

1. Select the TOOLS BUTTON on the HOME SCREEN. Select the VIALS/ELEVATOR BUTTON to display the XYZ ARM DIAGNOSTICS SCREEN. Select DOWN from the ELEVATOR DESTINATION MENU and then select the MOVE BUTTON. Allow the elevator to move to the down position and stop.

Figure 5-34 Elevator Down

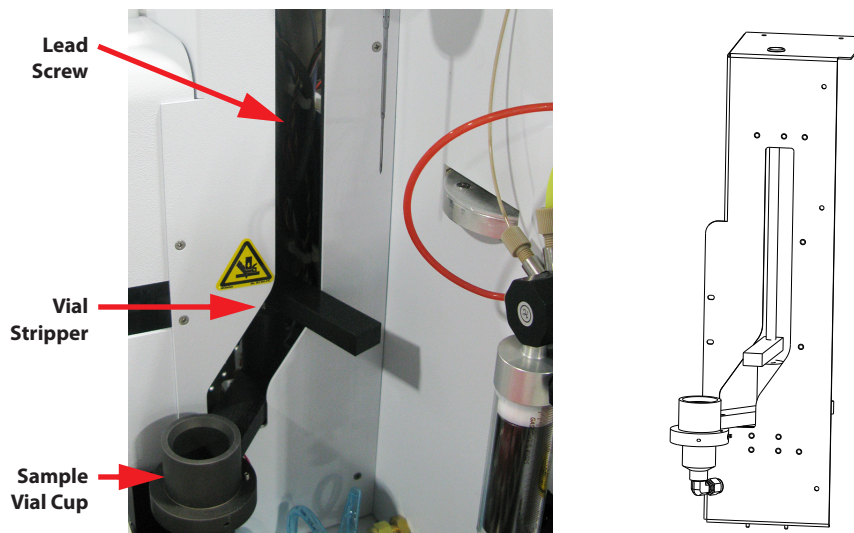

2. Apply a small amount of Krytox grease to the vertical center of the elevator lead screw.
3. Select UP from the ELEVATOR DESTINATION MENU and then select the MOVE BUTTON. Allow the elevator to move to the up position and stop.
4. Once again apply a small amount of Krytox grease to the vertical center of the elevator lead screw.
5. Select DOWN from the ELEVATOR DESTINATION MENU and then select the MOVE BUTTON. Allow the elevator to move to the down position. By moving the elevator up and down the grease will be evenly distributed along the lead screw.

## 5.16 XYZ Autosampler Alignment



### NOTE

The autosampler's alignment can be tested at any time using the Alignment Test Button on the Begin Alignment Screen of the Autosampler Alignment Wizard. Select Tools>Align Autosampler Button.



### NOTE

The gripper is a pneumatic device and requires the instrument to be connected to the sample gas to function. If the gripper is not functioning correctly, first ensure the sample gas supply is on, properly connected, and supplying 65 - 100 psi (4.48 bar -6.89 bar) to the Atomx XYZ.

### 5.16.1 When is Alignment Needed?

The autosampler may need alignment if:

- The vial gripper is unable to locate, grasp, transport and/or place the vial in the sample vial cup.
- The vials knock against the edge of the autosampler vial rack openings or the edge of the elevator sample vial cup.
- A motor or lead screw has been replaced.
- The XYZ autosampler has been subjected to extreme shock or vibration.

### 5.16.2 Alignment Overview



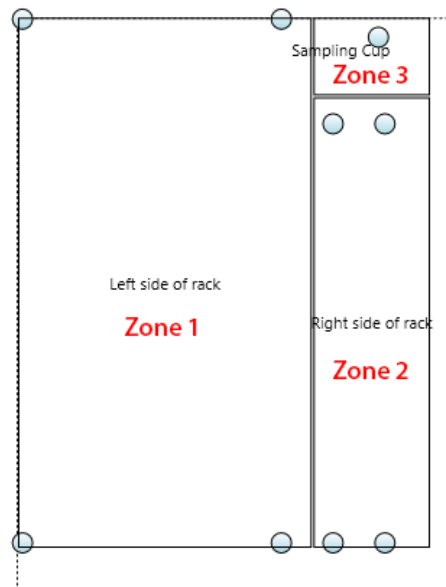

The AUTOSAMPLER ALIGNMENT WIZARD is used to align and test the X, Y and Z-axis of the autosampler arm. When the alignment procedure is begun, the current alignment is disabled. The wizard then sequentially performs the X, Y and Z-axis alignment of the autosampler vial rack's three zones (Figure 5-35).

Figure 5-35 Autosampler Zones



For zones 1 and 2, three landmarks per zone are manually aligned using an alignment probe and target placed in the landmark position. The fourth landmark (the last corner of the zone) is then calculated and tested. The X and Y-axis of the single alignment landmark of Zone 3, the sample vial cup, is then aligned using the probe and target and tested.

As the alignment progresses, the autosampler zone diagram of the AUTOSAMPLER ALIGNMENT WIZARD will update the color of each alignment landmark to indicate its status. Status colors are shown in Table 5-8 "Alignment Landmark Color Codes".

Table 5-8 Alignment Landmark Color Codes	
	Location of an alignment landmark.
	Location of an alignment test point (tested when the Test Alignment Button is selected). Test points are not manually aligned; they are calculated from the previous alignment landmark coordinates.
	Location of the current alignment landmark.
	Alignment completed.

Once the X and Y-axis alignment is completed for all zones, the wizard will then align the Z-height axis using an actual vial with cap and septa. Once the alignment has been completed, the coordinates are then programmed into the autosampler and enabled. The alignment can then be validated using a test in which a vial is moved to various positions on the autosampler vial rack.



Once an alignment is initiated, all zones and axis must be completed. It is possible to exit and re-enter the wizard and use the Align Zone Buttons or Z-Height Alignment Button to advance to the necessary alignments requiring completion.

### 5.16.3 Tools and Supplies

- Alignment Target
- Alignment Probe
- 40 mL Vial with lid and septa

### 5.16.4 Procedure



**Warning! The instrument must be powered and the XYZ autosampler arm moving for the alignment procedure. Do not place hands and/or other appendages in the path of travel of the XYZ autosampler arm.**

1. Ensure the autosampler vial rack is fully seated in the rack locator slots, and all vial positions, including the sample vial cup, are empty.



2. Select the **ALIGN AUTOSAMPLER BUTTON** on the **TOOLS SCREEN** to open the **AUTOSAMPLER ALIGNMENT WIZARD**.

Figure 5-36 Atomx XYZ TekLink Tools Screen and Align Autosampler Button

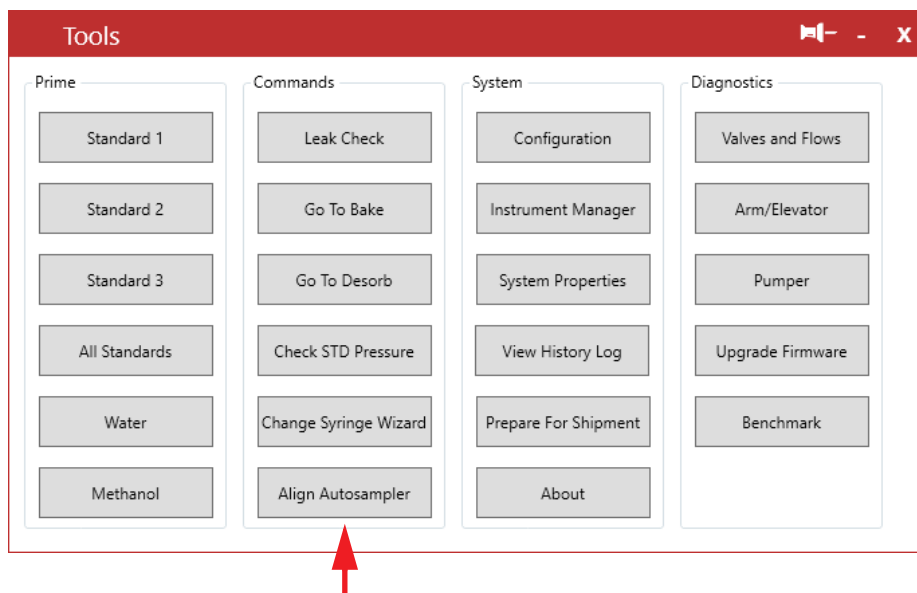

3. The **AUTOSAMPLER ALIGNMENT WIZARD** will be displayed and prepare for the alignment by disabling all current alignment corrections. When the wizard is ready for the alignment procedure, the **NEXT BUTTON** will be enabled. Select the **NEXT BUTTON** to advance to the **ALIGN ZONE 1 PAGE**.



Use the individual Align Zone Buttons to advance to a specific zone, or the Z-Height Alignment to advance to aligning the gripper height.

Figure 5-37 Autosampler Alignment Wizard - Ready to Begin Alignment

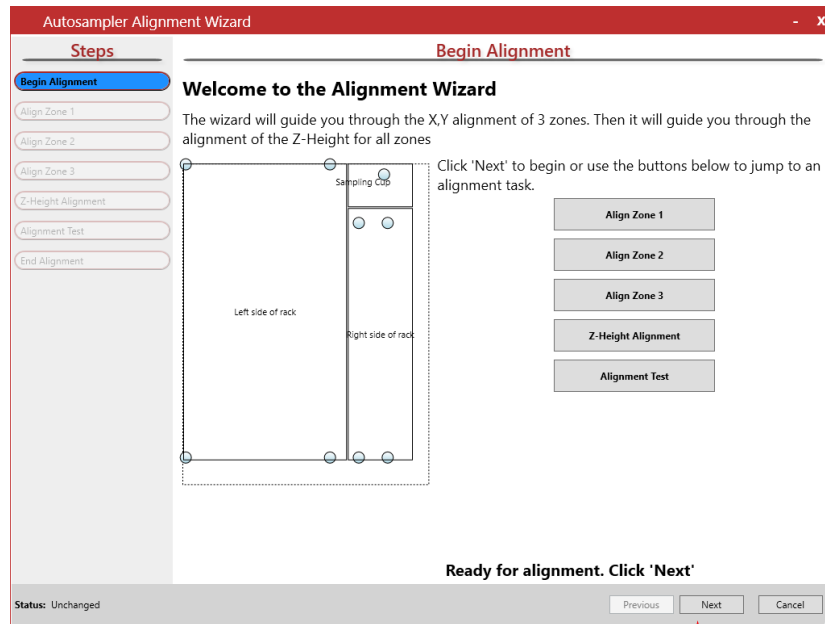

4. On the ALIGN ZONE 1 PAGE use the gripper controls to place the alignment probe into the gripper. Use the OPEN GRIPPER BUTTON  to open the gripper and place the probe inside the gripper.

Use the CLOSE GRIPPER BUTTON  to close the gripper around the probe as shown in Figure 5-39.

Figure 5-38 Align Zone 1 - Gripper Controls

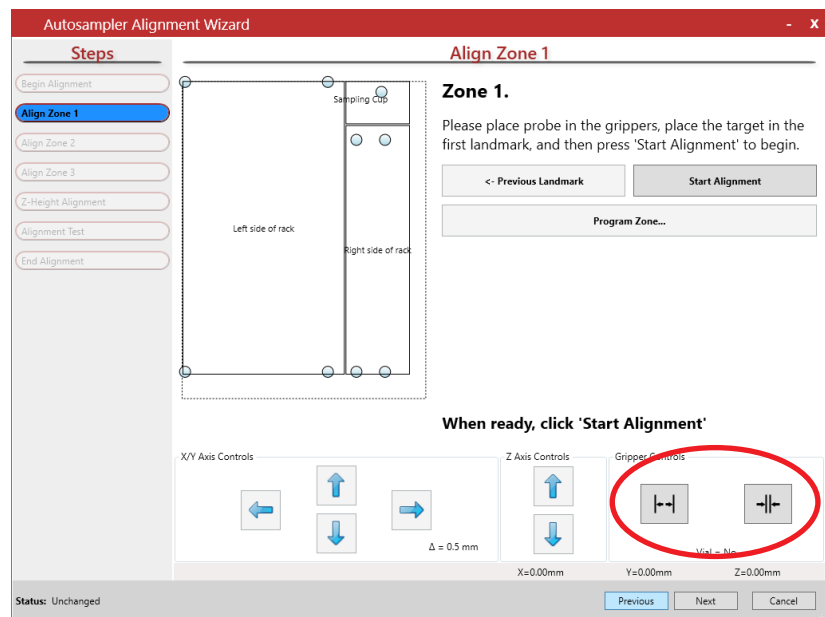
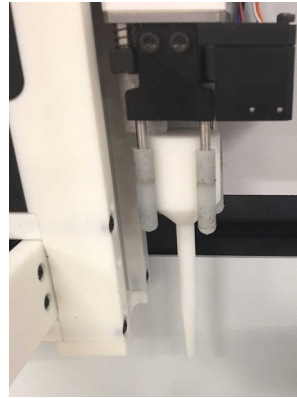
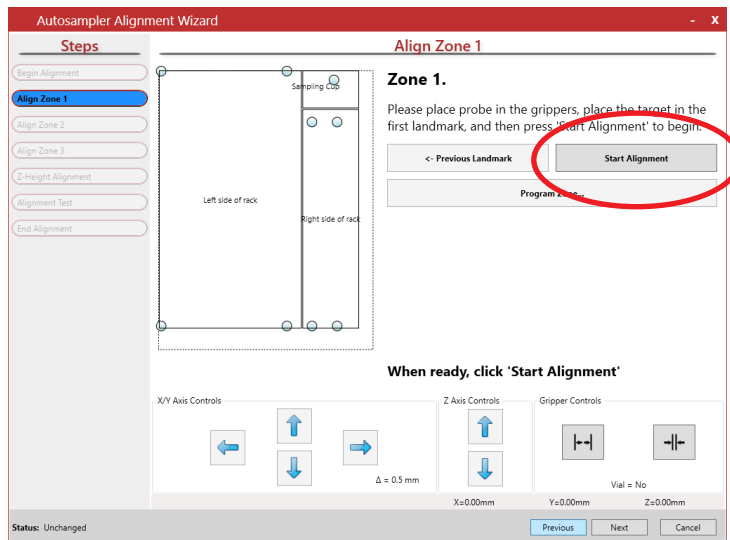

Figure 5-39 Probe in Gripper



5. With the probe installed in the gripper, select the START ALIGNMENT BUTTON.

Figure 5-40 Align Zone 1 - Start Alignment Button



6. The autosampler will move the gripper over the first alignment landmark indicated by a purple dot on the autosampler vial rack diagram. The wizard will then display a user prompt to place the alignment target in the corresponding location (Figure 5-41). Once the target is in place, click the OK BUTTON on the dialog. The probe will descend to a position just above the target (Figure 5-41).

Figure 5-41 Align Zone 1 - Place Target

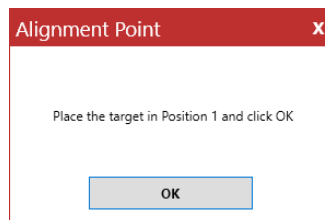

- Use the X/Y-AXIS CONTROLS to align the probe over the opening in the target. Use the Z AXIS CONTROLS to move the probe into the target opening. When properly aligned, the probe will fit into the target with an equal amount of space on all sides. It is generally adequate to visually center the probe without measurement.

The current x, y and z coordinates of the probe are shown in the bottom, right-hand corner of the screen. As the probe is moved, these values will briefly be displayed in red indicating that the probe has moved, but the instrument has not reported the new value back to the wizard. The text will change back to black once the instrument reports the new position to the wizard.



The distance the probe moves is defined by the  $\Delta = \text{mm}$  Field beneath the control boxes. Right-click on the field to decrease the distance, left-click to increase the distance.

Figure 5-42 Probe Alignment Buttons

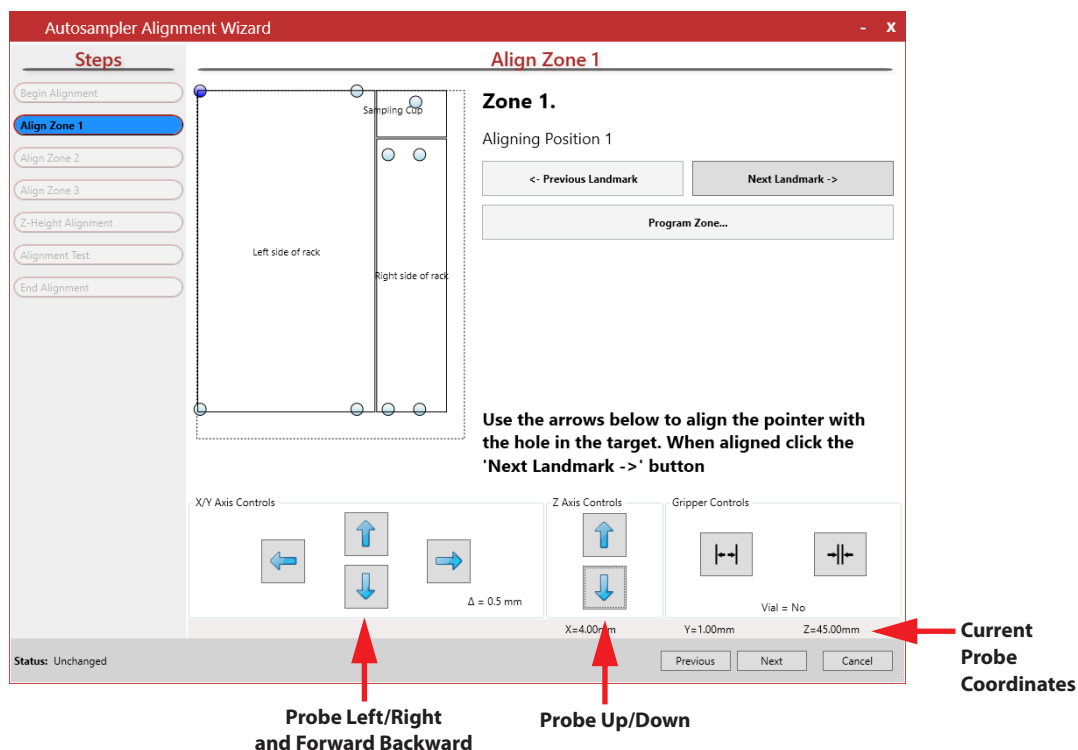
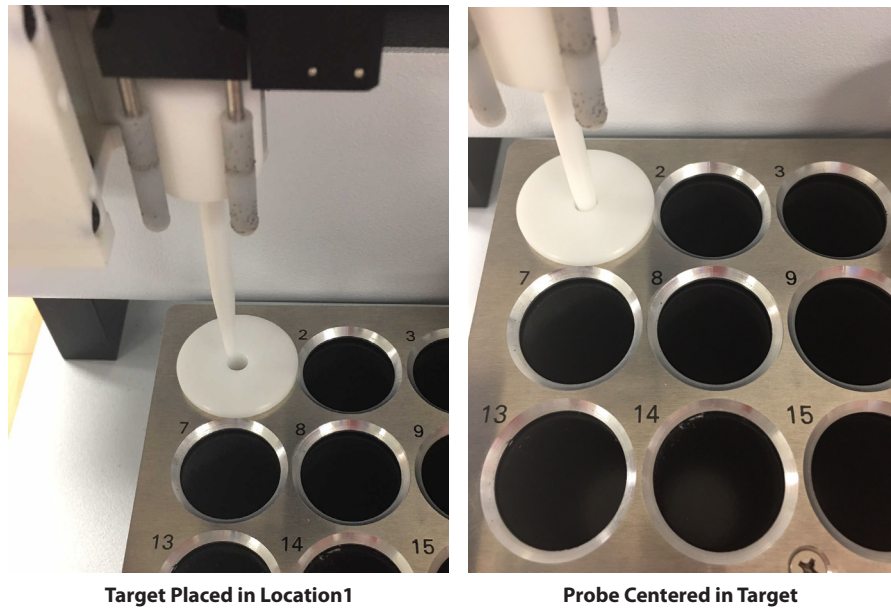
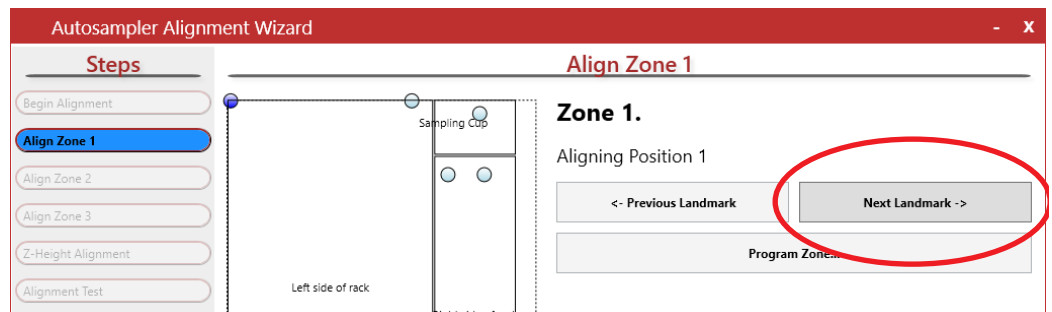

Figure 5-43 Target in Location 1



8. Once the probe is correctly aligned in the target, click the NEXT LANDMARK BUTTON. The wizard will repeat steps 5 to 7 for the next two landmarks.

Figure 5-44 Align Zone 1 - Next Landmark Button



9. Once the third landmark in the zone has been aligned, select the TEST ALIGNMENT BUTTON. The wizard will calculate the correction values for Zone 1 and then apply them to the landmarks.

Figure 5-45 Align Zone 1 - Test Alignment

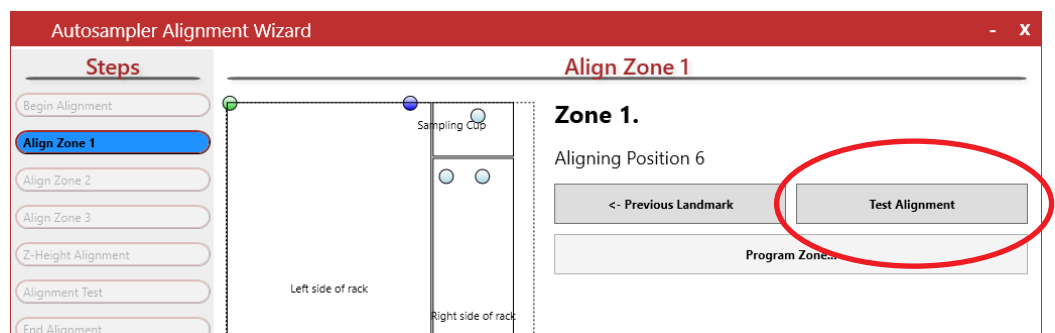

The wizard will then move the probe to the test point (the fourth corner of the zone) and prompt for placement of the alignment target.

Figure 5-46 Align Zone 1 - Prompt to Place Target in Landmark Four

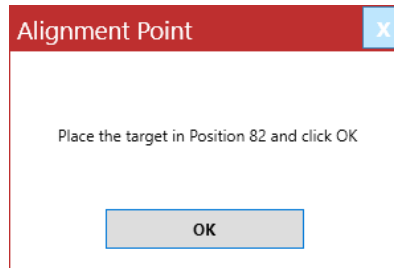

Once you have placed the target in the test point, click the OK BUTTON. The wizard will then lower the probe over the test point so that alignment can be verified. The probe should be close to the center of the alignment target, and pass into the center hole of the target. The wizard's Z AXIS CONTROLS may be used to lower the probe for visual confirmation. The alignment does not have to be perfect. As long as the probe can enter the hole of the target, the alignment will be adequate.

If the alignment of the probe to the alignment target requirements adjustment, use the PREVIOUS LANDMARK BUTTON to realign the previous landmarks again and then retest.

Figure 5-47 Align Zone 1 - Checking Landmark 4

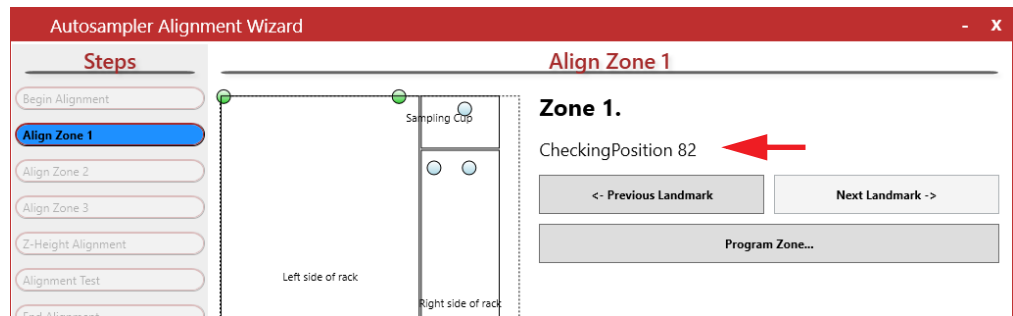

If the calculated value for one of the landmarks falls outside the bounds of the autosampler, an error notification will be displayed. Use the PREVIOUS LANDMARK BUTTON to repeat the landmark alignments.

Figure 5-48 Alignment Error

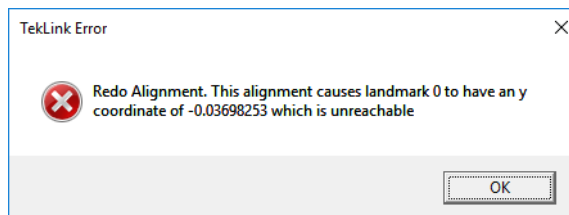

**NOTE**

If realignment fails to resolve the test point misalignment, note the coordinates at the bottom, right-hand corner of the screen. The minimum uncorrected x, y position is 0, 0 and the maximum is 254.0, 360.0. If any of the aligned points are at the minimum or maximum, contact Teledyne Tekmar Customer Support using the contact information in Section P.2 "Teledyne Tekmar Customer Support Center" and request an "Origin Alignment" for the autosampler.

10. If the alignment is OK, select the PROGRAM ZONE... BUTTON to save the X and Y correction factors to the autosampler. Once completed, the wizard will prompt to click the NEXT BUTTON at the bottom of the screen (Figure 5-49 and Figure 5-50).

Figure 5-49 Align Zone 1 - Program Zone

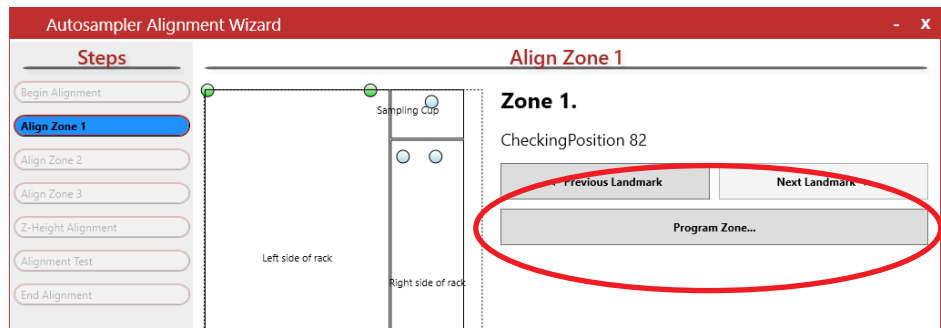
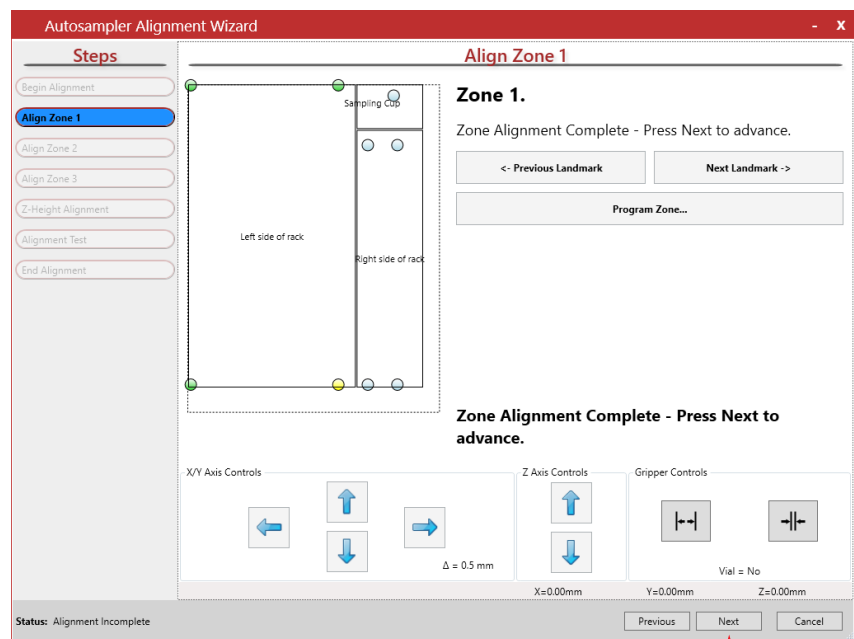

Figure 5-50 Align Zone 1 Complete - Select Next to Continue







**NOTE**

Selecting the Close Box or the Cancel Button during the alignment procedure will display the warning in Figure 5-51. While x and y correction factors for one (or more zones) have been saved, the z-height value has not been defined for the autosampler realignment, and the autosampler will not function properly. It is possible to exit and re-enter the wizard and use the Zone Buttons or Z-Height Alignment Button to advance through the alignment process and complete the necessary alignments.

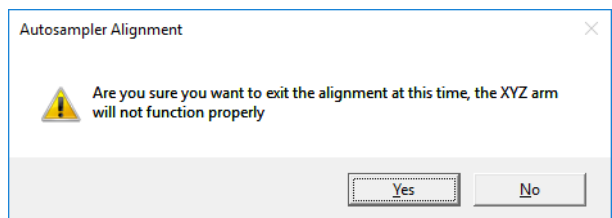
Figure 5-51 Cancel Alignment Notification



11. Repeat the alignment procedure for Zone 2. Once the zone is programmed, select the NEXT BUTTON to continue to Zone 3. Zone 3 is the sample vial cup and only has one alignment landmark (the Zone 3 landmark is also the test point). Once Zone 3 has been programmed, continue to the z-height alignment.
12. To perform the z-height alignment, remove the alignment probe from the gripper by selecting the OPEN GRIPPER BUTTON , then remove the alignment probe.

**Also be sure to remove the alignment target from the sample vial cup.** Place a 40 mL vial with cap and septa in position 1 of the autosampler vial rack as shown in Figure 5-53. Select the START ALIGNMENT BUTTON to begin. The autosampler will move the gripper over position 1 and slowly lower it onto the vial. Once it detects the vial, it will raise the gripper all the way up and then back down on the vial.

Figure 5-52 Z-Height Alignment

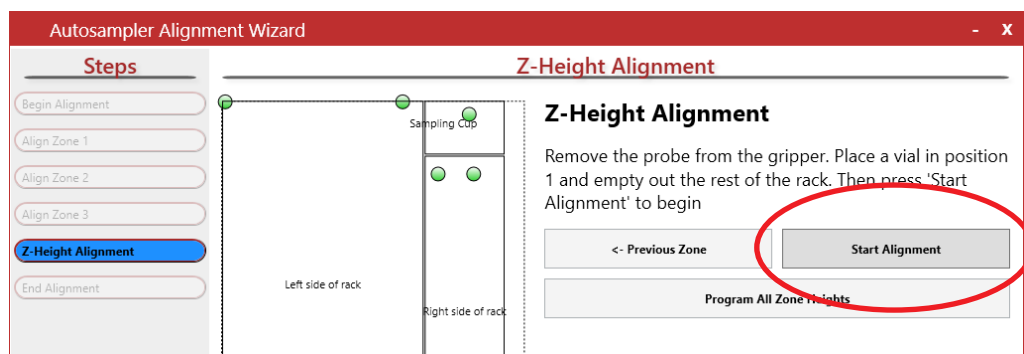
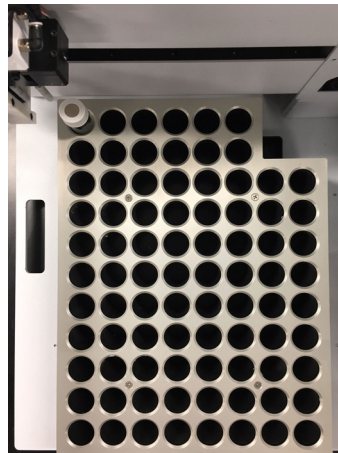
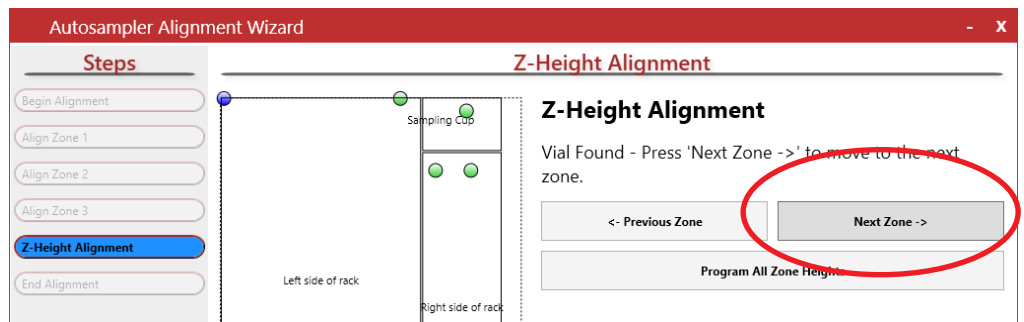

Figure 5-53 Vial in Position 1



- Once the vial height has been found for position 1 (Zone 1), the wizard will state "Vial Found". Select the NEXT ZONE BUTTON. **The wizard will then close the gripper around the vial, pick it up, and place it into Zone 2.** The wizard will then find the z-height alignment for that zone. Once the wizard states "Vial Found" for Zone 2, select the NEXT ZONE BUTTON again. The wizard will then move the vial to the sample vial cup and locate the z-height for Zone 3.

Figure 5-54 Z-Height Alignment - Vial Found



- When the z-height alignment has been found for Zone 3, select the PROGRAM ALL ZONE HEIGHTS BUTTON to save the z-height correction factors to the autosampler. Allow the wizard time to write the new parameters to the autosampler.

Figure 5-55 Z-Height Alignment Complete for All Zones - Program All Zone Heights

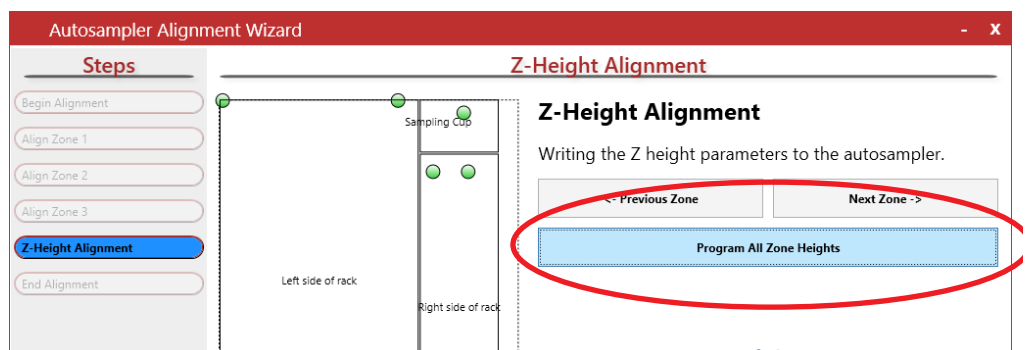

- Once the wizard completes the z-height programming, click the NEXT BUTTON.

Figure 5-56 Z-Height Alignment Complete - Select Next Button

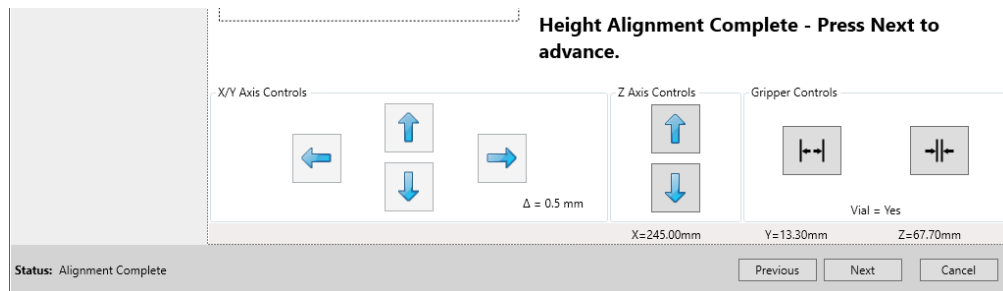

- The wizard will display the ALIGNMENT TEST SCREEN. This page is used to test the accuracy of the alignment by moving a vial through all three zones. Allow the wizard time to enable the alignment before proceeding.

Figure 5-57 Alignment Test Screen

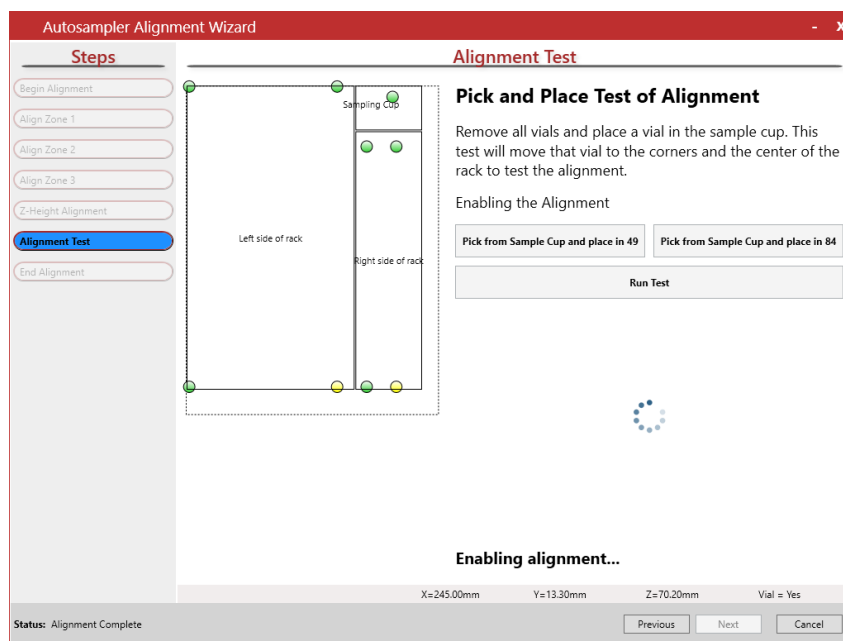

- Place a 40 mL vial with cap and septa in the sample vial cup. All other positions on the autosampler vial rack should be empty. Begin the test by selecting the RUN TEST BUTTON. The test will pick and place the vial to and from the following positions: Sample Cup, Position 84, Position 1, Position 77, Position 20 and Position 49. To only test specific zones select the buttons above the RUN TEST BUTTON.

Figure 5-58 Begin Alignment Test

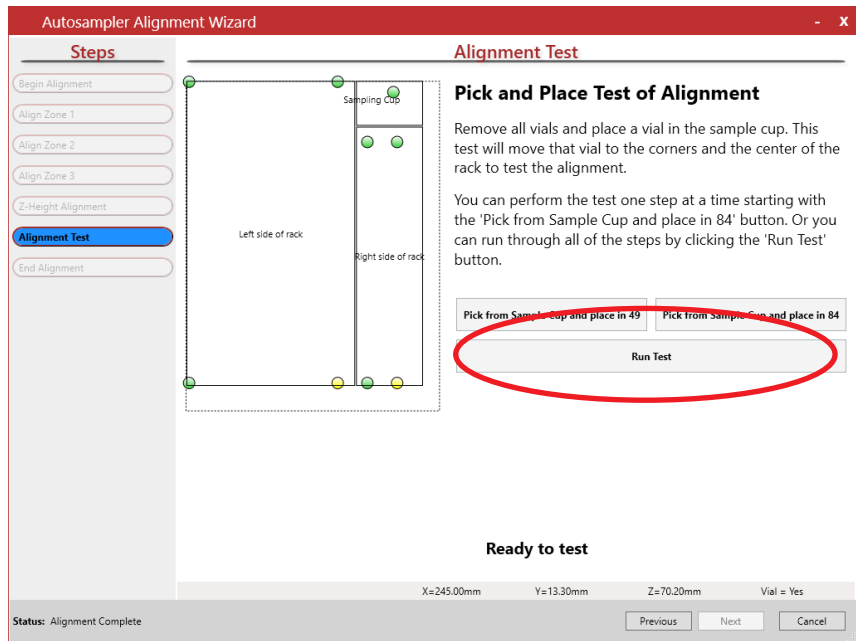

If an error occurs during the test, note the zone where the error occurred and use the Previous Button to re-align that zone. Once the zone is realigned, perform the Z-Height Alignment.

18. Click on the FINISH BUTTON to exit the AUTOSAMPLER ALIGNMENT WIZARD.

Figure 5-59 Alignment Complete

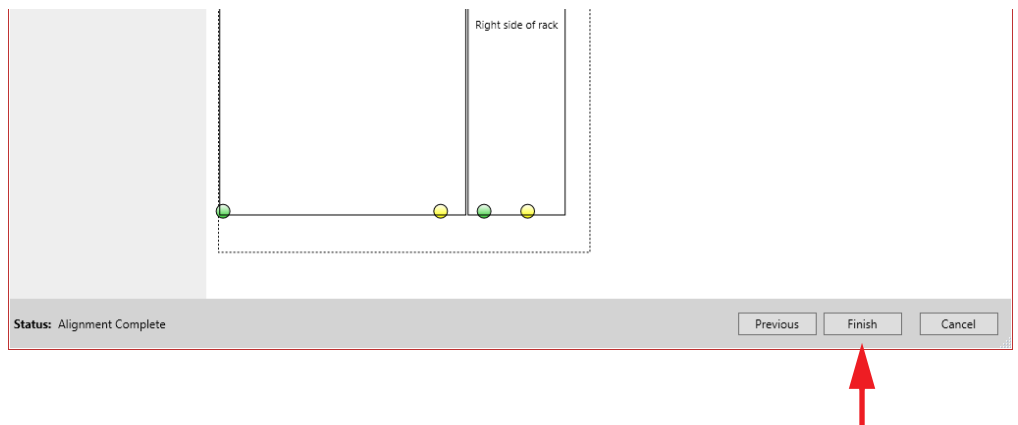

## 5.17 Syringe Initialization

Initializing the syringe resets the syringe starting position to its factory default reference point.



**Warning! The instrument must be powered and the syringe drive moving for the initialization procedure. Do not place hands and/or other appendages in the path of travel of the syringe drive.**

1. Select the TOOLS BUTTON, then select the CHANGE SYRINGE WIZARD BUTTON.
2. Once the wizard opens, select NEXT, then choose NO, I JUST WANT TO REINITIALIZE THE EXISTING SYRINGE. The wizard will automatically initialize the syringe.



### NOTE

The Syringe can also be initialized from the Pumper Diagnostics Screen. Select Tools Screen>Pumper CMD Button.

## 5.18 Syringe Replacement



**Warning! The instrument must be powered and the syringe drive moving for the syringe change procedure. Do not place hands and/or other appendages in the path of travel of the syringe drive.**

1. Select the TOOLS BUTTON to display the TOOLS SCREEN. Select the CHANGE SYRINGE WIZARD BUTTON to display the wizard.
2. Follow the wizard's prompts through the syringe replacement procedure. Once the syringe has been replaced, the wizard will then initialize the syringe.

## 5.19 Power Entry Module (PEM) Fuse Replacement



### NOTE

This section explains the procedure for replacing blown fuses. If a fuse has blown, the root cause of the blown fuse should be determined before re-powering the instrument. If you require assistance, contact Teledyne Tekmar Customer Support using information in Section 5.26 "Technical Assistance".

The PEM requires two IEC 5 x 20 mm fuses. To replace the fuses, follow the steps below. Fuses according to electrical standard are shown Table 5-9 "Atomx XYZ Fuse Ratings (2 IEC 5 x 20 mm Fuses)".

Figure 5-60 Atomx XYZ Power Entry Module (PEM)



**Warning! To avoid electrical shock turn OFF and unplug the Atomx XYZ before servicing.**

1. Power off the Atomx XYZ and remove the AC power cable from the back of the unit.
2. Open the hinged fuse module cover by inserting a small flat-head screwdriver at the top, and then pulling the cover down.

Figure 5-61 PEM Fuse Module Cover Open (Removed for Clarity)

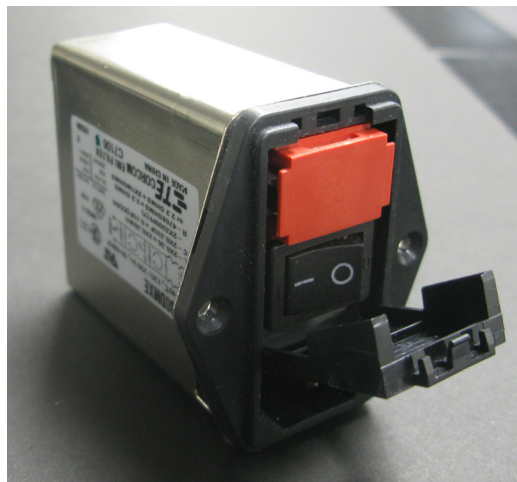

3. Remove the fuse module from the PEM.

Figure 5-62 Fuse Module Removed

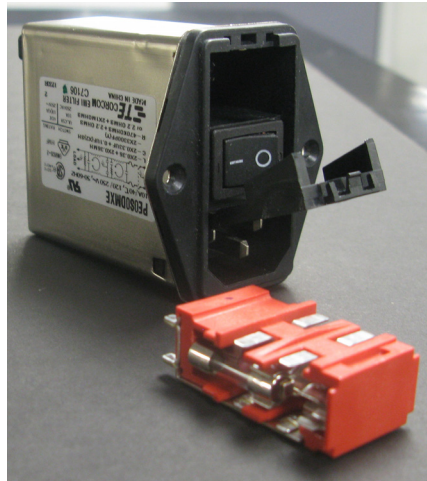

4. Remove the blown fuse(s).
5. Install fuses by pressing them into the fuse module. The correct fuse ratings and specifications are listed on the back of the instrument below the PEM as well as in Table 5-9 "Atomx XYZ Fuse Ratings (2 IEC 5 x 20 mm Fuses)". Fuses should be installed toward the rear of the module (toward the electrical contacts).

 **DANGER**

**The fuses are rated 5A for 230V and 10A for 115V. Only replace fuses with those of the same type and rating.**

Table 5-9 Atomx XYZ Fuse Ratings (2 IEC 5 x 20 mm Fuses)		
Electrical Configuration	Rating	Description
100VAC Operation	T 10.0A – 250v	Time Delay Fuse
115VAC Operation	T 10.0A – 250v	Time Delay Fuse
230VAC Operation	T 5.0A – 250v	Time Delay Fuse

Figure 5-63 Fuse Orientation in Fuse Module

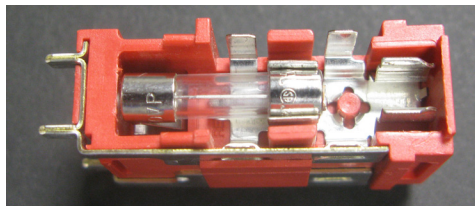

6. Push the fuse module back into the PEM until fully seated. Close the cover over the fuse module.
7. Connect the AC power cord and turn the unit ON.
8. Start the Atomx XYZ TekLink software, if necessary.



## 5.20 Multi-Channel Temperature Control Board Fuse Replacement

### Tools Required

- Phillips-head screwdriver
- Insulated Flat-head screwdriver
- Needle-Nose Pliers (For Heater Output Fuses Only)

### Procedure



**Warning!** To avoid electrical shock turn OFF and unplug the Atomx XYZ before servicing.

### 5.20.1 Main Fuse

1. Power off the Atomx XYZ and remove the AC power cable from the back of the unit. Remove the right access panel, and locate the Temperature Control Board.

Figure 5-64 Multi-Channel Temperature Control Board

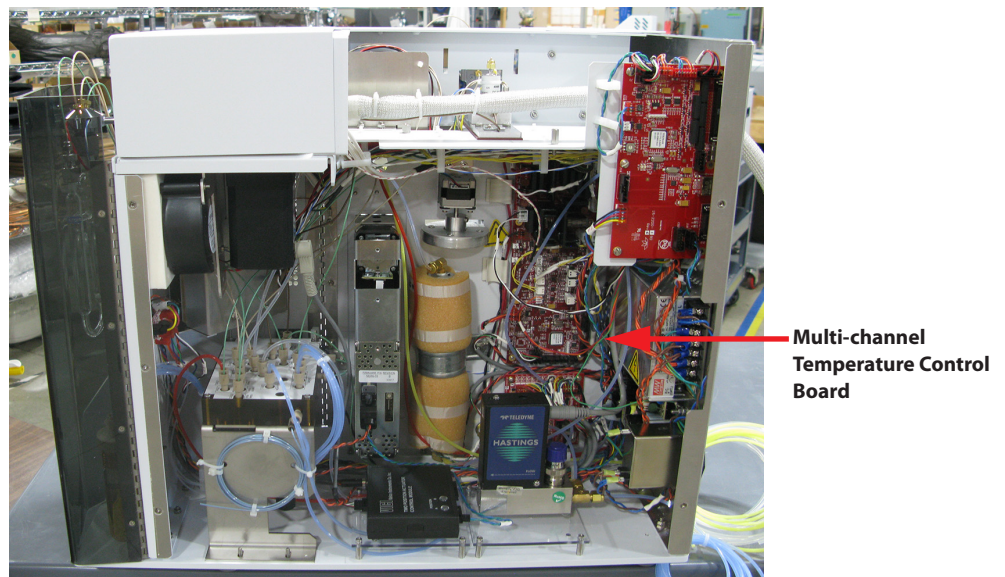

2. Using a properly insulated flathead screwdriver, pry the plastic cover off of the main fuse compartment.
3. Carefully pry the fuse at location “F\_AC” from the fuse compartment.

Figure 5-65 Multi-Channel Temperature Control Board Diagram - Main Fuse

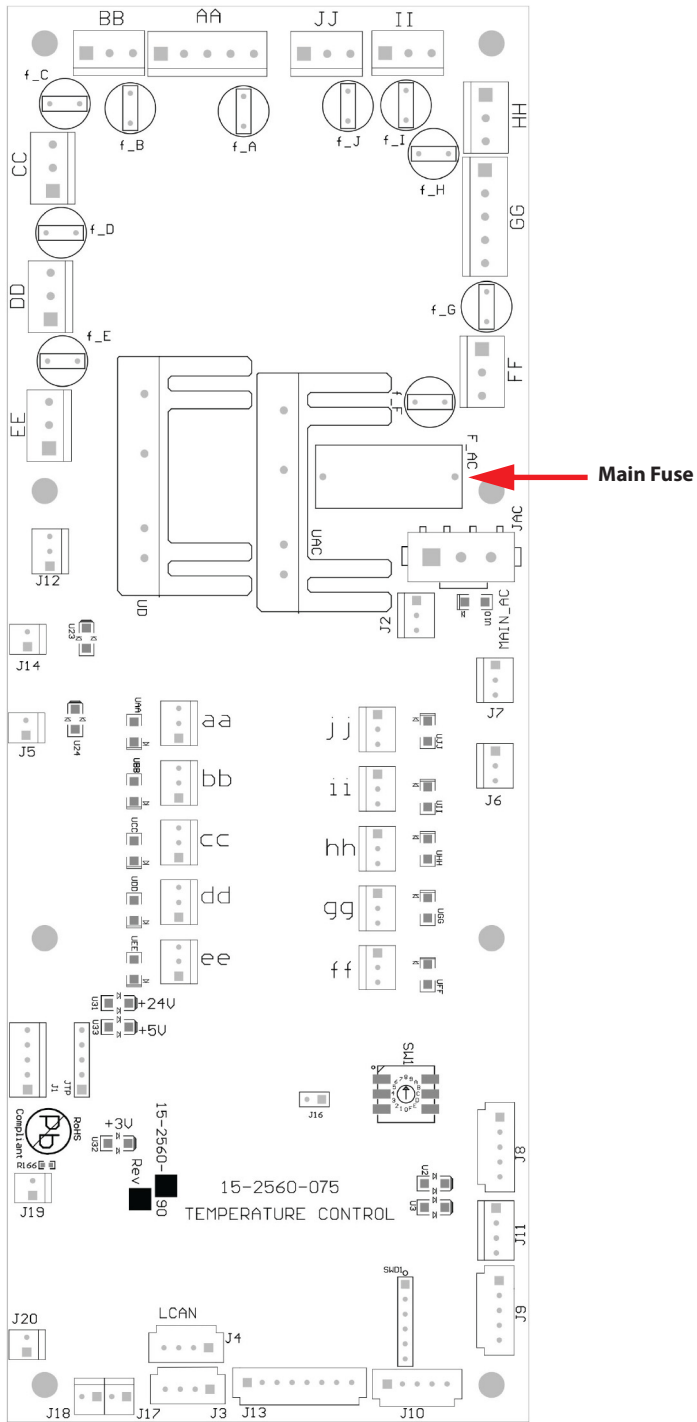

- Carefully insert a new fuse, rated according to Table 5-10 "Main Fuse", in the fuse compartment.

Table 5-10 Main Fuse		
Main AC Inlet	Fuse Location	Fuse Rating
J_AC	F_AC	10 Amps



**Do not use a fuse of any other rating.**

- Replace the plastic cover.
- Reinstall the right access panel.
- Connect the AC power cord and turn the unit ON.
- Start the Atomx XYZ TekLink software, if necessary.

### 5.20.2 Heater Output Fuses

- Power off the Atomx XYZ and remove the AC power cable from the back of the unit. Remove the right access panel, and locate the Temperature Control Board.

Figure 5-66 Multi-Channel Temperature Control Board

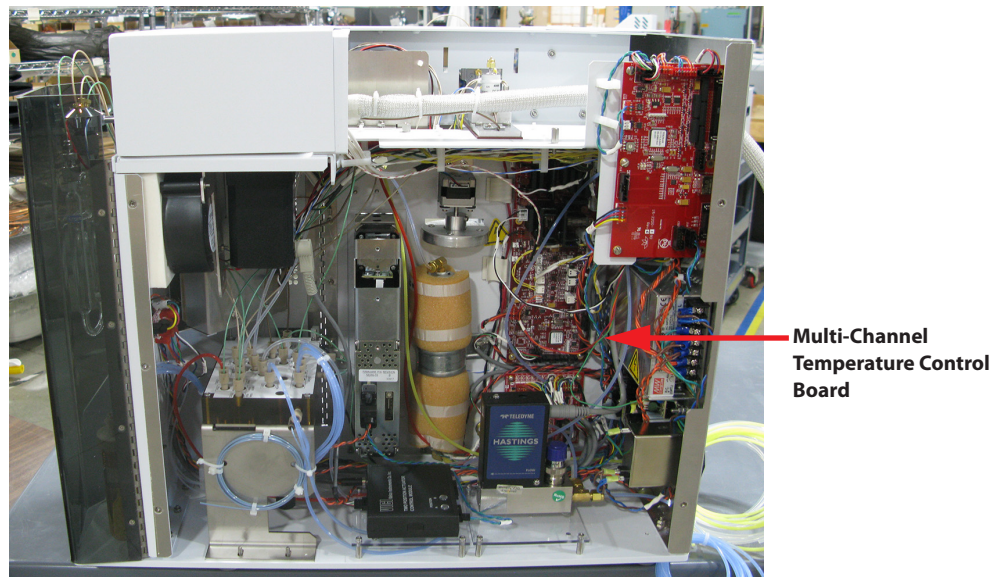

- Refer to Figure 5-67 to locate the appropriate heater output fuse(s). Heater output fuses are cylinder shaped fuses located adjacent to each heated zone at the top of the board. Heated zones are identified on the board (AA, JJ, etc.) The fuse that corresponds to each zone will have the same letter identifier prefixed by the letter "F". Pull the appropriate 2-prong fuse(s) out.

Figure 5-67 Multi-Channel Temperature Control Board  
Diagram - Heater Output Fuses

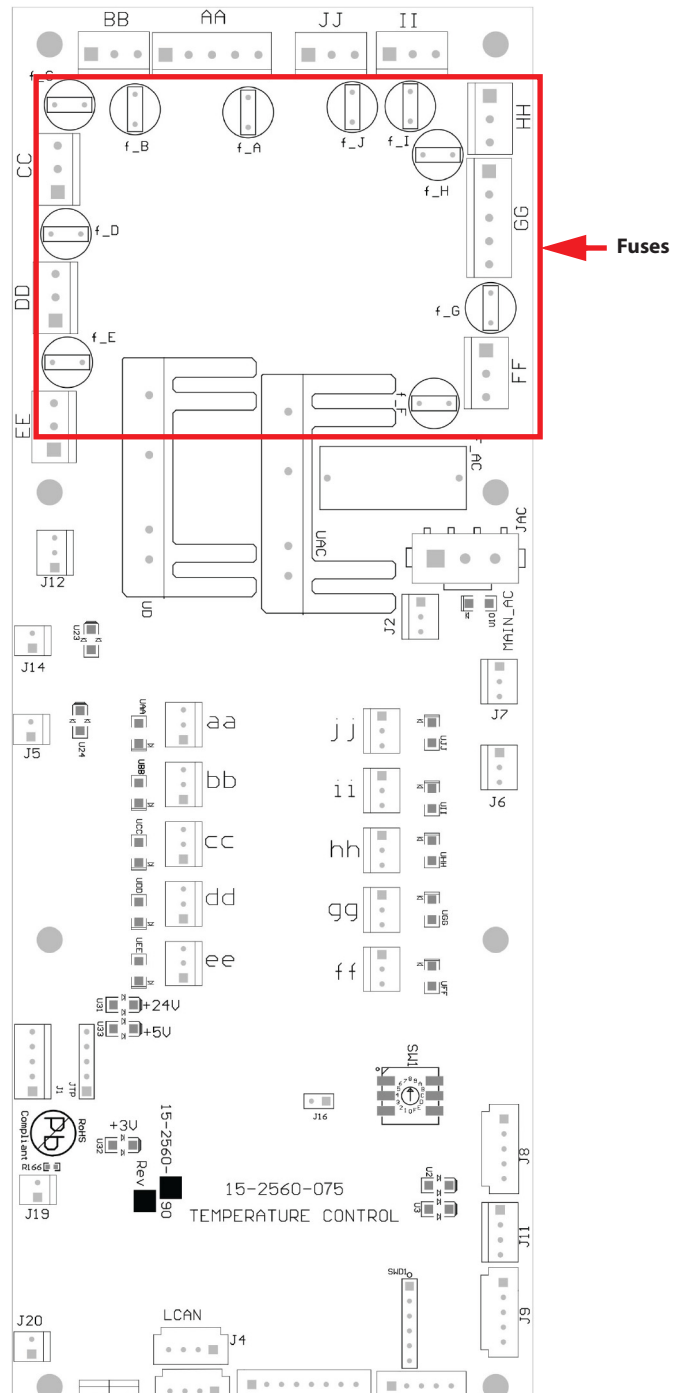

3. Remove the appropriate fuse by grasping it with a needle-nose pliers and pulling straight out.

- Carefully insert a new fuse, rated according to Table 5-11 "Heater Output Fuses", into the board ensuring both pins of the fuse are aligned with the receiving holes.

<b>Table 5-11 Heater Output Fuses</b>			
<b>Zone Description</b>	<b>Heated Zone Location Designator</b>	<b>Fuse Location Designator</b>	<b>Fuse Rating</b>
Transfer Line	AA	f_A	3.1 Amps
Oven	BB	f_B	2 Amps
Mount	CC	f_C	2 Amps
Trap	DD	f_D	5 Amps
Sample Cup	EE	f_E	2 Amps
Moisture Control System (MCS)	FF	f_F	2 Amps
Spurge Vessel	GG	f_G	2 Amps
Soil Valve	HH	f_H	2 Amps
Water Reservoir	II	f_I	2 Amps



**Do not use a fuse of any other rating.**

- Reinstall the right access panel.
- Connect the AC power cord and turn the unit ON.
- Start the Atomx XYZ TekLink software, if necessary.

## 5.21 Upgrade Firmware

First download the firmware and then install it according to the directions below.

### 5.21.1 Download Firmware

- Click this hyperlink: Software Downloads (<http://www.teledynetekmar.com/Resource-Center/software-firmware-updates>) or go to the Software/Firmware downloads page at [www.teledynetekmar.com](http://www.teledynetekmar.com)
- Under VOC Firmware and Software, find the appropriate firmware update.
- Follow all prompts to download the new firmware.

## 5.21.2 Upgrade Board Firmware

1. Navigate to TOOLS>UPGRADE FIRMWARE.

Figure 5-68 Upgrade Firmware Dialog

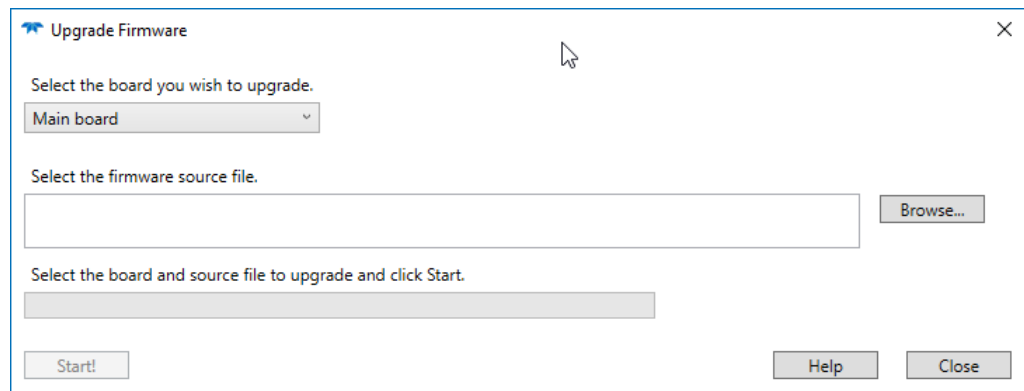

2. In the UPGRADE FIRMWARE DIALOG, select the board to upgrade from the BOARD DROP-DOWN MENU.
3. Using the BROWSE BUTTON, navigate to the firmware source file that was downloaded.
4. Select the START BUTTON and follow all installation prompts.

## 5.22 Upgrade Atomx XYZ TekLink Software

1. Click this hyperlink: Software Downloads (<http://www.teledynetekmar.com/Resource-Center/software-firmware-updates>) or go to the software downloads page at [www.teledynetekmar.com](http://www.teledynetekmar.com)
2. Under VOC Firmware and Software, find the appropriate software update.
3. Follow all prompts to download the new software.
4. Select the downloaded software executable file to start the software upgrade, then follow all installation prompts.

## 5.23 Troubleshooting

### 5.23.1 Benchmark Test

The BENCHMARK SELF TEST is a troubleshooting tool that tests the components and software routines (heaters, LEDs, continuity of inputs and outputs on the CPU communication board, etc.) to ensure that the system is in working order. If any sequence of the benchmark test fails, the failure should be addressed before analysis of samples is attempted.

Some tests will be completed automatically, while others will require user response. The benchmark test may be stopped at any time by clicking the STOP BENCHMARK BUTTON in the BENCHMARK DIALOG. Advance to a specific section of the test by selecting the item in the TEST SEQUENCE WINDOW.



Make sure to give the Atomx XYZ the necessary time to complete the task.

The results of the benchmark test can be printed at the completion of the test and are automatically saved in the INSTRUMENT HISTORY LOG using the name entered at the beginning of the test.

1. From the TOOLS SCREEN select the BENCHMARK BUTTON to start the benchmark function.
2. Name the benchmark test, then select the START BENCHMARK BUTTON.

Figure 5-69 Benchmark Test

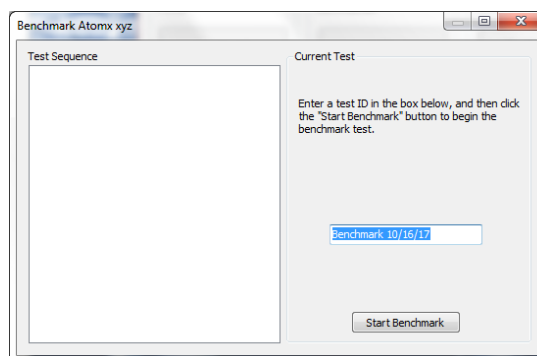

3. Once started, the TEST SEQUENCE WINDOW will display the actions of the benchmark test. The CURRENT TEST section of the dialog will explain the item being tested and prompt the user to respond. The INSTRUMENT STATUS PANEL will also indicate that a benchmark test is being conducted.

Figure 5-70 Benchmark Test Prompt

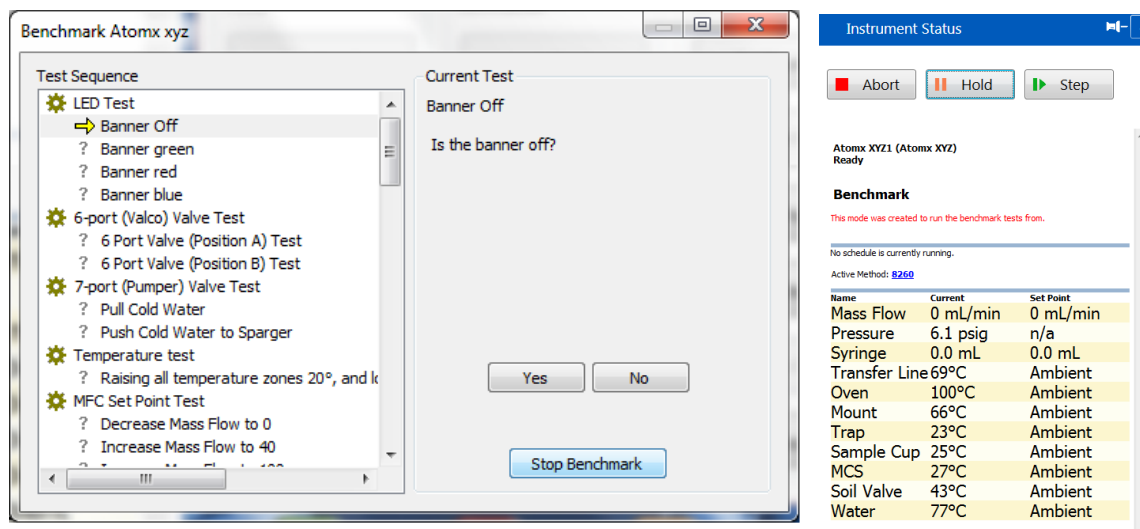

4. As the benchmark test is conducted, Atomx XYZ TekLink will prompt the user for responses. Read the prompt and respond accordingly using the buttons in the BENCHMARK TEST WINDOW.
5. Prior to completion of the test, Atomx XYZ TekLink will prompt if the benchmark test report should be printed. Once completed, results of the test are saved in the INSTRUMENT HISTORY LOG as a BENCHMARK REPORT. To access a saved benchmark test, go to TOOLS>VIEW HISTORY LOG>INSTRUMENT HISTORY TAB. Select the RESTRICT BY EVENT TYPE FILTER CHECK BOX, then select BENCHMARK REPORT from the selections.



### 5.23.2 No Power Flow Chart

**NOTE**

Refer to Section 5.19 "Power Entry Module (PEM) Fuse Replacement" for information on accessing the PEM fuses.

Figure 5-71 No Power Flow Chart

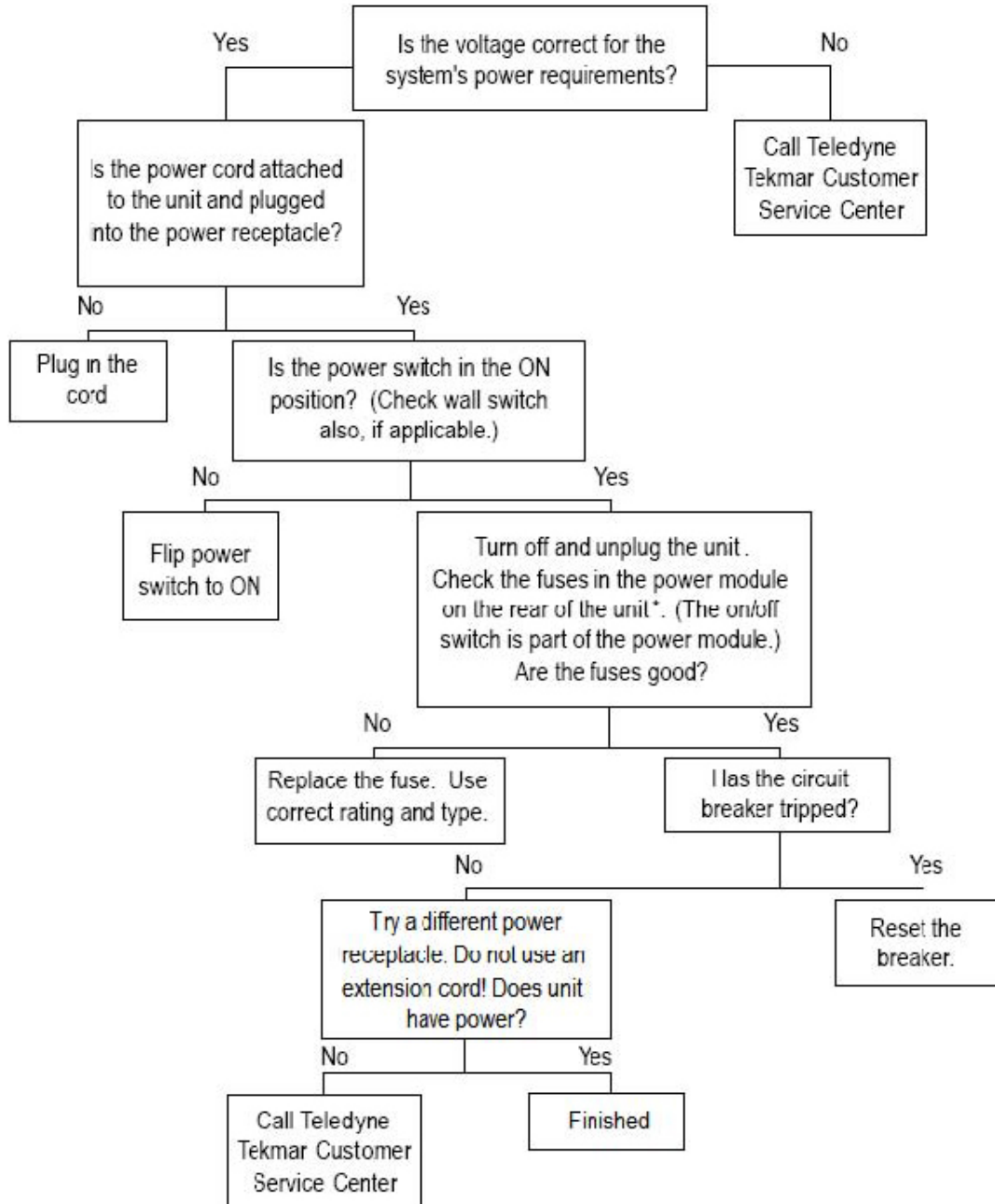

### 5.23.3 No Response Flow Chart

Figure 5-72 No Response Flow Chart

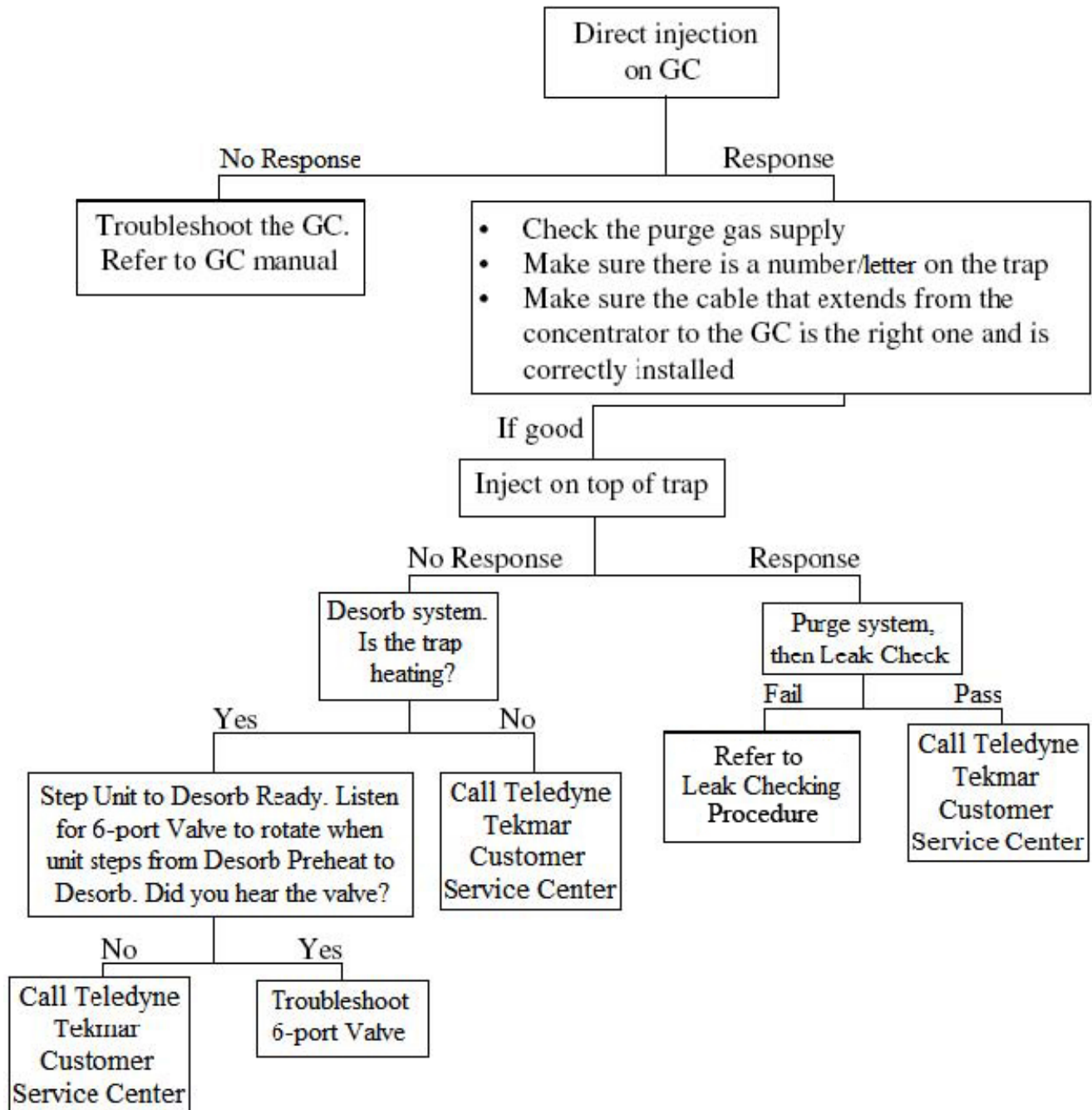

### 5.23.4 Low Response Flow Chart

Figure 5-73 Low Response Flow Chart

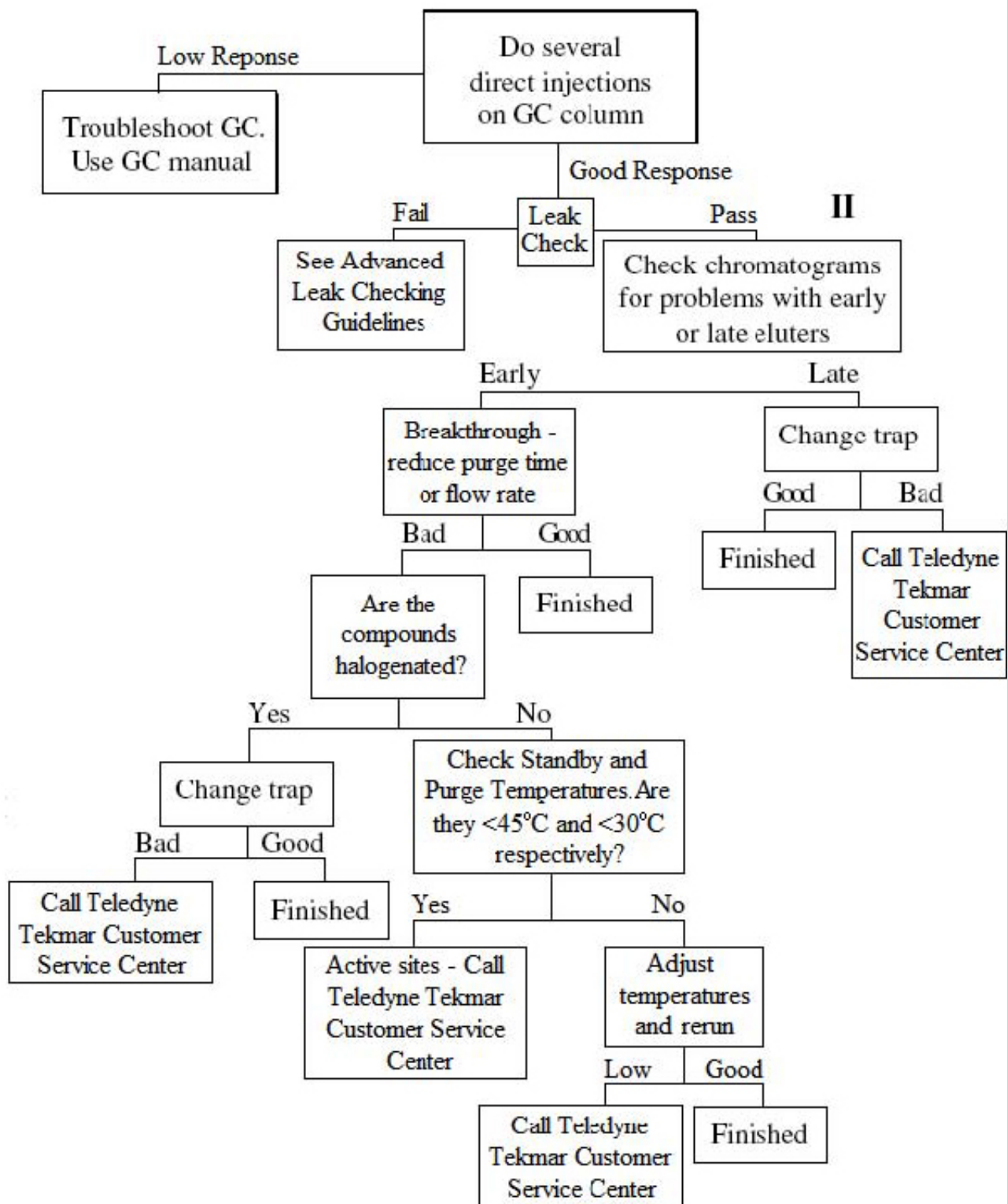

### 5.23.5 Carryover Contamination Flow Chart

Figure 5-74 Carryover Contamination Flow Chart

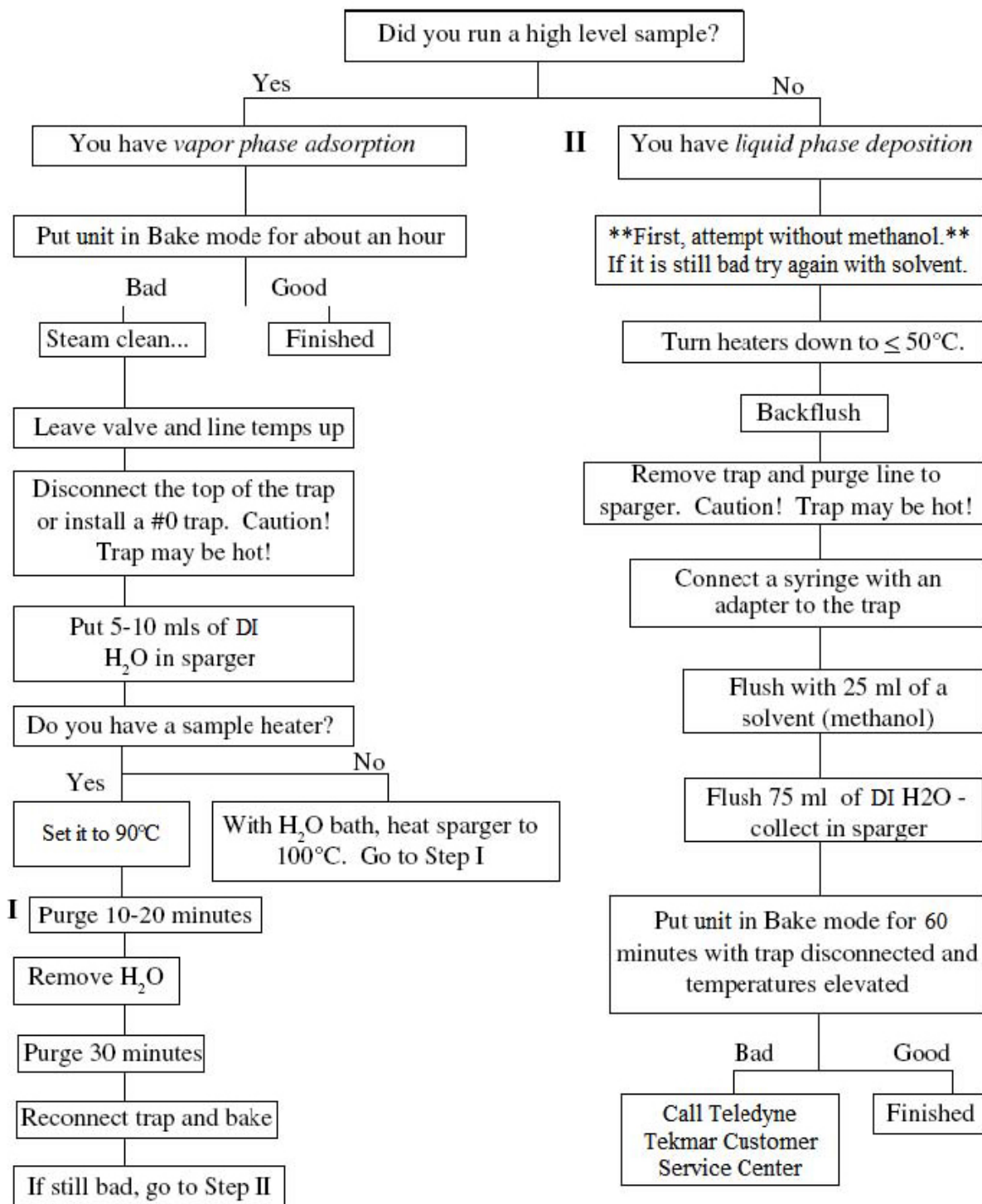

## 5.24 Returning the Atomx XYZ

**Do not** return the Atomx XYZ unless a Teledyne Tekmar Representative authorizes you to do so. A Customer Support Representative may be able to help you solve the problem over the telephone. If the instrument must be returned, the representative can tell you how to prevent damage during shipment. The representative must give you a return authorization number and instructions on how to return the instrument properly.

### 5.24.1 Prepare for Shipment Function

To prepare for shipment, select **TOOLS>PREPARE FOR SHIPMENT BUTTON** and follow the prompts. Also refer to "Prepare for Shipment/Long-Term Shutdown".

## 5.25 Unit and Parts Disposal



Refer to Section P.8.1 "Unit Disposal".

## 5.26 Technical Assistance

If you need assistance solving a problem, follow the steps below:

1. Write down the model name, model number, and serial number of the instrument.
2. Note the type of problem you are having. Write down the conditions under which the problem occurred, the display, mode of operation, activity, or result that indicated the presence of a problem.
3. Have an electronic or paper copy of this manual, and any other pertinent information, accessible from the telephone. Your Customer Support Representative may refer to diagrams or other information contained in this manual.
4. Call Teledyne Tekmar using Section 5.26.1 "Teledyne Tekmar Customer Support".

### 5.26.1 Teledyne Tekmar Customer Support

**U.S. Phone: (800) 874-2004**

**U.S. Email: [tekmarsupport@teledyne.com](mailto:tekmarsupport@teledyne.com)**

**International Phone (Outside the U.S.): Country Code + 1 (513) 229-7000**

**International Email: [Tekmar\\_Intltech@teledyne.com](mailto:Tekmar_Intltech@teledyne.com)**

# Atomx XYZ User Manual

## Appendix A: Diagrams

### A.1 Atomx XYZ Concentrator Electrical Schematic

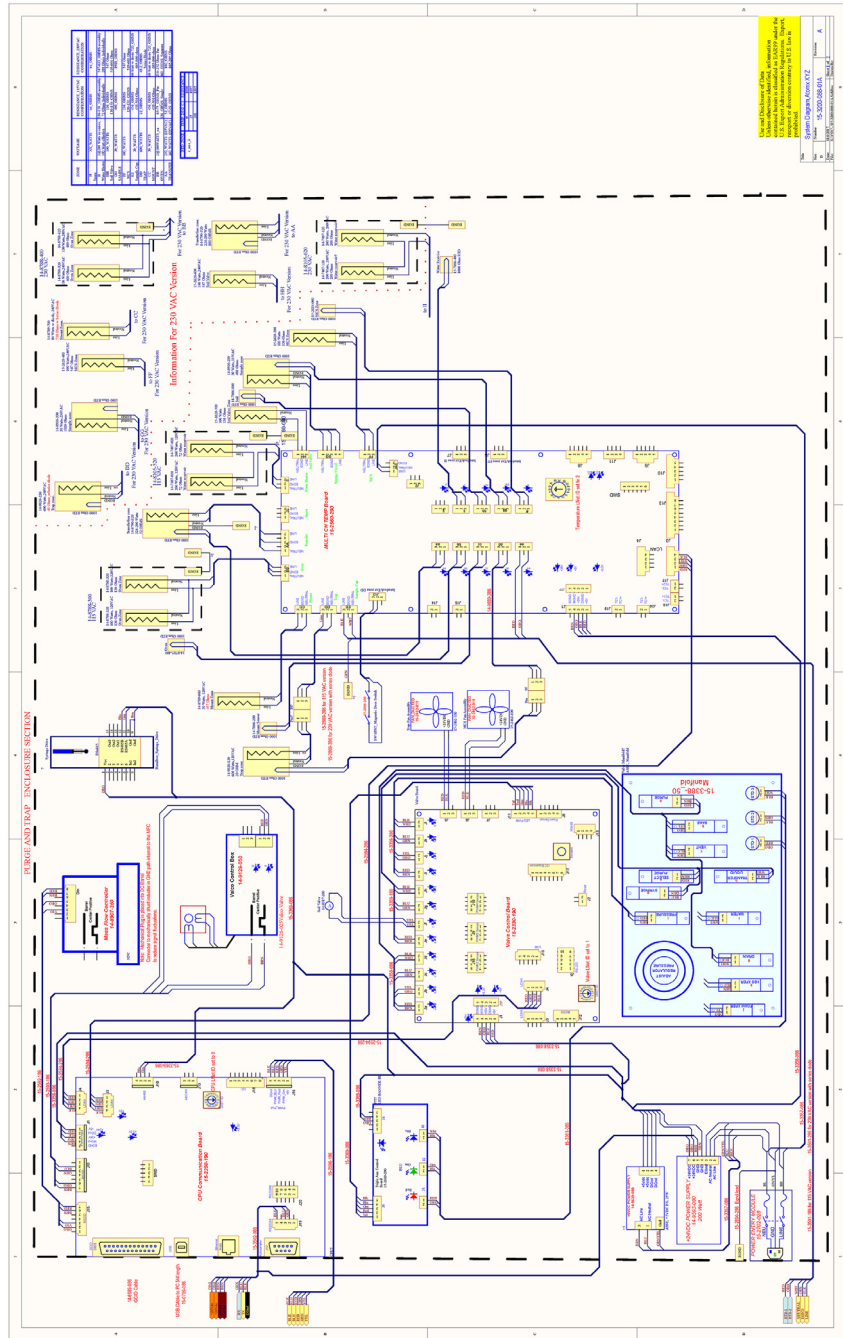

Figure A-1 Atomx XYZ Concentrator Electrical Schematic









ITEM	PART NUMBER	DESCRIPTION	QTY
1	12-0070-016	1/8" BRASS "T"	2
2	14-0241-016	FERRULE, VALCO 1/16" SST	14
3	14-0243-016	NUT, SHORT 1/16 MALE, VALCO	6
4	14-0243-116	NUT, 1/16", SHORT GOLD PLATED	8
5	14-0583-002	TUBING, 1/8 OD, .062 ID, NATURAL FEP	4
6	14-1301-016	FERRULE SET, 1/2 " TEFLON	1
7	14-1356-016	BULKHEAD, 1/4" BRASS	1
8	14-1590-116	NUT, MALE PLUG, 1/16", GOLD PLATED	1
9	14-2261-016	UNION, 1/4-1/16 REDUCING, SST W/TEF FERR.	1
10	14-2337-024	5 mL FRIT SPARGER, 1/2" NECK	1
11	14-2792-016	NUT, PLUG, 1/16" BRASS	1
12	14-4602-116	NUT, 1/8, MALE, VALCO, GOLD PLATED	1
13	14-6934-002	TUBING, PEEK, .062 OD X .040 ID, NATURAL	5
14	14-7038-016	BUSHING, 1/8"	17
15	14-7201-009	WASHER, TEFLON	20
16	14-7630-002	TUBING, 1/8OD, RED, TRANSLUCENT	2
17	14-7633-002	TUBING, 1/8OD, YELLOW, TRANSLUCENT	1
18	14-7634-002	TUBING, 1/8OD, BLUE, TRANSLUCENT	10
19	14-7671-016	FERRULE, SUPER FLANGELESS, 1/16", PEEK	23
20	14-7695-016	NUT, 1/16 " PEEK	23
21	14-8105-_20	HEATER, HOT WATER, 115VAC	1
22	14-8131-054	SPRING, EXTENSION 2.375 LG. X .37 O.D. X .031 THK.	1
23	14-8317-050	VALVE, HIGH TEMP 3 PORT 24VDC	1
24	14-8470-016	PLUG NUT, 1/4-28, TEFZEL, FLAT BOTTOM	1
25	14-8659-016	NUT, 1/8", 1/4-28 THD. P.E.E.K.	17
26	14-8790-_20	TRANSFERLINE HEATER	1
27	14-8907-450	MFC ASSY, 1/8" TEE	1
28	14-8919-016	1/8" TO 1/16" GRAPHITE FERRULE	1
29	14-8927-002	TUBING, 1/16" PEEK GREEN	7
30	14-9024-016	STAINLESS STEEL FRIT, 2 MICRON, .200" OD	1
31	14-9042-016	FERRULE, TFZL W/ SS RING 1/16"	1
32	14-9043-016	NUT SUPER FLANGELESS 1/16" HEADLESS	1
33	14-9126-050	VALCO, VALVE, 6-PORT	1
34	14-9384-002	TUBING, PEEK, BLUE, .010 X 1/16	1
35	14-9453-002	TUBING, .062X.040 INERTIUM W/ ULTRA DEAC	7
36	14-9828-_20	TRAP HEATER ASSEMBLY	1
37	14-9908-403	#9 TRAP	1
38	14-9924-016	BARB FITTING TO 1/4-28	1
39	15-0136-002	TUBING, 1/4" BLUE POLYURETHANE	1
40	15-0155-016	NUT, 1/2 SS SAMPLE MOUNT	1
41	15-0171-016	SAMPLE MOUNT, ASSY	1
42	15-0201-024	VESSEL, 15ml, AMBER-I.S.	5
43	15-0202-079	BUSHING, PEEK W/ VITON O-RING, I.S. VESSEL	5
44	15-0270-052	SYRINGE, 27ml W/SIDE PORT	1
45	15-0272-002	LINE ASSY, IS, W/ MINSTAC CONNECTOR	3
46	15-0278-050	VALVE, CHECK, IN LINE 1/4-28	1
47	15-0285-016	FERRULE, 1/8 VESPEL	1
48	15-2076-016	INSERT, TUBING, BRASS 6MMOD X 4MM ID	3
49	15-2260-016	CONDENSATE TRAP BLOCK, SS 316	1
50	15-2463-016	1/8-1/16" REDUCING BULKHEAD	1
51	15-3198-053	NEEDLE, 3 STAGE	1
52	15-3199-079	CUP, VIAL SAMPLE	1
53	15-3385-050	VALVE, HAMILTON 6-PORT SYRINGE VALVE HVXC 6-5	1
54	15-3388-050	VALVE MANIFOLD ASSY, PARKER 9 POSITION	1
55	15-3481-016	ELBOW FITTING, BRASS, 1/4X1/8	1

## A.4 Atomx XYZ Flow Diagrams

Note: Also refer to Section 5.8.1 "System Leak Check Flow Diagram".

### A.4.1 Atomx XYZ - Basic Flow Diagram

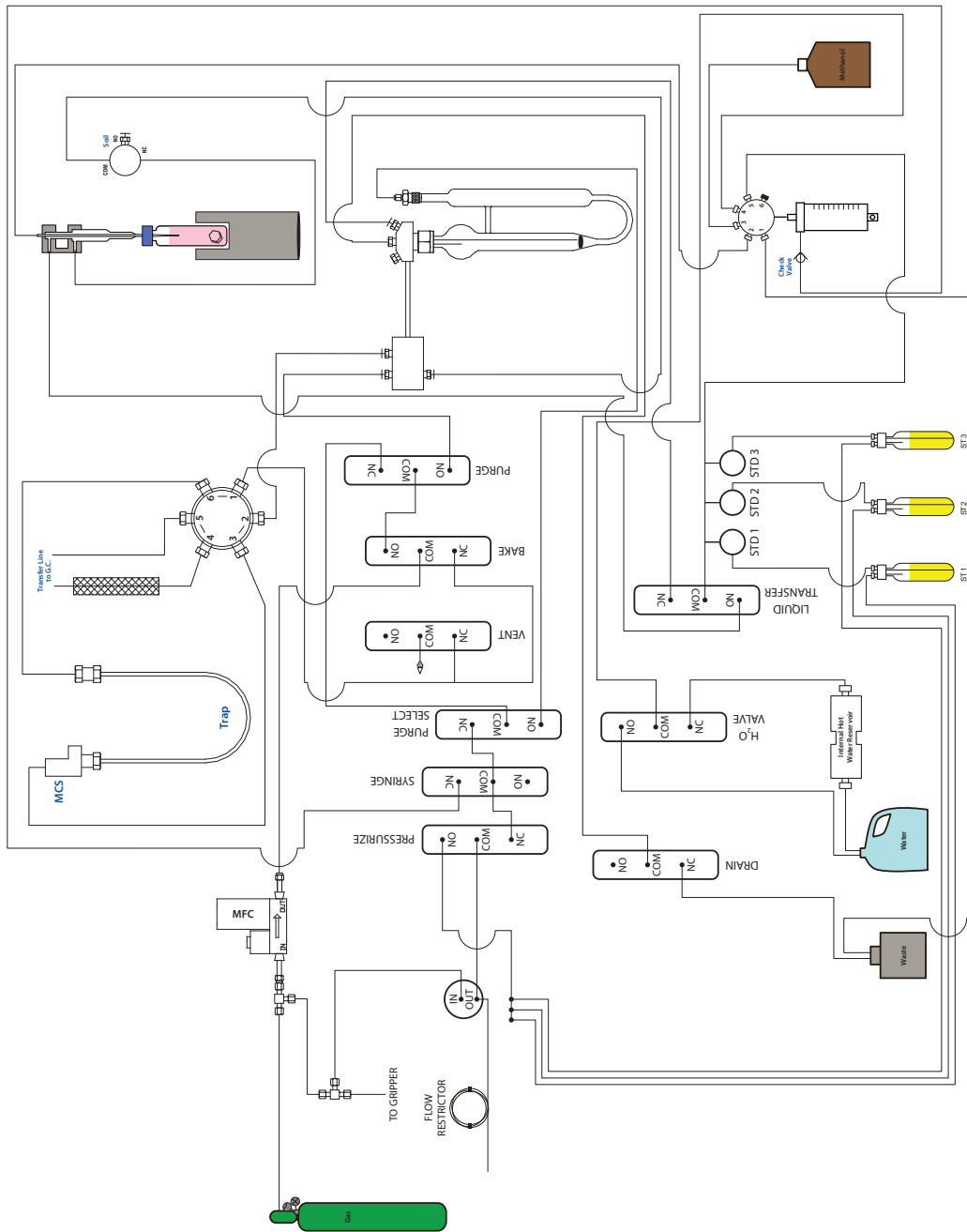

Figure A-4 Atomx XYZ - Basic Flow Diagram

**A.4.2 Atomx XYZ - Waters Flow Diagram - Standby/Purge Ready**

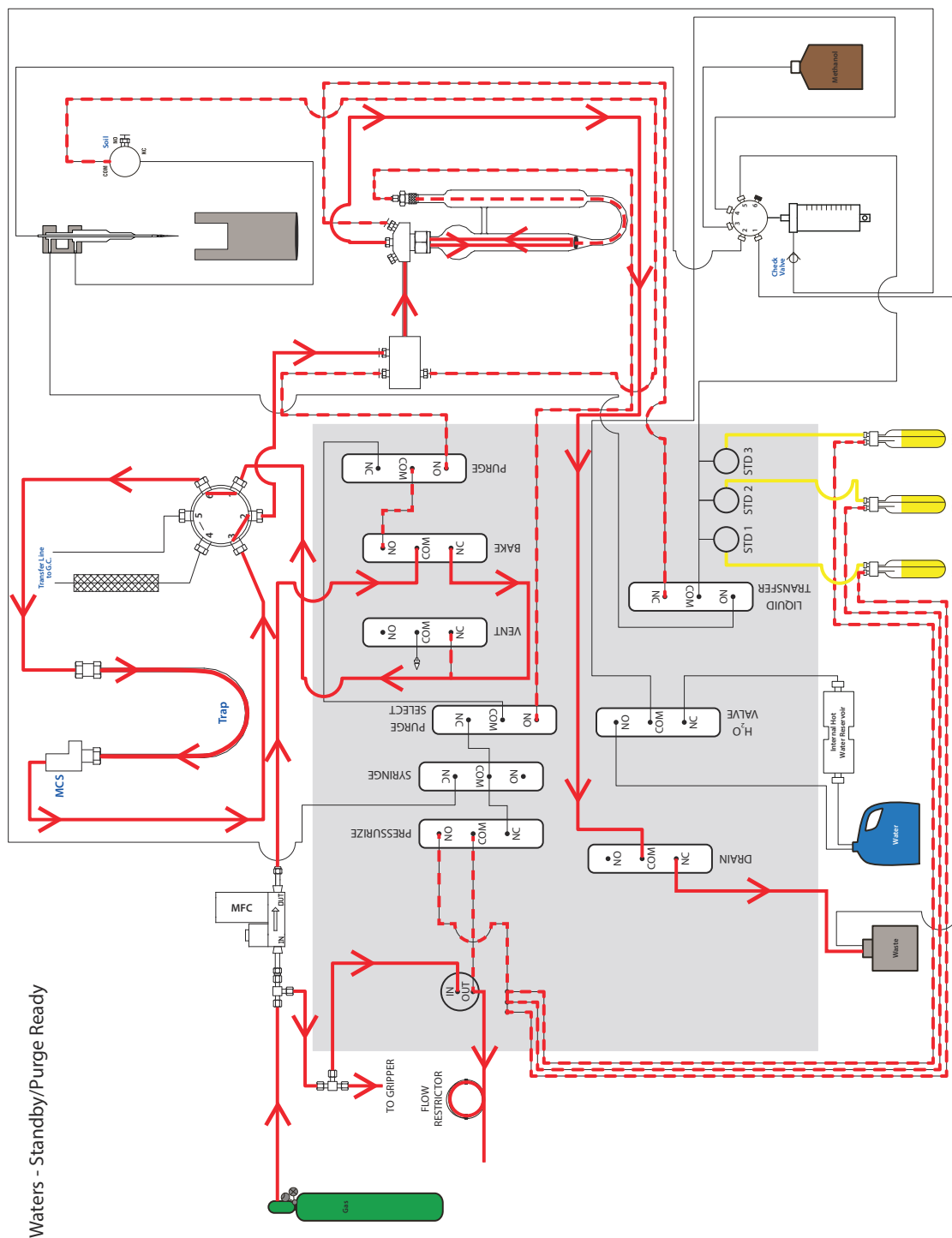

Figure A-5 Atomx XYZ - Waters Flow Diagram - Standby Purge Ready

A.4.3 Atomx XYZ - Waters Flow Diagram - Sample Fill

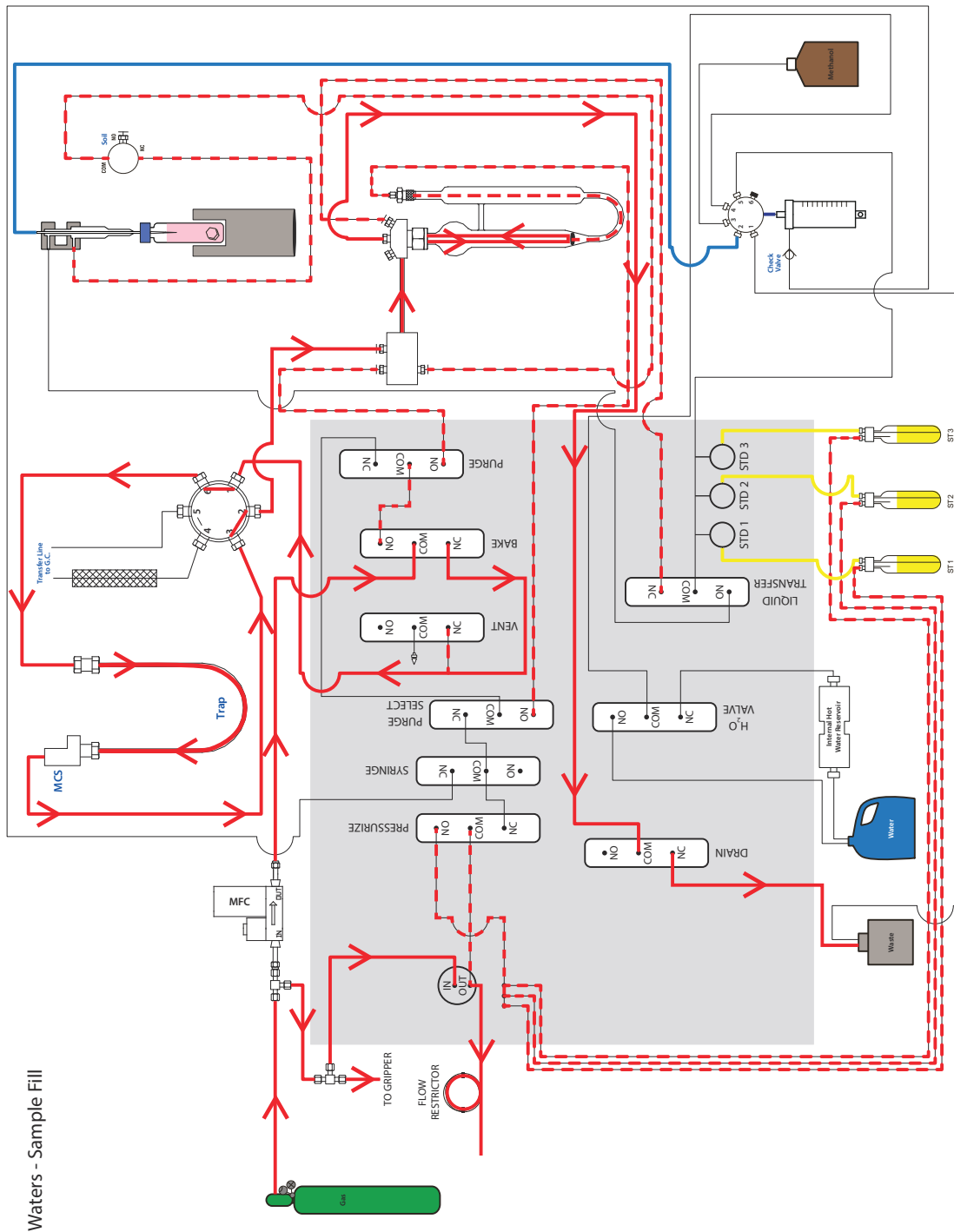

Figure A-6 Atomx XYZ - Waters Flow Diagram - Sample Fill



A.4.5 Atomx XYZ Waters Flow Diagram - Purge

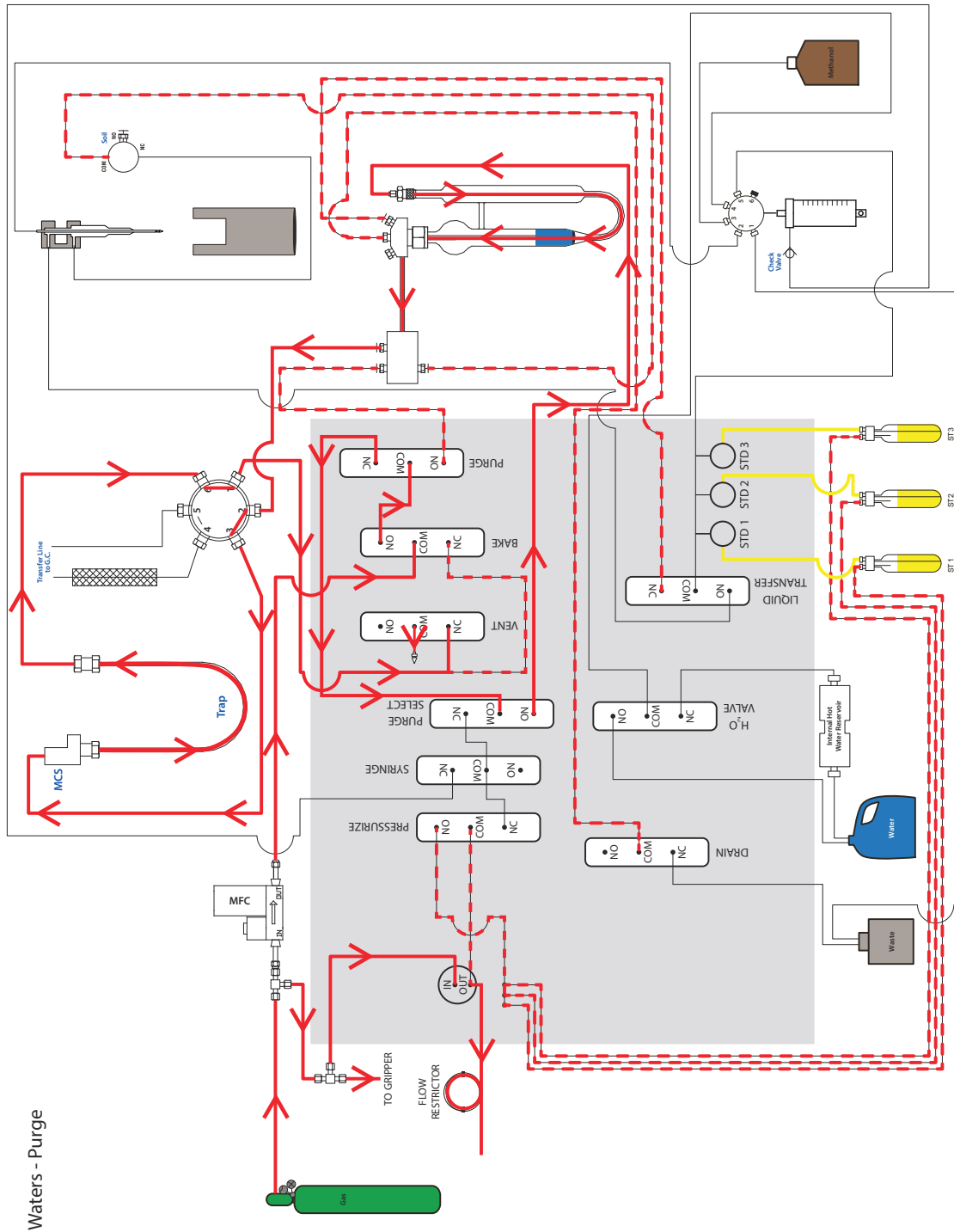

Figure A-8 Atomx XYZ - Waters Flow Diagram - Purge



### A.4.6 Atomx XYZ Waters Flow Diagram - Dry Purge

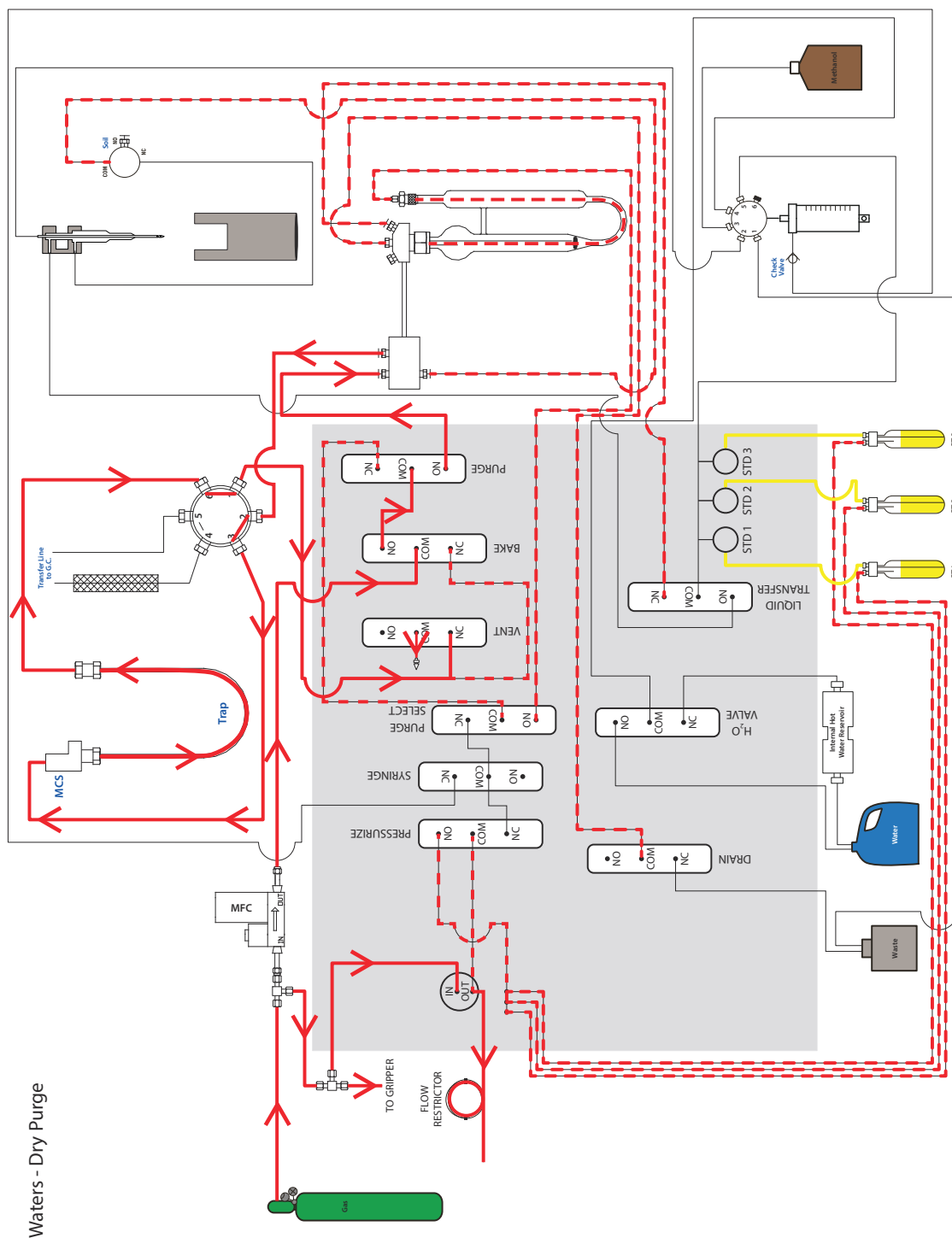

Figure A-9 Atomx XYZ - Waters Flow Diagram - Dry Purge

A.4.7 Atomx XYZ Waters Flow Diagram - Desorb

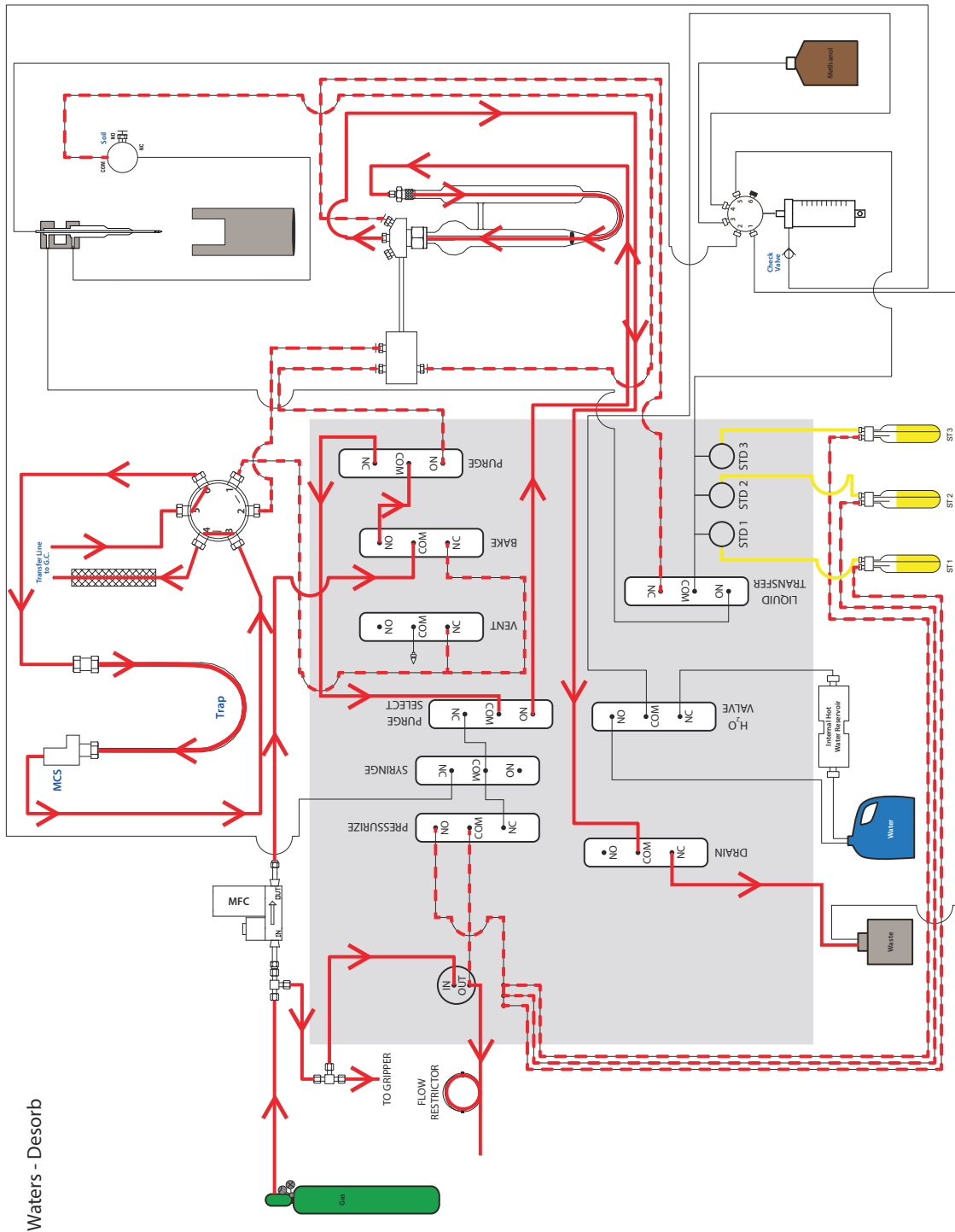

Figure A-10 Atomx XYZ - Waters Flow Diagram - Desorb

**A.4.8 Atomx XYZ Waters Flow Diagram - Bake Rinse Fill**

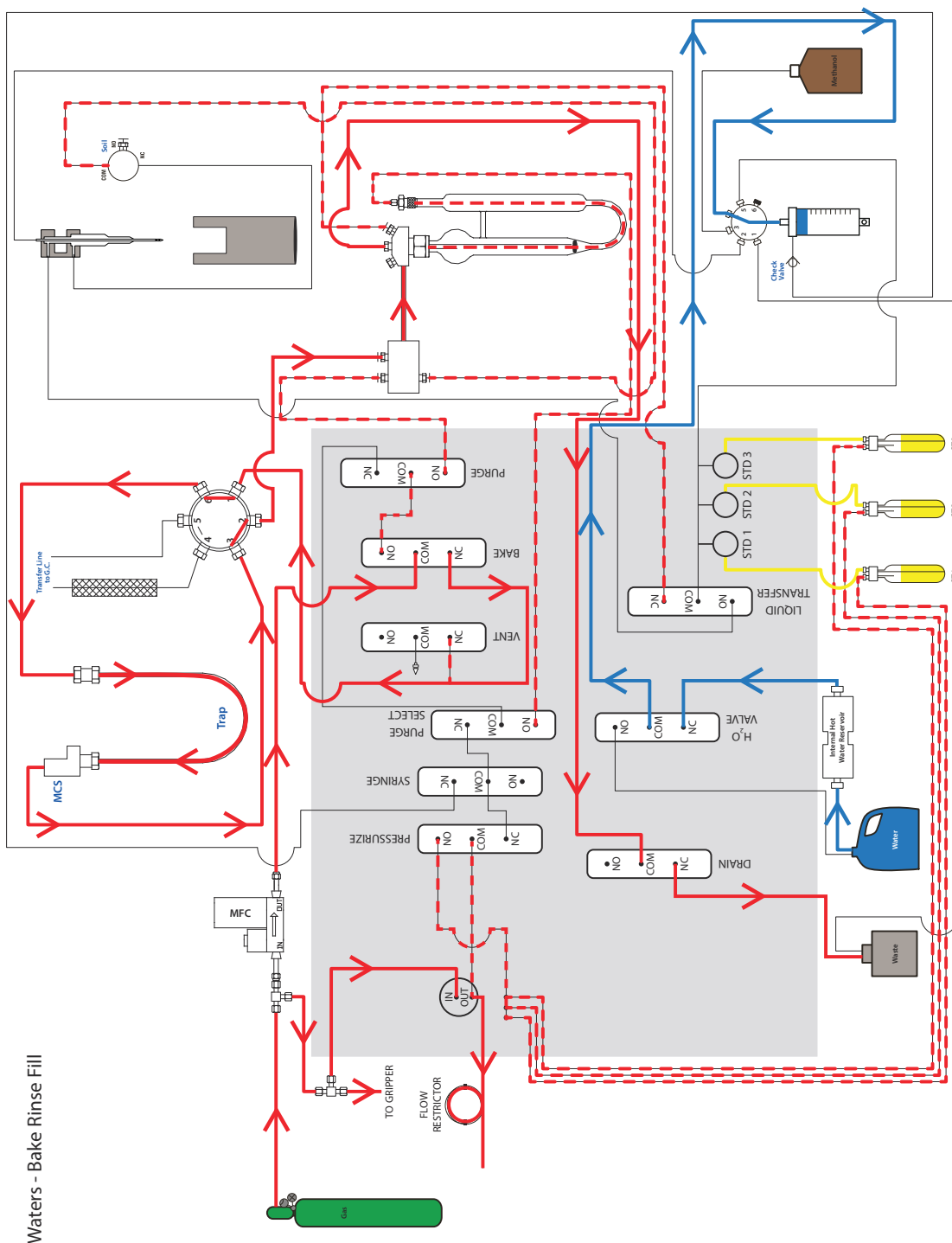

Figure A-11 Atomx XYZ - Waters Flow Diagram - Bake Rinse Fill

A.4.9 Atomx XYZ Waters Flow Diagram - Bake Rinse Transfer

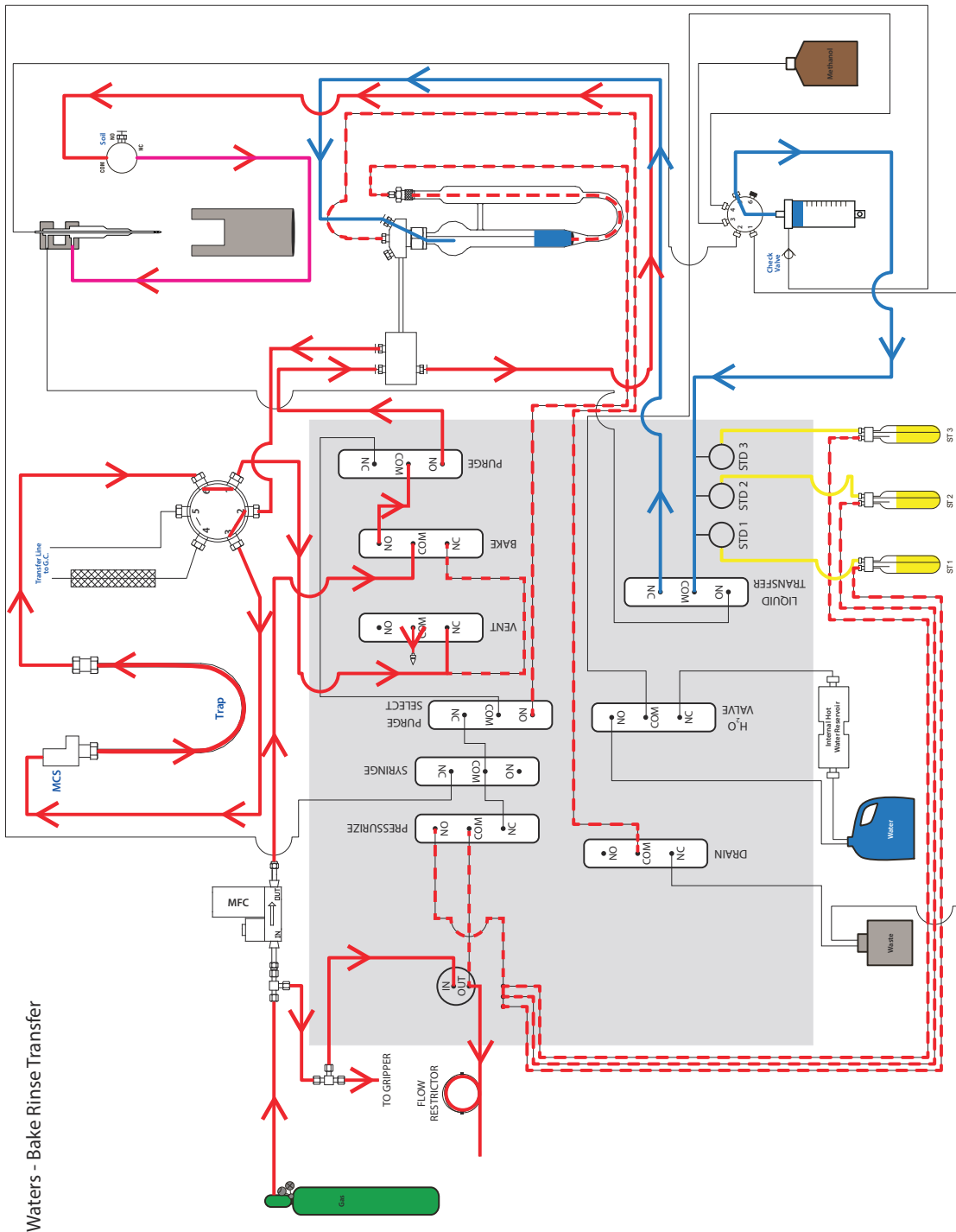

Figure A-12 Atomx XYZ - Waters Flow Diagram - Bake Rinse Transfer

**A.4.10 Atomx XYZ Waters Flow Diagram - Bake Rinse Drain**

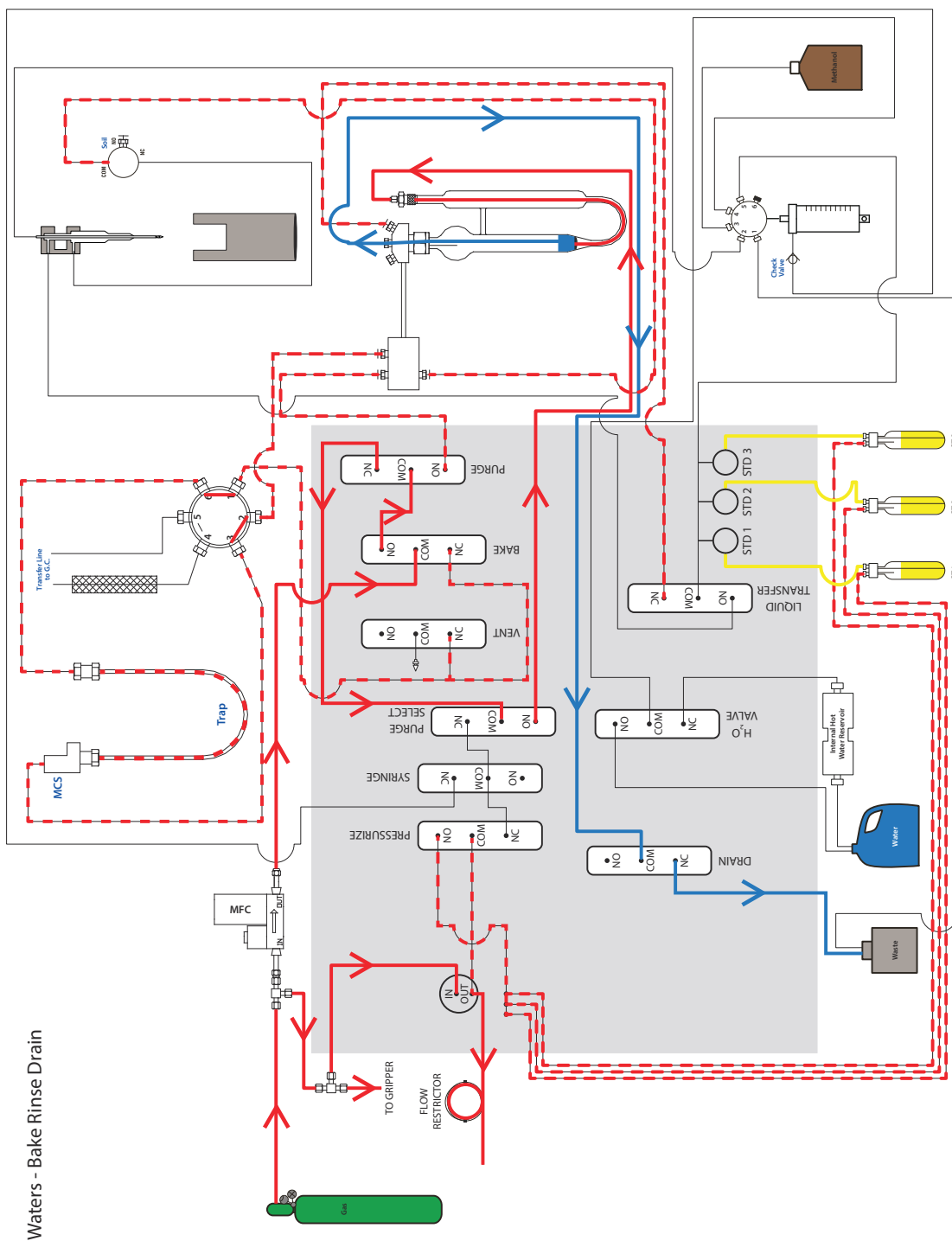

Figure A-13 Atomx XYZ - Waters Flow Diagram - Bake Rinse Drain

A.4.11 Atomx XYZ Waters Flow Diagram - Bake

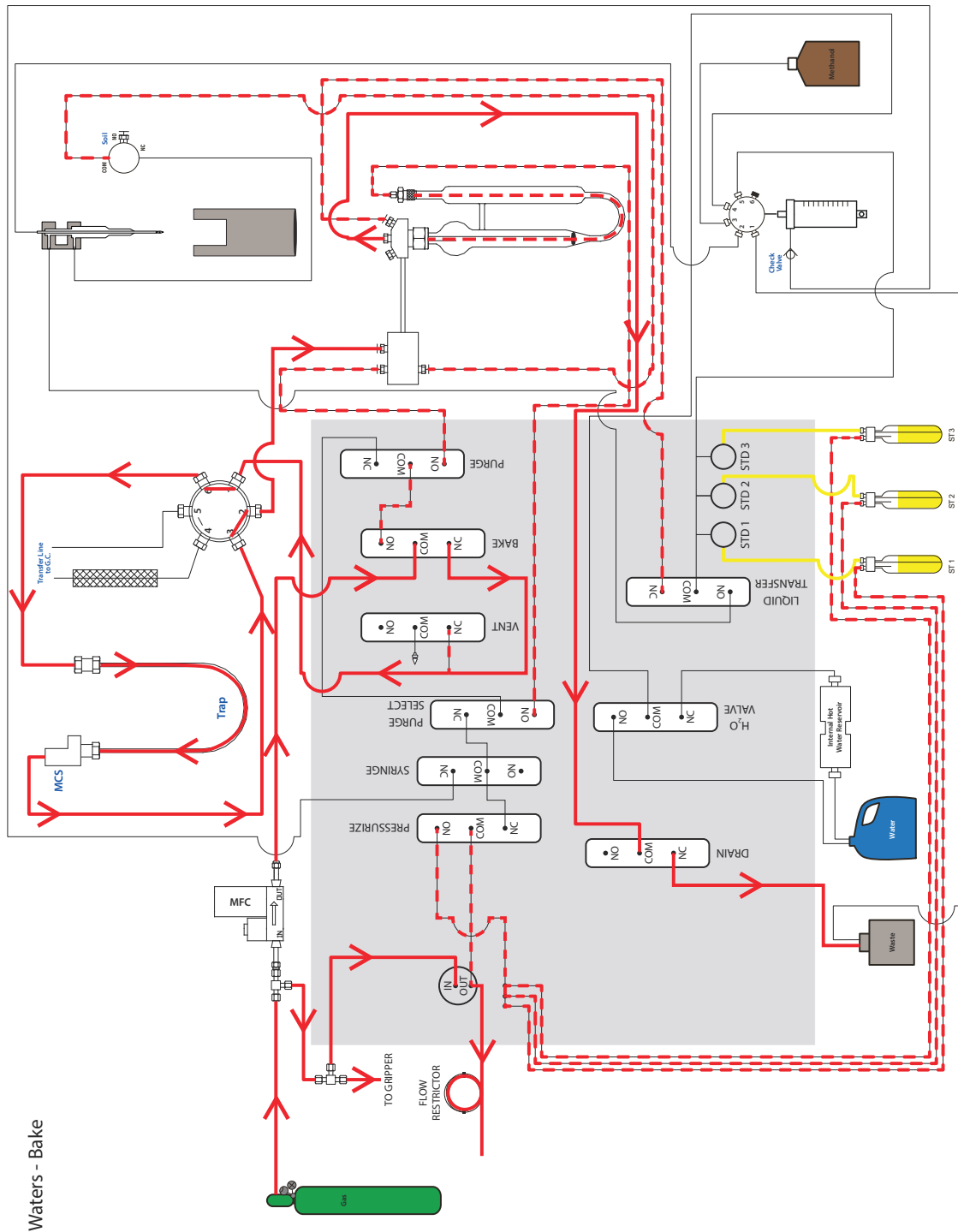

Figure A-14 Atomx XYZ - Waters Flow Diagram - Bake

**A.4.12 Atomx XYZ Soils Flow Diagram - Standby/Purge Ready**

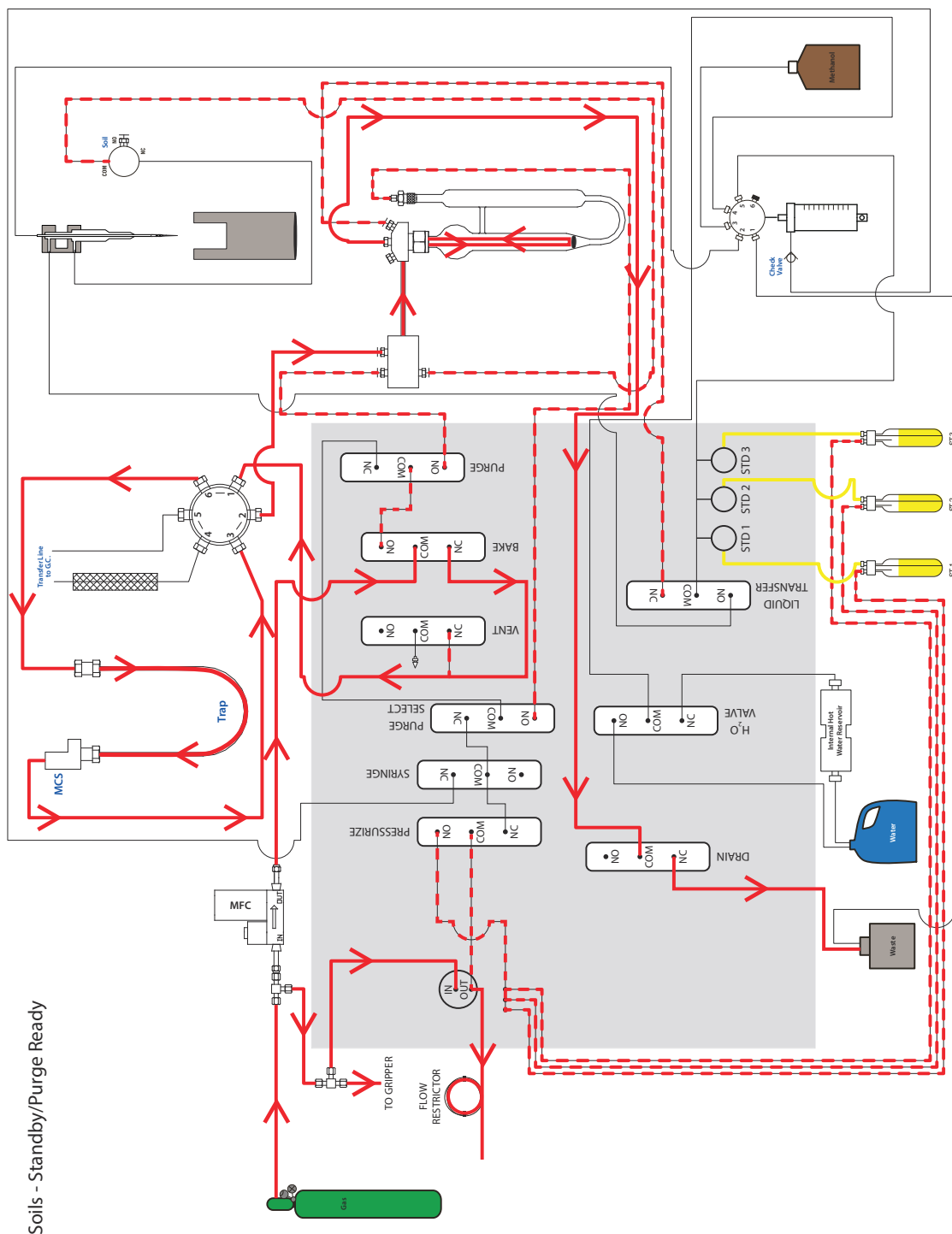

Figure A-15 Atomx XYZ - Soils Flow Diagram - Standby/Purge Ready



A.4.13 Atomx XYZ Soils Flow Diagram - DI Transfer to Vial

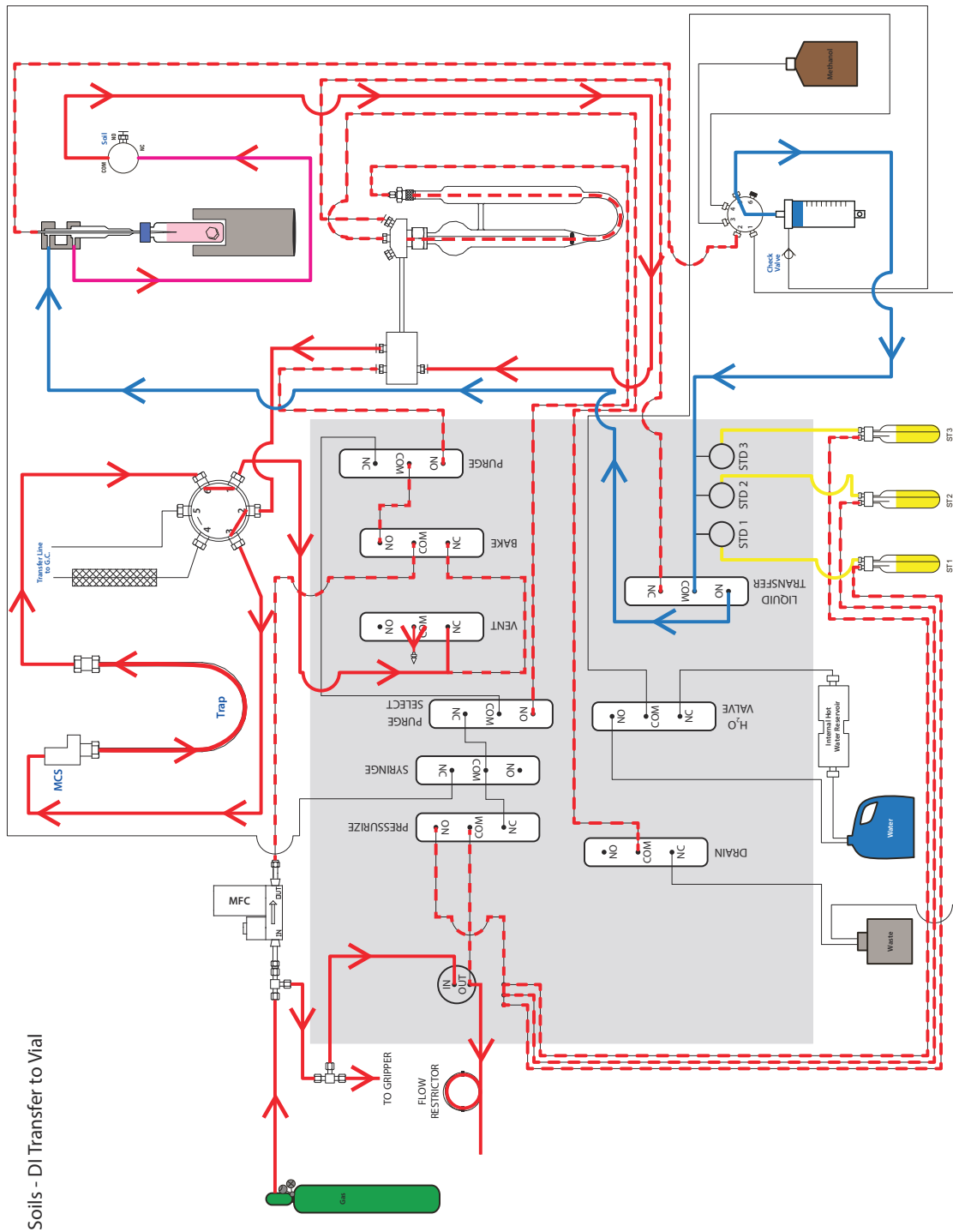
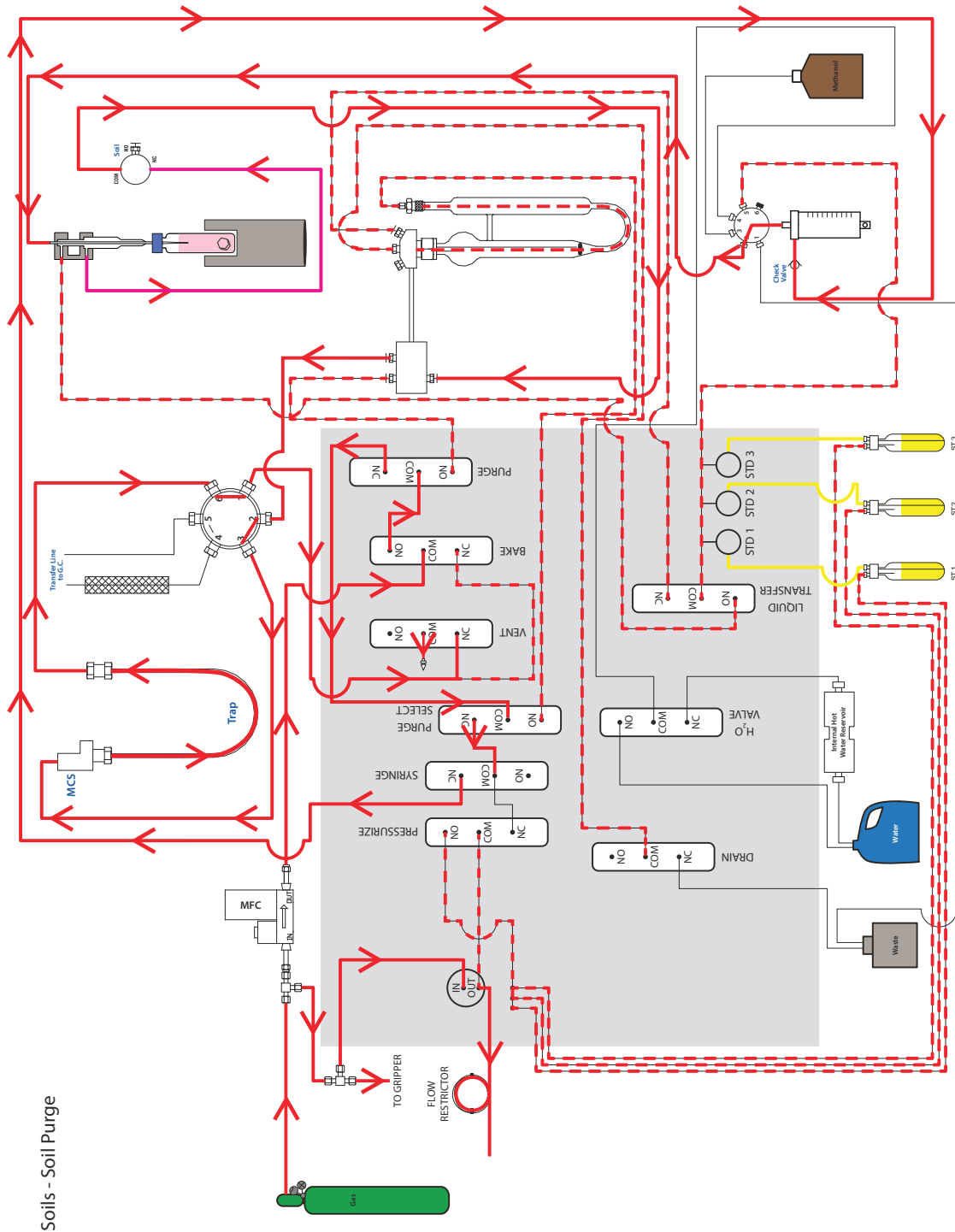

Figure A-16 Atomx XYZ - Soils Flow Diagram - DI Transfer to Vial

**A.4.14 Atomx XYZ Soils Flow Diagram - Purge**



Soils - Soil Purge

Figure A-17 Atomx XYZ - Soils Flow Diagram - Purge

A.4.15 Atomx XYZ Soils Flow Diagram - Dry Purge

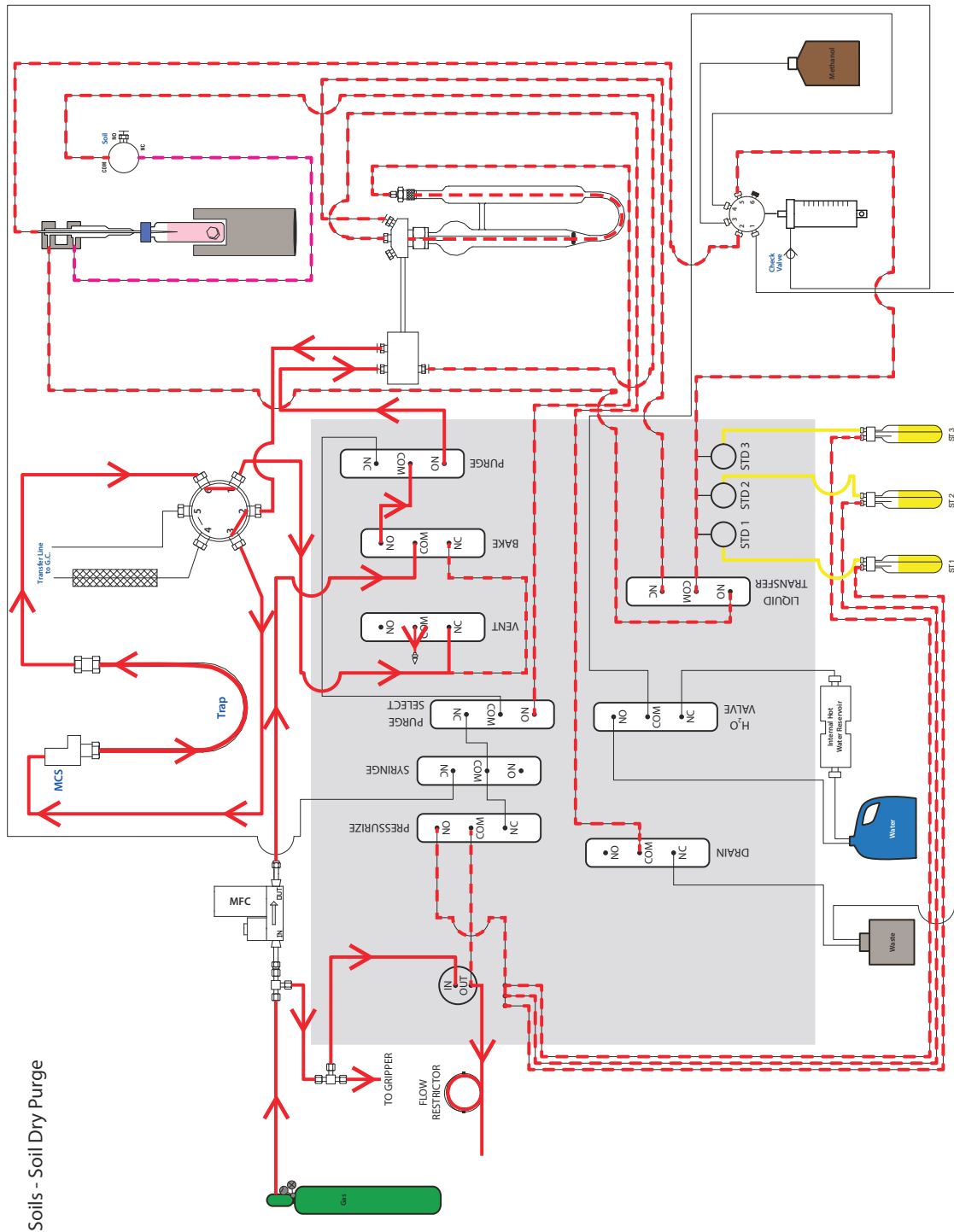

Figure A-18 Atomx XYZ - Soils Flow Diagram - Dry Purge

**A.4.16 Atomx XYZ Soils Flow Diagram - Bake**

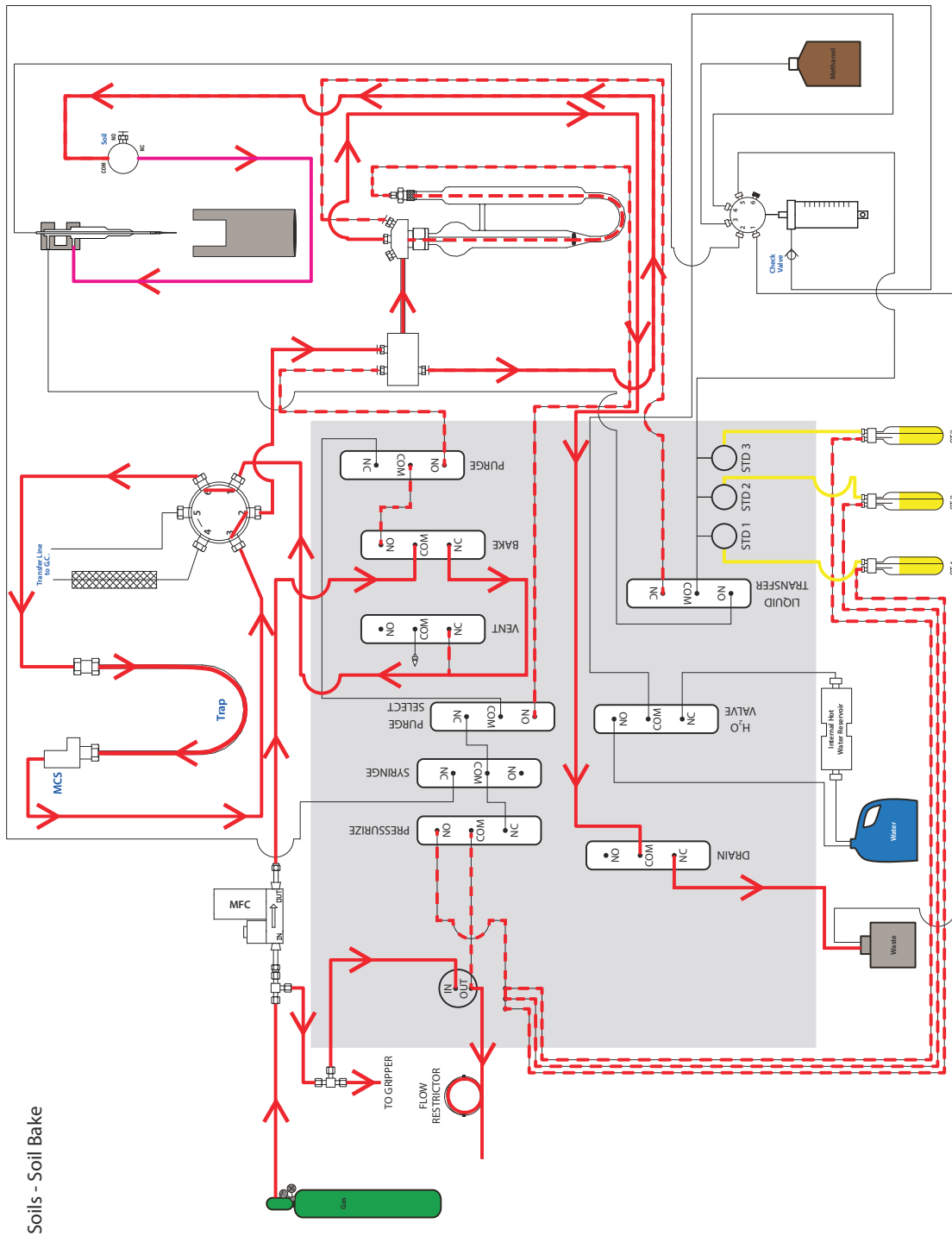

Figure A-19 Atomx XYZ - Soils Flow Diagram - Bake

A.4.17 Atomx XYZ Methanol Flow Diagram - Fill

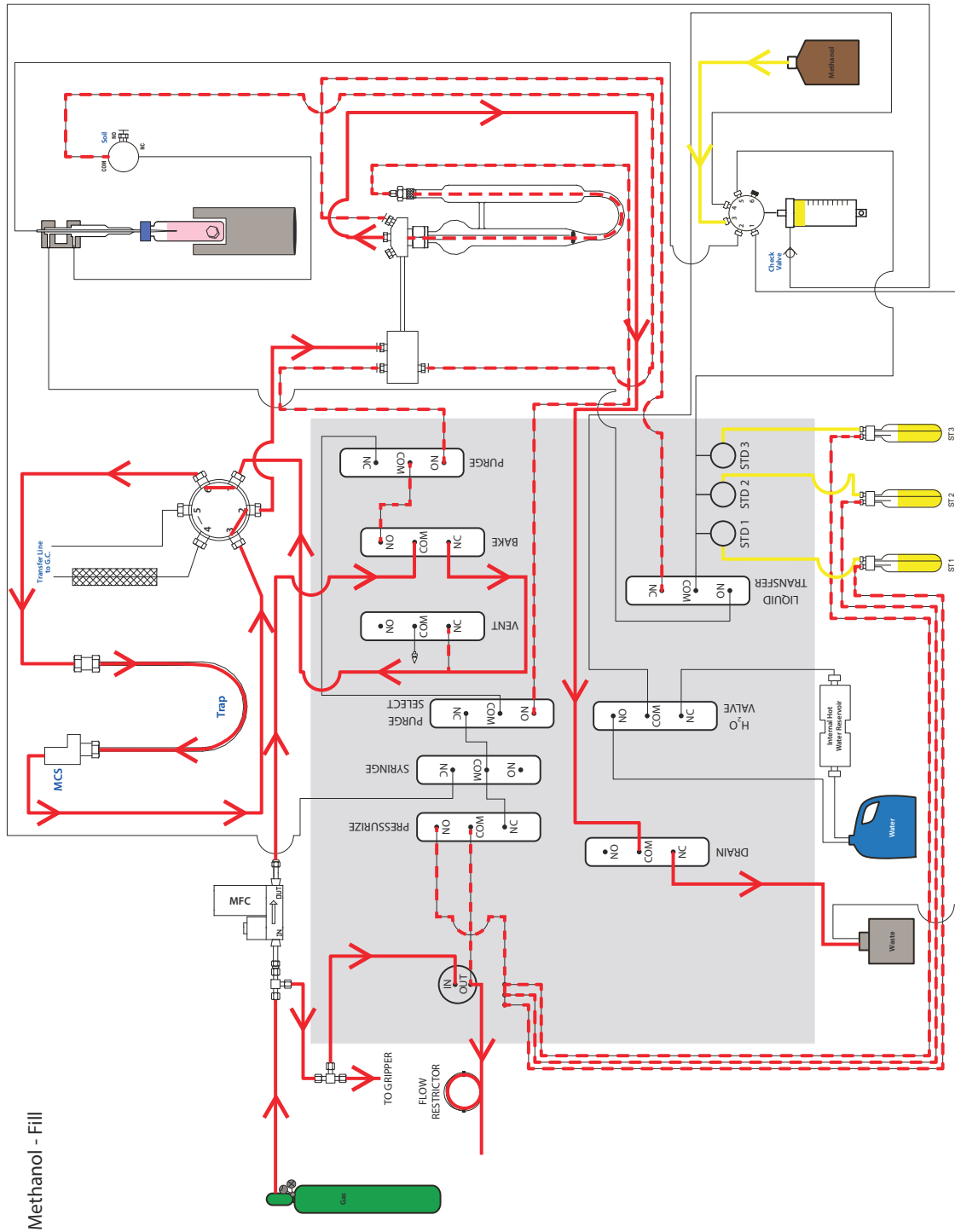

Figure A-20 Atomx XYZ - Methanol Flow Diagram - Fill

**A.4.18 Atomx XYZ Methanol Flow Diagram - Dispense to Vial**

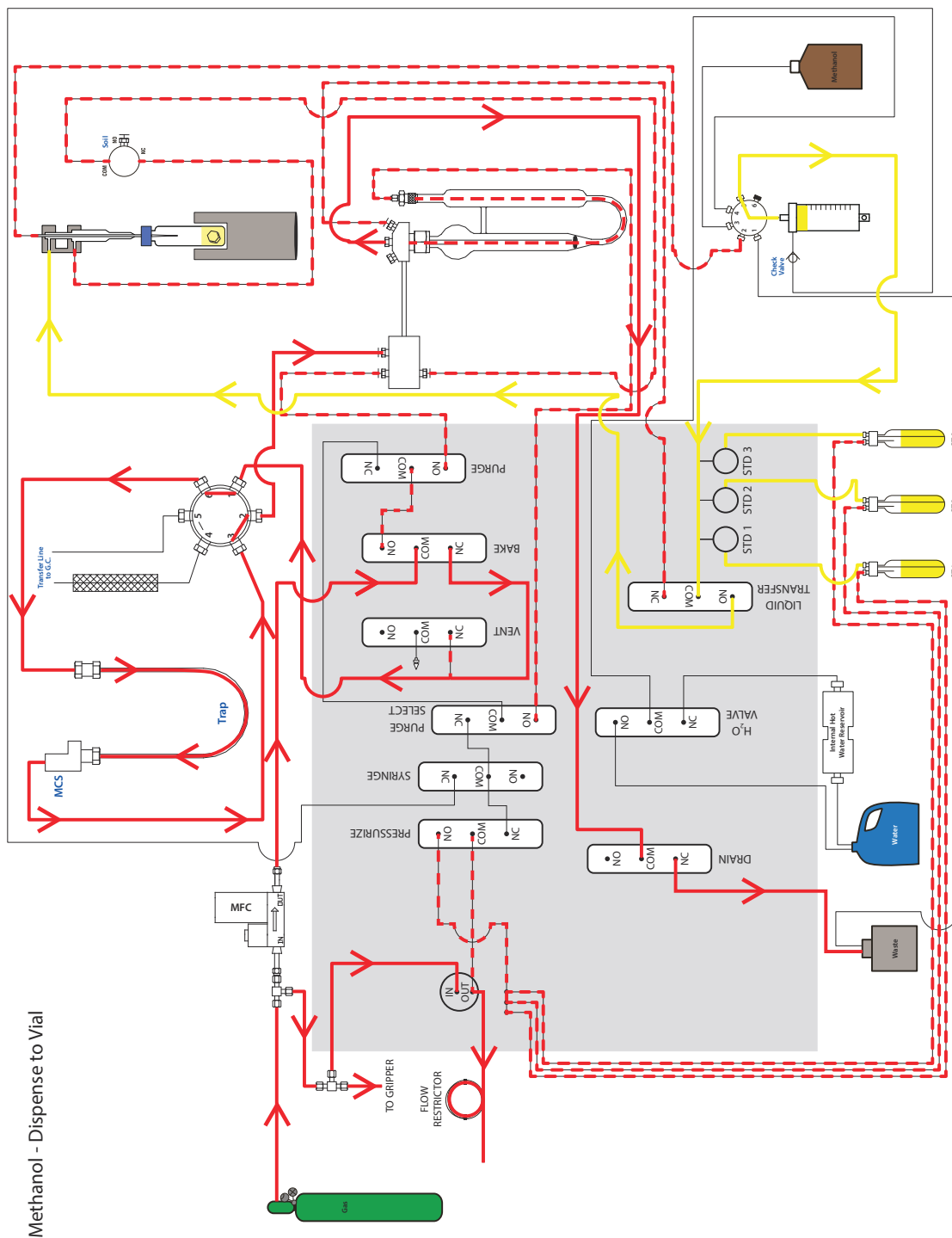

Figure A-21 Atomx XYZ - Methanol Flow Diagram - Dispense to Vial

A.4.19 Atomx XYZ Methanol Flow Diagram - Extract Fill

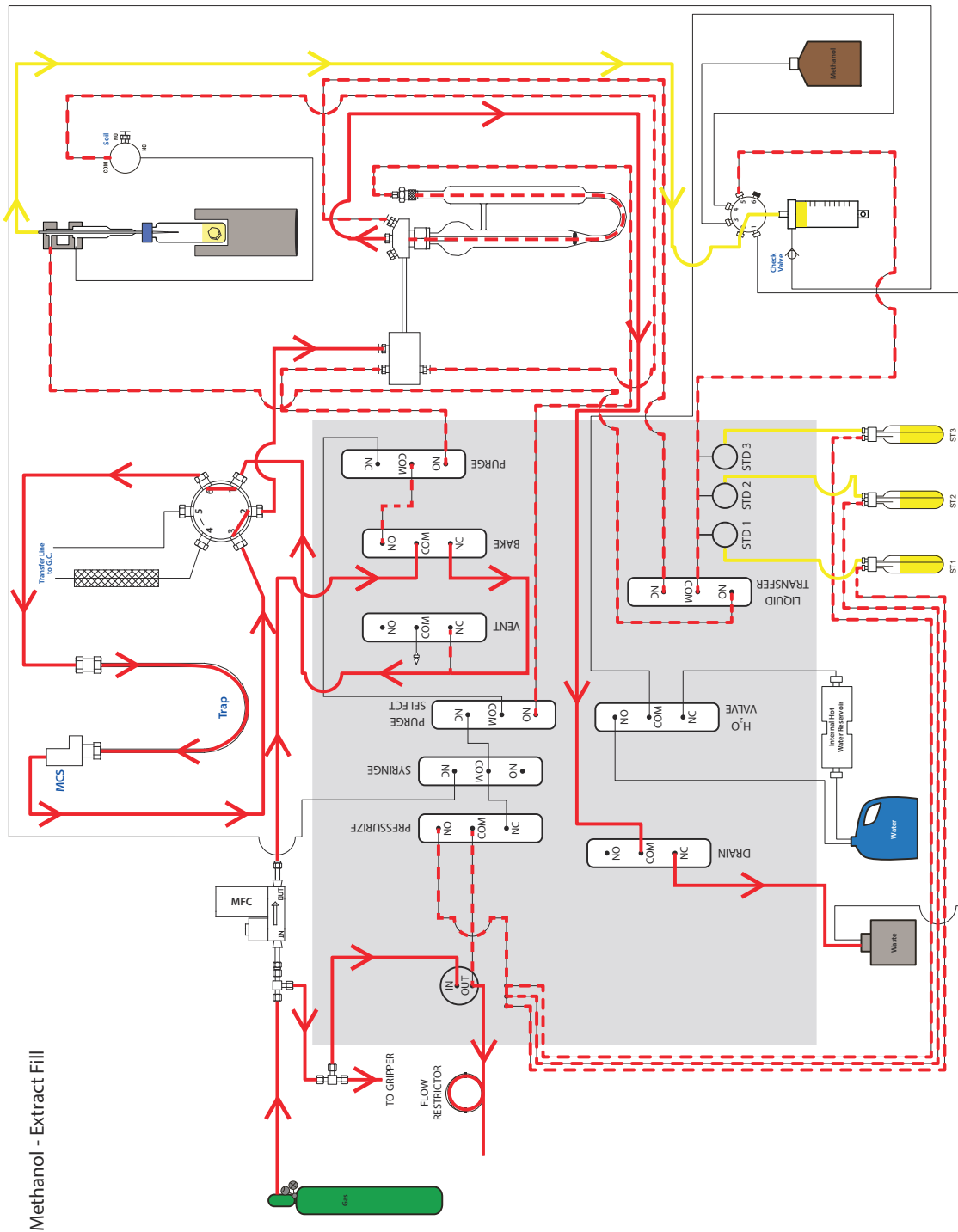

Figure A-22 Atomx XYZ - Methanol Flow Diagram - Extract Fill



**A.4.20 Atomx XYZ Methanol Flow Diagram - Dispense Extract to Glassware**

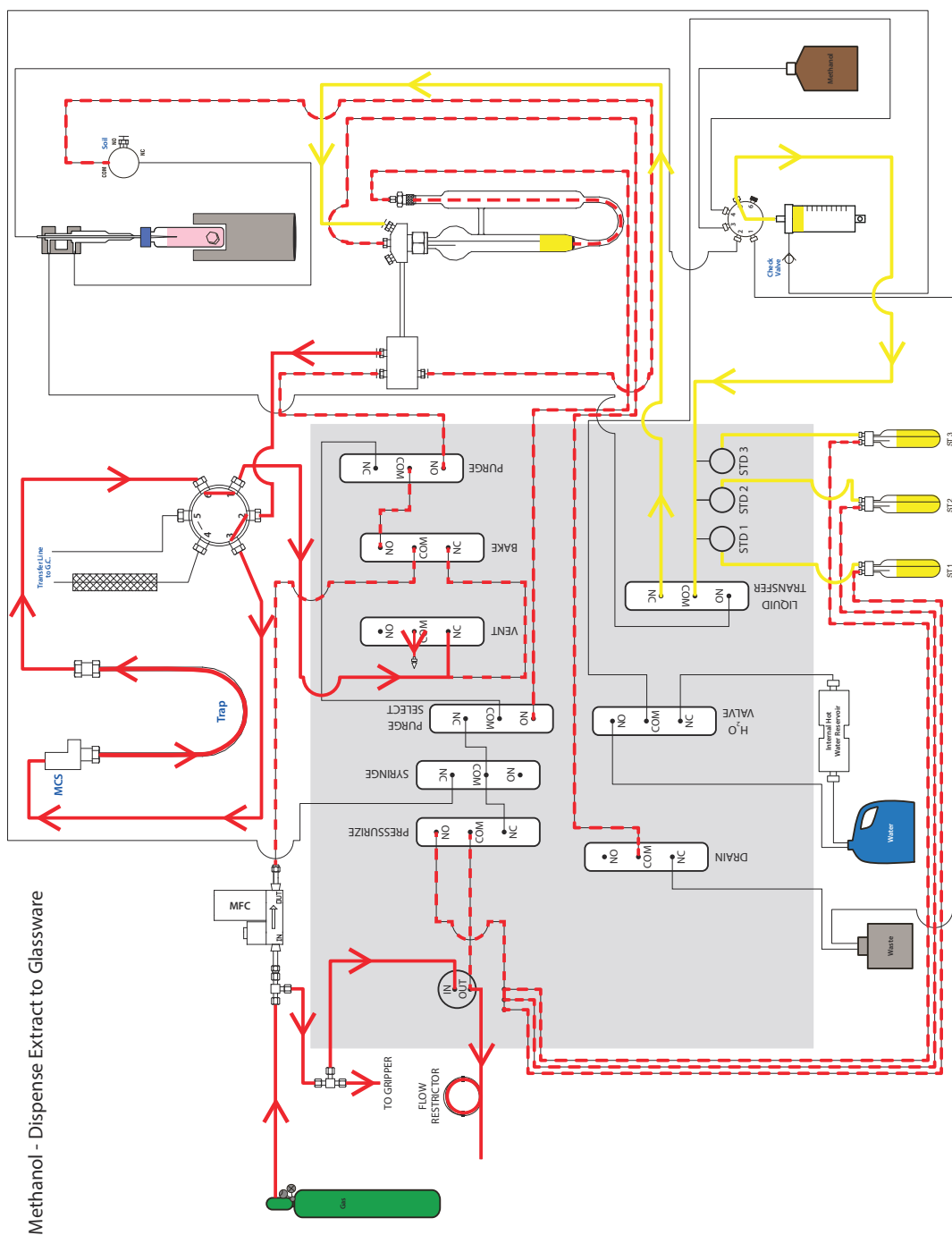

Figure A-23 Atomx XYZ - Methanol Flow Diagram - Dispense Extract to Glassware

A.4.21 Atomx XYZ - Eliminator Flow Diagram - Basic

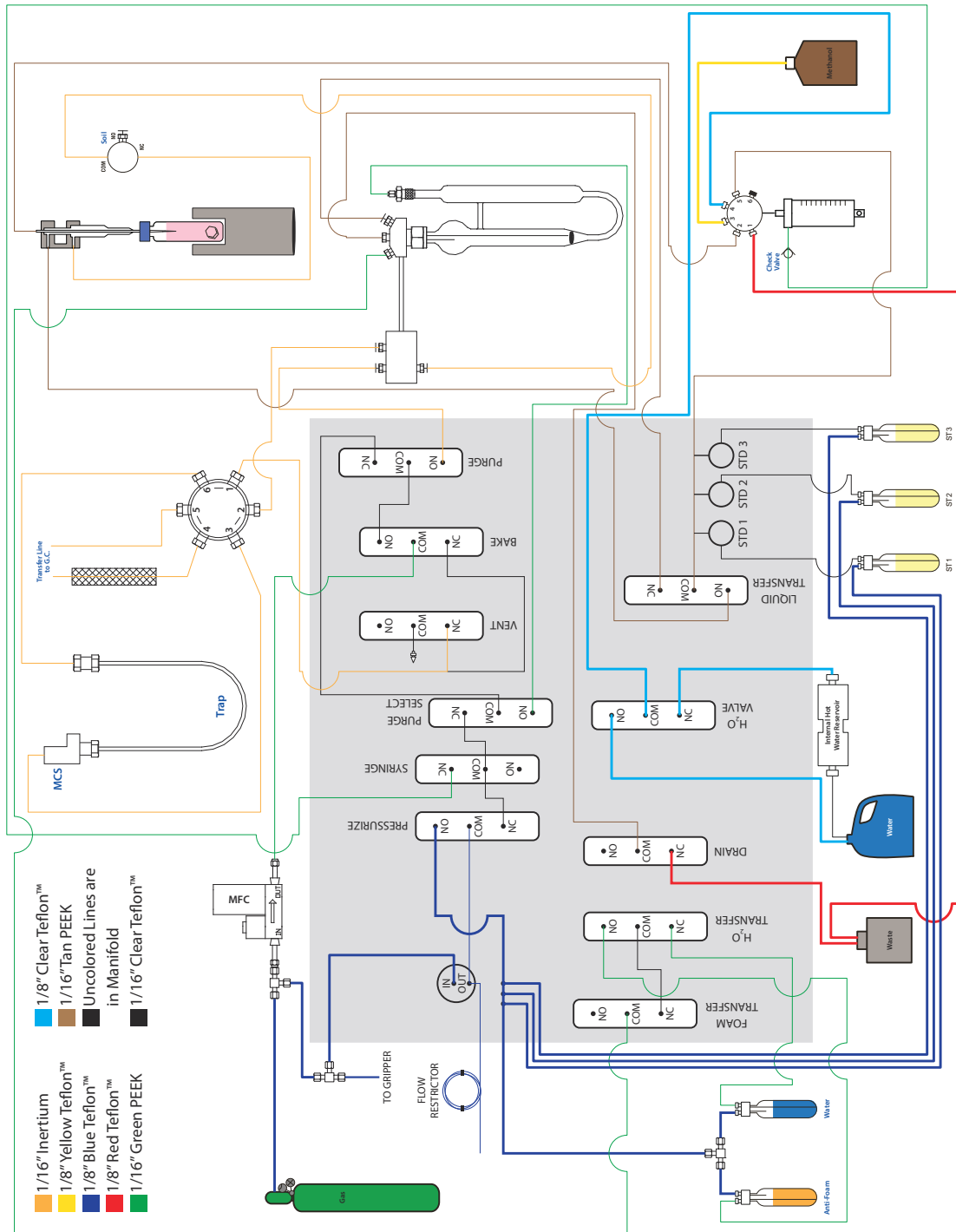

Figure A-24 Atomx XYZ - Eliminator Flow Diagram - Basic

**A.4.22 Atomx XYZ - Eliminator - Ready**

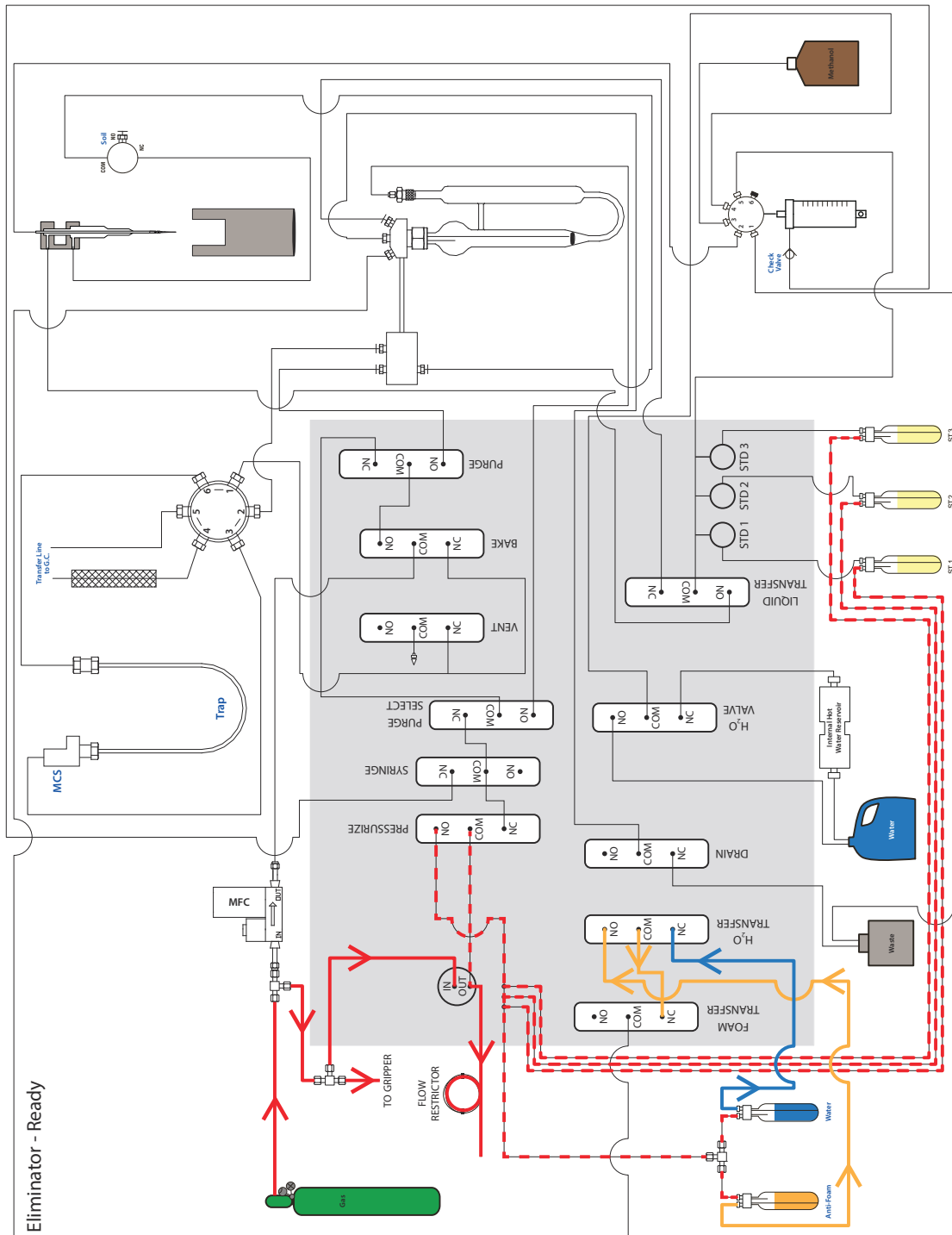

Figure A-25 Atomx XYZ - Eliminator Flow Diagram - Ready

A.4.23 Atomx XYZ - Eliminator Flow Diagram - Add Defoamer

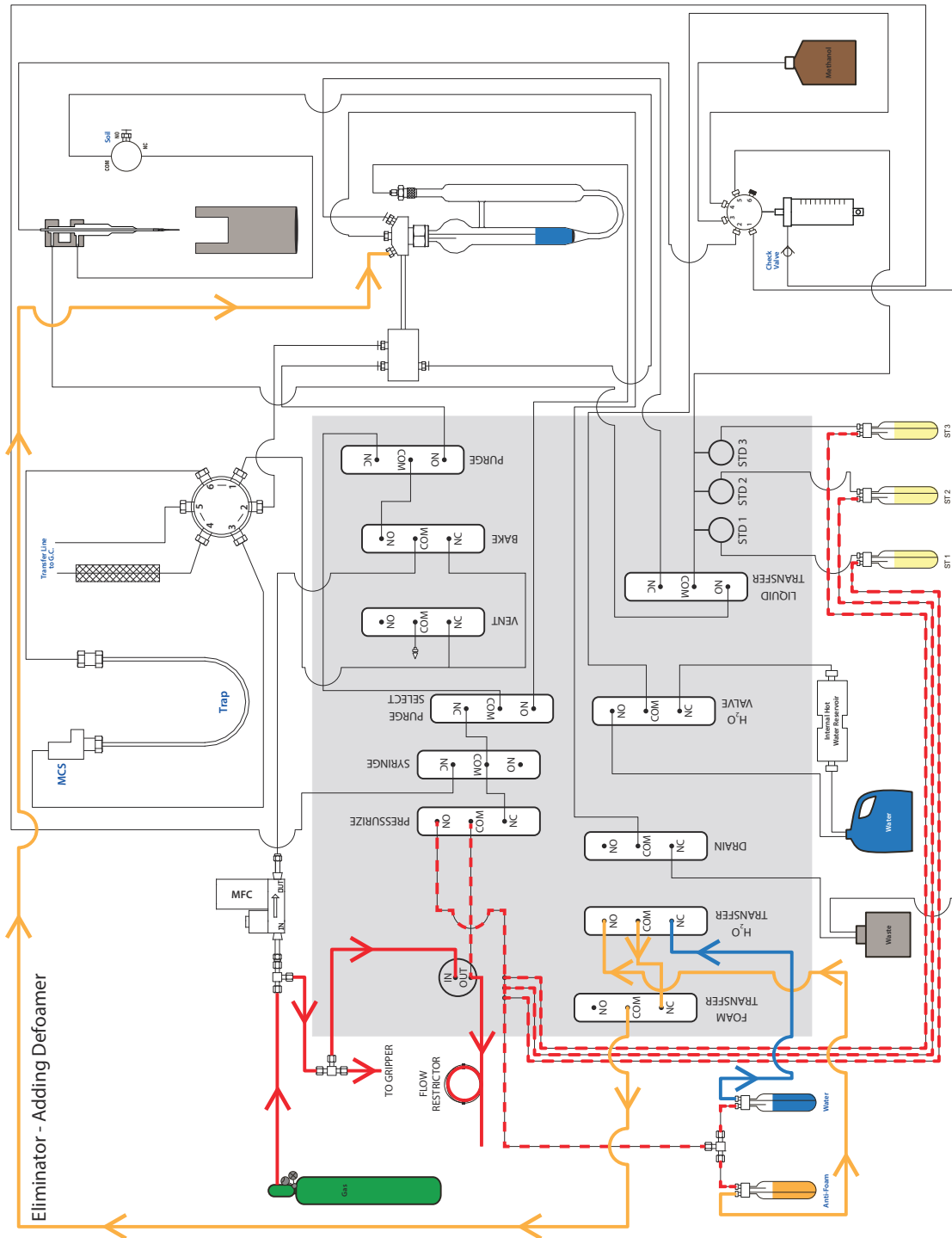

Figure A-26 Atomx XYZ - Eliminator Flow Diagram - Add Defoamer

**A.4.24 Atomx XYZ - Eliminator Flow Diagram - Rinse**

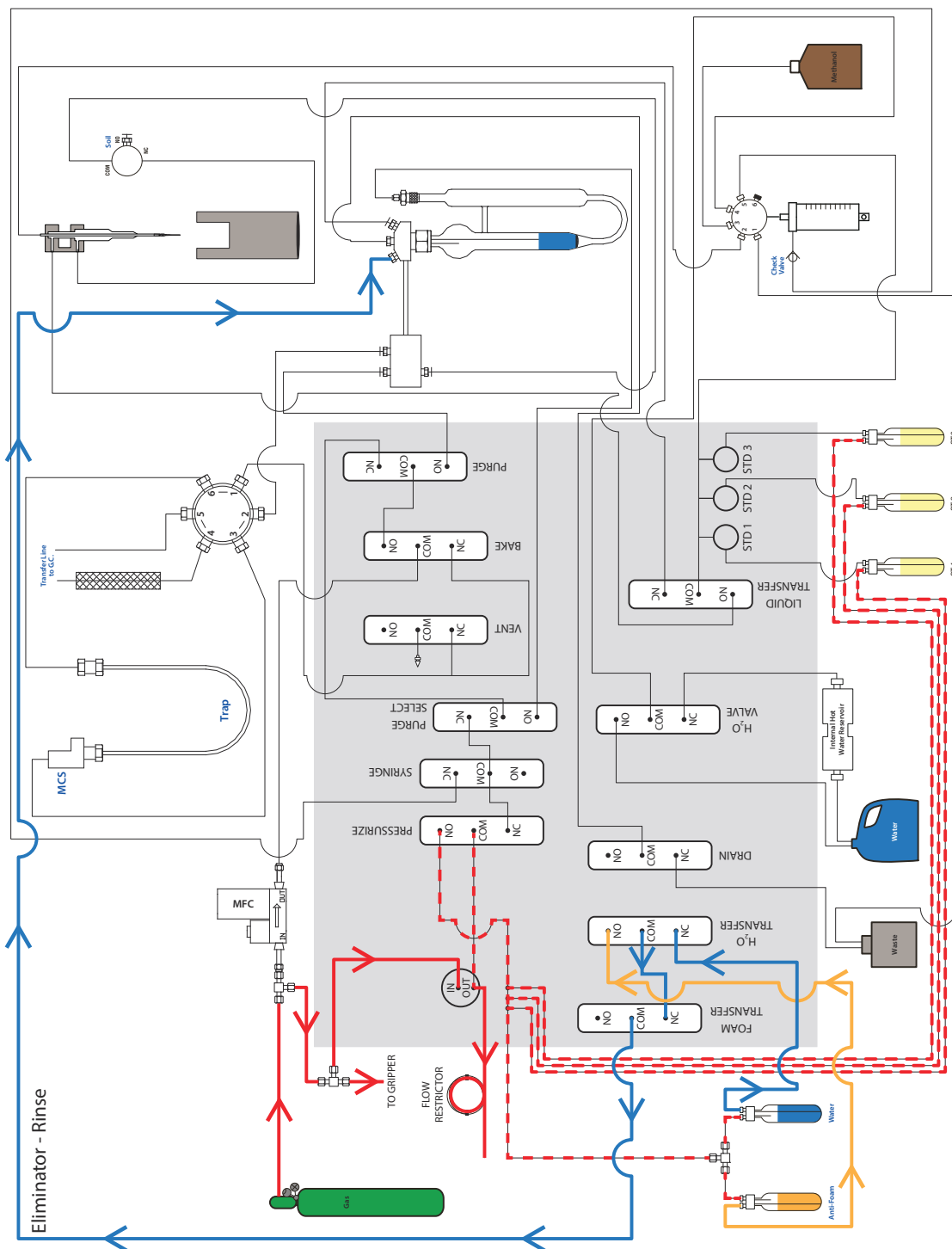

Figure A-27 Atomx XYZ - Eliminator Flow Diagram - Rinse

# Atomx XYZ User Manual

## Index

### Numerics

- 24VDC Power Supply, 5-18
- 5VDC Power Supply, 5-19
- 6-Port Syringe Valve, 1-15, 1-23
  - Status and Manual Control, 3-30
- 6-Port Valve, 1-22
  - Manual Control, 3-28

### A

- Abort Schedule, 3-45
- Accessories, 1-10, 1-23
  - Guardian Foam Sensor and Eliminator, 1-24
  - Sparge Vessel Heater, 1-23
  - Vial Chiller Plate, 1-24
- Analytical Trap, 1-19
  - Conditioning, 5-36
    - Bake Settings, 3-18
  - Conditioning Temperatures and Times, 5-36
  - Recommended Operating Conditions, 4-15
  - Replacement, 5-34
- Applications, 1-6
- Archive
  - Delete at Next Archive, 3-4
  - Settings, 3-46
- Atomx XYZ
  - Accessories, 1-10
  - Analytical Trap, 1-19
    - Conditioning, 5-36
    - Recommended Operating Conditions, 4-15
  - Applications, 1-6
  - Autosampler, 1-16
  - Carrier Gas Inlet, 1-20
  - Certifications, 1-6
  - Component Overview, 1-11
  - Computer Requirements, 1-9, 2-4
  - Configuration, 3-20
  - Diagnostics, 1-10
  - Dimensions, 1-5
  - Electrical
    - Autosampler Schematic, A-2
    - Concentrator Schematic, A-1
    - Overview, 5-10
    - Requirements, 1-9, 2-2
  - Elevator Assembly, 1-16
  - Environmental Specifications, 1-5
  - Essential Instructions, P-1
  - Flow Diagrams
    - Leak Check, 5-20
    - Modes, A-5
  - Gas Requirements, 2-3
  - GC Communication, 1-9
  - General Specifications, 1-5
  - Guardian Foam Sensor and Foam Eliminator, 1-24
    - Configure, 2-25
  - Heated Sample Transfer Line, 1-20
  - Heaters and Temperatures, 1-10
  - High-level Sample Specifications, 1-7
  - Instrument Part Numbers, 1-5
  - Internal Standard Vessels, 1-14
  - Liquid Handling Specifications, 1-8
  - Liquid Sample Specifications, 1-7
  - Low-level Sample Specifications, 1-7
  - Mass Flow Controller (MFC), 1-18
  - Methods, 1-6
  - Mixer Assembly, 1-17
  - Mode Descriptions, 4-1
  - Moisture Control System (MCS), 1-19
  - Operating Environment, 2-1
  - Optimization/Method Development, 4-8
  - Optional Sparge Vessel Heater, 1-23
  - Optional Vial Chiller, 1-24
  - Overview, 2-6
  - Part Numbers, 1-5
  - Performance Specifications, 1-6
  - Plumbing
    - Diagram, A-3
    - Overview, 5-8
  - Power Supply, 5-18
  - Pre-Installation, 2-1
  - Printed Circuit Boards, 5-10
  - Return Procedure, 5-66
  - Safety Labels, P-5
  - Safety Symbols Defined, P-3
  - Sample Injection Specifications, 1-8
  - Sample Mount and Sparger, 1-13
  - Sample Needle, 1-15
  - Sample Pathway, 1-18
  - Sample Purge Gas Inlet, 1-18
  - Sample Purge Gas Requirements, 1-8
  - Sample Specifications, 1-6
  - Specifications, 1-5
  - Standard Pressure Regulator, 1-14
  - Status Light, 1-17
  - System Control specifications, 1-9
  - Systems Test, 1-10
  - Troubleshooting, 5-60
  - Unit and Parts Disposal, 5-66
  - Valves
    - Output/Mechanisms Chart, 4-3
    - Overview, 1-21
    - Specifications, 1-9

- Vials, 1-13
  - Warranty, P-1
  - Work Surface Requirements, 2-2
  - Working Safely, P-6
  - Atomx XYZ TekLink, 3-1
    - Abort, Hold and Step Buttons, 3-3
    - About, 3-27
    - Archive Settings, 3-46
    - Bake Mode, 3-18
    - Bake Tab, 3-13
    - Benchmark Test, 3-31
    - Configuration, 3-20
    - Configure Gas Chromatograph, 3-21
    - Configure Guardian Foam Sensor, 3-21
    - Data Storage Settings, 3-46
    - Delete at Next Archive, 3-4
    - Desorb Mode, 3-19
    - Desorb Tab, 3-12
    - Diagnostics, 3-28
    - History Log, 3-25
    - Home Screen, 3-5
    - Instrument Control Buttons, 3-3
    - Instrument Manager, 3-23
    - Instrument Profile
      - Create, Connect and Deactivate, 3-32
    - Instrument Status Panel, 3-6
    - Leak Check, 3-17, 5-19
    - Manual Overrides, 3-28
    - Method
      - Creating, 3-36
      - Loading, 3-39
      - Opening, 3-36
      - Printing, 3-39
    - Method Type Selection, 3-35
    - Methods Screen, 3-7
    - Open, Save, Load, and Print Buttons, 3-3
    - Options, 3-21
    - Pinning Screens, 3-2
    - Primary Screens, 3-5
    - Prime, 3-17
    - Purge Tab, 3-8
    - Schedule
      - Creating, 3-39
      - Opening, 3-39
    - Schedules Screen, 3-14
    - Standby Tab, 3-7
    - System Properties, 3-23
    - Title Bar Information, 3-2
    - Tools Screen, 3-16
    - Touchscreen Capability, 3-1
    - Upgrade Firmware, 3-30, 5-59
    - Upgrade Software, 5-60
    - User Interface Overview, 3-1
    - Using Default Methods, 3-35
    - Valves and Flows, 3-28
    - Version, 3-27
  - Automation Specifications, 1-6
  - Autosampler, 1-16
    - Alignment, 5-38
    - Manual Movement, 3-29
  - Troubleshooting, 5-38
- B**
- Bake, 3-13, 4-11
  - Bake Rinse, 3-18
  - Bake Tab, 3-13
  - Banner Board, 5-16
  - Benchmark Test, 3-31, 5-60
  - Blank
    - Adding to Schedule, 3-40
- C**
- Carryover
    - Carryover Contamination Flow Chart, 5-65
  - Certifications, 1-6
  - Chilling, 1-24
  - Communication
    - Connection to Gas Chromatograph, 2-9
  - Components, 1-11
  - Computer Requirements, 1-9, 2-4
  - Conditioning Analytical Trap, 5-36
  - Connect to Instrument Profile, 3-23
  - CPU Communication Board (Master Board), 5-12
  - Customer Support, P-1, 5-66
- D**
- Data
    - Connections, 2-8
    - Storage Location, 3-46
    - USB Interface Cable, 2-22
  - DC Valve Control Board, 5-14
  - Desorb, 3-12, 4-11
    - Pre-Heat, 4-10
    - Ready, 4-10
    - Tab, 3-12
  - DI Water
    - Preparing, 2-27
    - Prime, 3-17
    - Reservoir, 2-13
    - Rinse, 3-18
  - Diagnostics, 1-10
  - Diagrams
    - Autosampler Electrical, A-2
    - Concentrator Electrical, A-1
    - Flow, A-1
    - Plumbing, A-3
  - Dimensions, 1-5
  - Disposal
    - of Parts, 5-66
    - of the Instrument, 5-66
  - Drain Line
    - Installation, 2-13
  - Dry Purge, 4-10
- E**
- Electrical
    - 24VDC Power Supply, 5-18
    - 5VDC Power Supply, 5-19



- Autosampler Schematic, A-2
- Concentrator Schematic, A-1
- Connections, 2-8
- Overview, 5-10
- Printed Circuit Boards (PCB), 5-10
- Requirements, 1-9, 2-2
- Troubleshooting
  - No Power Flow Chart, 5-62
- Elevator, 5-37
  - Assembly Overview, 1-16
  - Drive Board, 5-18
  - Manual Movement, 3-29
- Environmental Specifications, 1-5
- Ethanol, 4-8

## F

- Fans
  - Manual Control, 3-28
- Firmware
  - Upgrade, 3-30, 5-59
- Flavor and Fragrance, 4-8, 4-9
- Flavor and Fragrance Analysis, 3-9
- Flow Diagrams, A-1
  - Basic, A-5
  - Eliminator
    - Add Defoamer, A-27
    - Basic, A-25
    - Ready, A-26
    - Rinse, A-28
  - Leak Check
    - General, 5-20
    - Subsystem A, 5-22
    - Subsystem B, 5-24
    - Subsystem C, 5-26
  - Methanol
    - Dispense Extract to Glassware, A-24
    - Dispense to Vial, A-22
    - Extract Fill, A-23
    - Fill, A-21
  - Soils
    - Bake, A-20
    - DI Transfer to Vial, A-17
    - Dry Purge, A-19
    - Purge, A-18
    - Standby/Purge Ready, A-16
  - Waters
    - Bake, A-15
    - Bake Rinse Drain, A-14
    - Bake Rinse Fill, A-12
    - Bake Rinse Transfer, A-13
    - Desorb, A-11
    - Dry Purge, A-10
    - Purge, A-9
    - Sample Fill, A-7
    - Sample Transfer, A-8
    - Standby Purge Ready, A-6
- Fuse
  - Multi-Channel Temperature Control Board Replacement, 5-55

- PEM Replacement, 5-52

## G

- Gas
  - Carrier Gas Connection, 2-11
  - Connections, 2-10
  - Inlet, 1-18
  - Purge Gas Connection, 2-10
  - Purge Gas Settings, 3-21
  - Requirements, 1-8, 2-3
- Gas Chromatograph
  - Carrier Gas Connection to Atomx XYZ, 2-11
  - Carrier Gas Inlet, 1-20
  - Communication, 1-9
  - Configure Type, 3-21
  - GC I/O Cable and GC Type Reference, 5-5
  - GC I/O Connection to Atomx XYZ, 2-9
  - Heated Sample Transfer Line, 1-20
  - Heated Sample Transfer Line Installation, 2-11
  - Type
    - 31, 3-21
    - 63, 3-21
- Glassware
  - Cleaning Procedures, 5-27
- Gripper
  - Manual Movement, 3-29
  - Troubleshooting, 5-38
- Guardian Foam Sensor and Foam Eliminator, 1-24, 2-25
  - Enable/Disable, 3-21

## H

- Heated Zones, 1-10
- Helium
  - As Sample Purge Gas, 1-18
  - Grade Required, 1-8
  - Purge Gas Setting, 3-21
- High Polarity Compounds, 4-8
- History Log, 3-25
- Home Screen, 3-5

## I

- Installation
  - Carrier Gas Supply Connection, 2-11
  - Create Instrument Profile, 2-22
  - Drain Line, 2-13
  - Electrical and Data Connections, 2-8
  - Gas Connections, 2-10
  - GC I/O Cable, 5-5
  - GC I/O Connection to Gas Chromatograph, 2-9
  - Guardian Foam Sensor and Foam Eliminator, 2-25
  - Heated Sample Transfer Line Installation, 2-11
  - Kit Box, 2-5
  - Power Cord, 2-8
  - Pre-Installation, 2-1
  - Purge Gas Connection, 2-10
  - Required Tools and Supplies, 2-4
  - Unpacking, 2-5
  - USB Interface Cable, 2-22

- Installation Kit Box
    - Contents, 2-5
  - Instrument Access Panels, 5-6
  - Instrument Manager, 3-23
  - Instrument Part Number, 1-5
  - Instrument Profile, 3-20
    - Connect, 3-23
    - Create Profile, 3-23
    - Create, Connect and Deactivate, 3-32
    - Deactivate, 3-23
    - Properties, 3-23
  - Instrument Status Panel, 3-6
  - Internal Standard
    - Pressure, 3-19
    - Valve Control Board, 5-15
- L**
- Leak Check
    - Configuration and Settings, 3-22
    - Flow Diagrams, 5-19
    - Performing, 5-19
    - TekLink Controls, 3-17
  - Load Schedule, 3-43
- M**
- Maintenance
    - Analytical Trap
      - Conditioning, 5-36
      - Replacement, 5-34
    - Autosampler Electrical Schematic, A-2
    - Concentrator Electrical Schematic, A-1
    - Daily Maintenance Checks, 5-2
    - Electrical Overview, 5-10
    - Elevator Lubrication, 5-37
    - Glassware Cleaning, 5-27
    - Instrument Access Panels, 5-6
    - Internal Standard Vessel Pressure
      - Verifying and Setting, 5-28
    - Leak Check, 5-19
    - Monthly Maintenance Checks, 5-2, 5-3
    - Multi-Channel Temperature Control PCB
      - Fuse Replacement, 5-55
    - Plumbing Diagram, A-3
    - Plumbing Overview, 5-8
    - Power Entry Module Fuse Replacement, 5-52
    - Preventative Maintenance
      - Chart, 5-4
      - Checks, 5-2
    - Quarterly Maintenance Checks, 5-3
    - Replacing Parts, 5-1
    - Sample Needle Replacement, 5-30
    - Sparger Cleaning, 5-27
    - Sparger Replacement, 5-32
    - Syringe Initialization, 5-52
    - Syringe Replacement, 5-52
    - Weekly Maintenance Checks, 5-2
    - XYZ Autosampler Alignment, 5-38
  - Mass Flow Controller (MFC), 1-18
    - Current Flow Rate, 3-28
    - Manual Control, 3-28
  - Methanol
    - Prime, 3-17
    - Recommended Grade, 2-27
    - Reservoir, 2-14
    - Rinse, 3-18
    - Rinse Settings, 3-13
    - Rinse Volume, 3-13
  - Methanol Extraction
    - Method Parameters, 4-14
    - Valve Output/Mechanism Chart, 4-6
  - Method
    - Bake
      - Optimization, 4-11
    - Creating a, 3-36
    - Default Methods, 3-35
    - Desorb
      - Optimization, 4-11
    - Desorb Pre-Heat
      - Optimization, 4-10
    - Desorb Ready
      - Optimization, 4-10
    - Development/Optimization, 4-8
    - Dry Purge
      - Optimization, 4-10
    - List of Official Methods, 1-6
    - Loading, 3-39
    - Method Development, 4-8
    - Opening, 3-36
    - Parameters by Sample Type, 4-12
    - Pre-Purge
      - Optimization, 4-9
    - Printing, 3-39
    - Purge
      - Optimization, 4-10
    - Purge Ready
      - Optimization, 4-8
    - Sample Pre-Heat Time, 4-9
    - Sample Temperature, 4-9
    - Screen, 3-7
    - Standby
      - Optimization, 4-8
    - Temperature Optimization, 4-8
    - Type, 3-35
  - Method Parameters
    - Bake, 3-13
    - Desorb, 3-12
    - Methanol Extraction, 4-14
    - Purge, 3-8
    - Soil, 4-13
    - Standby, 3-7
    - Waters, 4-12
  - Mixer Assembly, 1-17
  - Modes
    - Bake, 4-11
    - Descriptions, 4-1
    - Desorb, 4-11
    - Desorb Pre-Heat, 4-10
    - Desorb Ready, 4-10
    - Dry Purge, 4-10

- Flow Diagrams, A-5
- Pre-Heat, 4-9
- Pre-Purge, 4-9
- Purge, 4-10
- Purge Ready, 4-8
- Standby, 4-8
- Step to Next, 3-44
- Moisture Control System (MCS), 1-19

## N

- Nitrogen
  - As Sample Purge Gas, 1-18
  - Grade Required, 1-8
  - Purge Gas Setting, 3-21
- Notations and Hazard Severity Levels, P-2

## O

- Optimization
  - Bake, 4-11
  - Desorb, 4-11
  - Desorb Pre-Heat, 4-10
  - Desorb Ready, 4-10
  - Dry Purge, 4-10
  - Pre-Heat
    - Temperature and Pre-Heat Time, 4-9
  - Pre-Purge
    - Optimization, 4-9
  - Purge, 4-10
  - Purge Ready, 4-8
  - Sample Temperature, 4-9
  - Standby
    - Flow, 4-8
    - Temperature, 4-8

## P

- Parameters
  - Methanol Extraction, 4-14
  - Optimization, 4-8
  - Recommended, 4-8
  - Soil, 4-13
  - Water, 4-12
- Performance Specifications, 1-6
- Plumbing
  - DI Water Reservoir, 2-13
  - Diagram, A-3
  - Methanol Reservoir, 2-14
  - Overview, 5-8
- Power Entry Module
  - Fuse Replacement, 5-52
- Power Supply, 5-18
- Pre-Installation, 2-1
- Pre-Purge, 4-9
- Pre-Purge Time, 4-9
- Preventative Maintenance
  - Daily Maintenance Checks, 5-2
  - Monthly Maintenance Checks, 5-2
  - Weekly Maintenance Checks, 5-2
- Printed Circuit Boards

- Banner Board, 5-16
- CPU Communication Board (Master Board), 5-12
- DC Valve Control Board, 5-14
- Elevator Drive Board, 5-18
- Internal Standard Valve Control Board, 5-15
- Multi-Channel Temperature Control Board, 5-13
  - Fuse Replacement, 5-55
- Overview, 5-10
- Upgrade Firmware, 3-30, 5-59
- XYZ Control Board, 5-17
- XYZ Input/Output Board, 5-17
- XYZ Interface Board, 5-16
- Purge, 3-8, 4-10
  - Gas Settings, 3-21
  - Recommended Flow Rate, 4-10
  - Volume, 4-10
- Purge and Trap
  - Background, 1-1
  - History, 1-2
  - Overview, 1-2
  - Trapping, Adsorption, Desorption, 1-4
- Purge Tab, 3-8

## R

- Replacement Parts, 5-1
- Replacing Parts, 5-1
- Returning the Atomx XYZ, 5-66
- Run Schedule, 3-43

## S

- Safety
  - Atomx XYZ
    - Safety Labeling, P-5
  - Essential Instructions, P-1
  - Notations and Hazard Severity Levels, P-2
  - Safety Symbols Defined, P-3
  - Working Safely, P-6
- Sample Glass, 1-23
- Sample Heater, 3-9, 4-9
- Sample Mount, 1-13
- Sample Needle, 1-15
  - Cleaning, 5-30
- Sample Pathway, 1-18
- Sample Pre-Heat Time
  - Optimization, 4-9
- Sample Purge Gas Inlet, 1-18
- Sample Specifications, 1-6
- Sample Temperature
  - Optimization, 4-9
- Schedule, 3-14
  - Abort Schedule, 3-45
  - Add Blank, 3-40
  - Add Lines, 3-40
  - Add Standard, 3-42
  - Adding a Blank, 3-40
  - Choose Method, 3-41
  - Creating a, 3-39
  - Dilutions, 3-42
  - Fill Up/Fill Down, 3-40

- Hold Schedule, 3-44
- Load Schedule, 3-43
- Opening, 3-39
- Print Schedule, 3-43
- Step Schedule, 3-44
- Use Check-box, 3-40
- Schedules Screen, 3-14
- Soil
  - Method Parameters, 4-13
  - Valve, 1-22
  - Valve Output/Mechanism Chart, 4-5
- Solenoid Valves, 1-21
- Sparger
  - Optional Heater, 1-23
  - Options, 1-13
  - Replacement, 5-32
  - Sample Heater Parameters, 3-9
  - Volumes and Pre-Purge, 4-9
- Specifications
  - General, 1-5
  - Heater Temperatures, 1-10
  - High-level Sample Specifications, 1-7
  - Liquid Handling, 1-8
  - Liquid Sample Specifications, 1-7
  - Low-level Sample Specifications, 1-7
  - Operating System and System Control, 1-9
  - Performance, 1-6
  - Sample Gas Handling, 1-8
  - Standard Injection, 1-8
  - Valves, 1-9
- Standards (Internal)
  - Manual Dispense, 3-29
  - Pressure Regulator, 1-14
  - Prime, 3-17
  - Verifying and Setting Vessel Pressure, 5-28
  - Vessels, 1-14
- Standards (Working)
  - Preparing, 2-28
- Standby, 3-7, 4-8
  - Flow to Prevent Contamination, 4-8
  - Optimization, 4-8
  - Tab, 3-7
- Status Light, 1-17, 5-16
- Step Control Button, 3-44
- Syringe, 1-15
  - Initialization, 5-52
  - Initialize, 3-30
  - Replacement, 5-52
  - Status and Manual Control, 3-30
- System
  - Control, 1-9
  - Overview, 2-6
  - Properties, 3-23
  - Tests, 1-10

**T**

- Technical Assistance, 5-66
- TekLink
  - See Atomx XYZ TekLink, 3-1

- Teledyne Tekmar
  - Contact Information, P-1
- Temperature, 4-8
  - Optimization, 4-8
- Temperature Control Board, 5-13
- Tools Screen, 3-16
- Trap, 1-19
  - Conditioning, 5-36
  - Recommended Operating Conditions, 4-15
  - Replacement, 5-34
- Troubleshooting, 5-60
  - 6-Port Syringe Valve, 3-30
  - Atomx XYZ TekLink Version Details, 3-27
  - Benchmark Test, 3-31, 5-60
  - Carryover Contamination Flow Chart, 5-65
  - Desorb Mode, 3-19
  - Diagnostics, 3-28
  - Flow Diagrams, A-1
  - Leak Check, 3-17
  - Leak Check Settings, 3-22
  - Low Response Flow Chart, 5-64
  - Manual Control of Valves and Flows, 3-28
  - No Power Flow Chart, 5-62
  - No Response Flow Chart, 5-63
  - Syringe, 3-30
  - Technical Assistance, 5-66
  - View History Log, 3-25

**U**

- Upgrade Firmware, 3-30, 5-59
- Upgrade Software, 5-60
- USB

- Interface Cable, 2-22

**V**

- Valves
  - Manual Control, 3-28
  - Output/Mechanism Chart, 4-3
  - Overview.Standards (Internal) Pressure Regulator, 1-21
  - Specifications, 1-9
- Vial Chiller, 1-24
- Vial Column
  - Add/Remove to Schedule, 3-21
- Vials, 1-13

**W**

- Warranty, P-1
- Waters
  - Method Parameters, 4-12
  - Valve Output/Mechanism Chart, 4-3

**X**

- XYZ Control Board, 5-17
- XYZ Input/Output Board, 5-17
- XYZ Interface Board, 5-16